

PFAFF

939 U

3704^{-2/02}_{-2/03}

Teileliste

Parts list

Liste de pièces

Lista de piezas

Diese Teileliste hat für Maschinen ab nachfolgender
Seriennummer Gültigkeit:

This parts list applies to machines from the following
serial numbers onwards:

Cette liste de pièces est valable pour les machines au
numéros de série à partir de:

Esta lista de piezas tiene validez para máquinas a partir del
número de serie siguiente:

2660862 →

Alle Informationen und Abbildungen waren zum Zeitpunkt der Druckgebung auf dem neusten Stand.

Technische Änderungen vorbehalten!

Der Nachdruck, die Vervielfältigung sowie die Übersetzung - auch auszugsweise - aus PFAFF-Teilelisten ist nur mit unserer vorherigen Zustimmung und mit der Quellenangabe gestattet.

At the time of printing, all information and illustrations contained in this document were up to date.

Subject to alteration!

The reprinting, copying or translation of PFAFF Parts lists whether in whole or in part, is only permitted with our previous permission and with written reference to the source.

Au moment de la remise à l'imprimeur, toutes les informations et figures se rapportant à cette machine correspondaient à l'état actuel des connaissances.

Sous réserve de modifications techniques!

Aucune reproduction, polycopie ou traduction - même par extraits - des listes de pièces PFAFF ne peut être effectuée, à condition d'en indiquer l'origine, sans notre autorisation expresse.

Todas las informaciones e ilustraciones de este manual estaban al día en el momento de entregarse para su impresión.

¡ Salvo modificaciones técnicas!

La reimpresión, reproducción y traducción - aunque sólo sea parcial - de las listas de piezas PFAFF sólo está permitida con nuestro permiso previo e indicando la fuente.

PFAFF Industrie Maschinen AG

Postfach 3020

D-67653 Kaiserslautern

Königstr. 154

D-67655 Kaiserslautern

Redaktion/Illustration

Verlag Technische Dokumentation

Postfach 1106

D-77901 Lahr

	Seite Page Page Página
0 Wichtiger Hinweis	0 - 1
Important note	
Avis important	
Observación importante	
1 Vorwort	1 - 1
Foreword	
Avant-propos	
Notas preliminares	
2 Erläuterungen der Schlüsselzeichen	2 - 1
Explanation of key markings	
Explication des symboles	
Explicaciones de los signos clave	
3 Basismaschine (PFAFF 939 U)	
Basic machine (PFAFF 939 U)	
Machine de base (PFAFF 939 U)	
Máquina básicas (PFAFF 939 U)	
3.01 Gehäuseteile	3 - 1
Housing sections	
Parties du corps	
Piezas del cárter	
3.02 Kopfteile	3 - 2
Needle head parts	
Pièces de tête	
Piezas de la cabeza	
3.03 Armteile	3 - 6
Arm parts	
Pièces de bras	
Piezas del brazo	
3.04 Grundplattenteile	3 - 15
Bedplate parts	
Pièces du plateau fondamental	
Piezas del cárter	
4 Fadenabschneid-Einrichtung (-900/24)	4 - 1
Thread trimmer (-900/24)	
Coupe-fil (-900/24)	
Cortahilos (-900/24)	

	Seite Page Page Página
5 Presserfuß-Automatik (-910/04)	5 - 1
Automatic presser foot lifter (-910/04)	
Relève-pied automatique (-910/04)	
Alzaprensatelas (-910/04)	
6 Verriegelungs-Einrichtung (-911/35)	6 - 1
Backtacking mechanism (-911/35)	
Dispositif à points d'arrêt (-911/35)	
Rematador (-911/35)	
7 Wartungseinheit (-925/03)	7 - 1
Air filter / lubricator (-925/03)	
Conditionneur d'air comprimé (-925/03)	
Grupo acondicionador del aire comprimido (-925/03)	
8 Elektrische Ausrüstung (PFAFF 939 U)	
Electrical equipment (PFAFF 939 U)	
Équipement électrique (PFAFF 939 U)	
Equipo eléctrico (PFAFF 939 U)	
8.01 Kabelbaum zum Oberteil	8 - 1
Cable tree to sewing head	
Faisceau de câbles vers la tête de machine	
Mazo de cables para el cabezal	
8.02 Tastschalter	8 - 2
Push-button	
Interrupteur à bouton-poussoir	
Interruptor pulsador	
8.03 Oberteilerkennung	8 - 2
Sewing head identification	
Detection de la tête	
Detección de la parte superior	
8.04 Bedienfeld	8 - 3
Control panel	
Panneau de commande	
Panel de mandos	
8.05 Einbaumotor	8 - 4
Built-in motor	
Moteur incorporé	
Motor incorporado	

	Seite Page Page Página
8.06 Sollwertgeber	8 - 6
Set-point generator	
Codeur	
Emisor del valor teórico	
8.07 Motor-Hauptschalter	8 - 7
Main switch	
Interrupteur général	
Interruptor principal	
8.08 Steuerkasten	8 - 8
Control box	
Boîte de contrôle	
Caja de mandos	
9 Garnrollenstände	9 - 1
Reel stands	
Porte-bobines	
Portacarretes	
10 Einstellehren	10 - 1
Adjustment gauges	
Calibres	
Calibres de ajuste	
11 Teile zur Tischplatte	10 - 1
Parts for table top	
Pièces du plateau	
Piezas para el tablero	
12 Knielüfterteile	12 - 1
Knee lifter parts	
Pièces du releveur de genouillère	
Piezas del alzaprensateles por rodillera	
13 Keilriemen	12 - 1
V-belt	
Courroie trapézoïdale	
Correa trapezoidal	
14 Schmiermittel-Übersicht	14 - 1
Overview of lubricants	
Tableau de lubrifiants	
Tabla de lubricantes	

	Seite Page Page Página
15 Basismaschine (PFAFF 3704) Basic machine (PFAFF 3704) Machine de base (PFAFF 3704) Máquina básicas (PFAFF 3704)	
15.01 Gehäuseteile	15 - 1
Housing sections Parties du corps Piezas del cárter	
15.02 Kopfteile	15 - 2
Needle head parts Pièces de tête Piezas de la cabeza	
15.03 Armteile	15 - 3
Arm parts Pièces de bras Piezas del brazo	
15.04 Grundplattenteile	15 - 7
Bedplate parts Pièces du plateau fondamental Piezas del cárter	
16 Pneumatische Ausrüstung	16 - 1
Pneumatic equipment Equipement pneumatique Equipo neumático	
17 Elektrische Ausrüstung (PFAFF 3704) Electrical equipment (PFAFF 3704) Equipement électrique (PFAFF 3704) Equipo eléctrico (PFAFF 3704)	
17.01 Kabelbaum zum Oberteil	17 - 1
Cable tree to sewing head Faisceau de câbles vers la tête de machine Mazo de cables para el cabezal	
17.02 Positionsgeber	17 - 2
Synchronizer Synchronisateur Sincronizador	

	Seite Page Page Página
17.03 Anbausatz für externen Motor	17 - 3
Mounting kit for external motor	
Jeu de pièces pour moteur externe	
Juego de piezas acoplables para motor externo	
18 Index (Teilenummern / Seitenzahlen)	18 - 1
Index (part numbers / page numbers)	
Index (numéros de pièces, de pages)	
Index (números de pieza / números de página)	
19 Unterklassen-Ausstattung	
Subclass parts	
Composition des sous-classes	
Composición de las subclases	
19.01 Nähwerkzeuge (PFAFF 939 U)	19 - 2
Gauge parts (PFAFF 939 U)	
Organes de couture (PFAFF 939 U)	
Organos de costura (PFAFF 939 U)	
19.02 Nähwerkzeuge (PFAFF 3704)	19 - 3
Gauge parts (PFAFF 3704)	
Organes de couture (PFAFF 3704)	
Organos de costura (PFAFF 3704)	

Achtung!



Wir machen ausdrücklich darauf aufmerksam, daß Ersatz- und Zubehörteile, die nicht von uns geliefert werden, auch nicht von uns geprüft und freigegeben sind. Der Einbau und / oder die Verwendung solcher Produkte kann daher u. Umständen konstruktiv vorgegebene Eigenschaften Ihrer Maschine negativ verändern. Für Schäden, die durch die Verwendung von Nicht-Originalteilen entstehen, übernehmen wir keine Haftung!

Caution!



We warn you expressively that spare parts and accessories that are not supplied by us are not tested and released by us. Fitting or using these products may therefore have negative influences on features that depend on the machine design. We are not liable for any damage caused by the use of non-Pfaff parts!

Attention!



Nous attirons expressément votre attention sur le fait que les pièces de rechange et accessoires qui n'ont pas été livrés par nous n'ont pas non plus été contrôlés et agréés par nous. C'est pourquoi le montage et/ou l'utilisation de telles pièces peut éventuellement entraîner l'altération des caractéristiques de construction de votre machine. Par conséquent, nous n'assumons aucune responsabilité pour les dommages causés par l'emploi de pièces qui ne sont pas d'origine!

¡Atención!



Se hace observar que en el caso de piezas de recambio y accesorios que no hayan sido suministrados por nosotros, quiere decir que non han sido sometidas por nuestra parte a un control y que no se les ha dado el visto bueno. Por esta razón, el montaje y/o empleo de tales productos puede repercutir negativamente en las características previstas en su máquina. ¡Para los daños que eventualmente pudiesen presentarse al utilizar piezas no originales, no asumimos ninguna garantía!

- Die Seriennummer der Maschine, für die diese Teileliste Gültigkeit hat, ist auf der Titelseite aufgeführt.
 - Alle Teile sind so abgebildet, wie sie in der Maschine funktionsmäßig zusammengehören.
 - Gestrichelt dargestellte Teile zeigen angrenzende Teile aus anderen Funktionsgruppen.
 - Im oberen Teil der Bildseiten befindet sich eine Gesamtansicht der Maschine .
 - Der Einbauort der dargestellten Teile wird durch eine gerasterte Fläche gekennzeichnet.
 - Einrahmungen auf den Bildseiten zeigen, aus welchen Einzelteilen sich die Gruppenteile zusammensetzen.
 - Die auf den Bildseiten verwendeten Schlüsselzeichen (; 2 ; 3 usw.) sind im Kapitel "Erläuterungen der Schlüsselzeichen" aufgelistet.
-
- The serial number of the machine to which this parts list applies is indicated on the cover page.
 - All parts are illustrated in function groups with the parts which they function together with in the machine.
 - Parts illustrated with broken lines are parts from other function groups which border on the illustrated function group.
 - The above section of the page of illustrations contains a total view of the machine. The place for the installation of the parts pictured here is marked by the grid.
 - The framed-in sections on the illustration pages show the individual parts comprising a group.
 - The key markings used on the illustrated pages (; 2 ; 3 etc.) are listed in the chapter "Explanation of key markings".
-
- Le numéro de série de la machine pour laquelle cette liste de pièces est valable est indiqué sur la première page.
 - Toutes les pièces sont représentées en fonction de leur groupement fonctionnel dans la machine.
 - Les pièces hâchurées indiquent les pièces limitrophes de groupes de fonctions différents.
 - La partie supérieure des pages de figures comprend une présentation globale de la machine. L'emplacement des pièces représentées est signalé par quadrillages.
 - Les parties encadrées sur les pages à illustrations représentent les pièces individuelles formant groupe.
 - Vous trouverez au chapitre "Explication des symboles" une liste des symboles utilisés sur les pages de figures (; 2 ; 3 etc.)
-
- El número de serie de la máquina para la cual tiene validez esta lista de piezas va indicado en la página de título.
 - Odas las piezas están ilustradas tal como aparecen en la máquina para su funcionamiento.
 - Las piezas representadas con rayitas muestran piezas colindantes de otros grupos de funciones.
 - En la parte superior de las páginas ilustradas se puede ver una vista en conjunto de la máquina.
 - El lugar de montaje de la pieza representada va caracterizada mediante una superficie reticulada.
 - Los recuadros en las páginas ilustradas indican las piezas individuales de que se componen los grupos.
 - Los signos clave (; 2 ; 3 etc.) empleados en las páginas con ilustraciones van listados en el capítulo "Explicaciones de los signos clave".

- Unterklassenabhängig, Teilenummer siehe Unterklassen-Ausstattung.**
Subclas-dependent, for part number see subclass parts listing.
Fonction de la sous-classe; pour le numéro de la pièce, voir "Équipement de sous-classes".
Dependientes de la subclase, para el número de pieza véase "Dotación de subclases".
- B** **Maschinen-Ausstattung für mittlere Materialien.**
Model B for sewing medium-weight materials.
Modèle B pour la couture de matières moyennes.
Tipo B para materiales semiligeros.
- N24** **2,5 mm Schubweg des hinteren und 4,5 mm des vorderen Stoffschiebers.**
2.5 mm feed motion of the rear and 4.5 mm of the front feed dog.
griffe arrière pour une longueur d'avance de 2,5 mm et griffe avant pour une longueur d'avance de 4,5 mm.
2,5 mm de recorrido del elemento transportador posterior y 4,5 mm de recorrido del elemento transportador anterior.
- 2** **Markierung (Punkte, Striche oder Zahl) bei Bestellung angeben.**
Marking (dots, strokes or numbers) to be stated on order.
Préciser les repères (points, traits ou chiffres) à la commande.
Señales (puntos, rayas o cifras), indíquese en los pedidos.
- 3** **Geklebt**
Part cemented
Pièce collée
Pieza pegada
- 6** **Nadeldicke und Spitzenform bei Bestellung angeben.**
Needle size and style of point to be stated on order.
Préciser la grosseur de l'aiguille et la forme de la pointe à la commande.
Grosor de aguja y forma de la punta, indíquese en los pedidos.
- 11** **Überstichbreite**
Stitch width
Amplitude zigzag
Ancho de zig-zag
- 26/2** **Stichlängenbegrenzung auf 0,5 mm.**
Stitch leng limited to 0.5 mm.
Limitation de la longueur du point à 0,5 mm.
Limitación del largo de puntada a 0,5 mm.
- 26/3** **Stichlängenbegrenzung auf 1,5 mm.**
Stitch leng limited to 1.5 mm.
Limitation de la longueur du point à 1,5 mm.
Limitación del largo de puntada a 1,5 mm.
- 26/4** **Stichlängenbegrenzung auf 2,5 mm.**
Stitch leng limited to 2.5 mm.
Limitation de la longueur du point à 2,5 mm.
Limitación del largo de puntada a 2,5 mm.
- 27/5** **Eingeklammerte Zahl = Länge in mm.**
Number in brackets = length in mm.
Chiffre entre parenthèses = longueur en mm
Cifra entre paréntesis = largura en mm.

- 28** **Sonderausführung**
Special version
Version spéciale
Tipo especial
- 40/3** **Fetten mit 28-011 202-47; Bestellnummer siehe Seite 14 - 1.**
Grease with 28-011 202-47; for part number see page 14 - 1.
Graiser avec de la graisse 28-011 202-47; n° de commande, voir page 14 - 1.
Engrase con grasa 28-011 202-47; para el Número de pedido véase la página 14 - 1.
- 40/10** **Fetten mit 28-011 201-99; Bestellnummer siehe Seite 14 - 1.**
Grease with 28-011 201-99; for part number see page 14 - 1.
Graiser avec de la graisse 28-011 201-99; n° de commande, voir page 14 - 1.
Engrase con grasa 28-011 201-99; para el Número de pedido véase la página 14 - 1.
- 40/13** **Fetten mit 28-011 202-05; Bestellnummer siehe Seite 14 - 1.**
Grease with 28-011 202-05; for part number see page 14 - 1.
Graiser avec de la graisse 28-011 202-05; n° de commande, voir page 14 - 1.
Engrase con grasa 28-011 202-05; para el Número de pedido véase la página 14 - 1.
- 40/14** **Tränken mit 28-011 201-46; Bestellnummer siehe Seite 14 - 1.**
Soak with 28-011 201-46; for part number see page 14 - 1.
Imbiber d'huile 28-011 201-46; n° de commande, voir page 14 - 1.
Empape con aceite 28-011 201-46; para el Número de pedido véase la página 14 - 1.
- 40/15** **Ölen mit 28-011 201-46; Bestellnummer siehe Seite 14 - 1.**
Oil with 28-011 201-46; for part number see page 14 - 1.
Huiler par 28-011 201-46; n° de commande, voir page 14 - 1.
Lubrifique con 28-011 201-46; para el Número de pedido véase la página 14 - 1.
- 40/23** **Tränken mit 28-011 201-05; Bestellnummer siehe Seite 14 - 1.**
Soak with 28-011 201-05; for part number see page 14 - 1.
Imbiber d'huile 28-011 201-05; n° de commande, voir page 14 - 1.
Empape con aceite 28-011 201-05; para el Número de pedido véase la página 14 - 1.
- 60** **Wahlweise**
Optional
Au choix
Opcional
- 81/3** **Verwendung je nach Bedarf.**
To be used as required.
Utilisation en fonction besoins.
Utilización según sea necesario.
- 90/1** **Für Wechselstrom**
For single-phase A.C.
Pour du courant alternatif
Para corriente alterna monofásica
- 96** **Länge angeben.**
State length.
Préciser longueur.
Indíquese la largura .

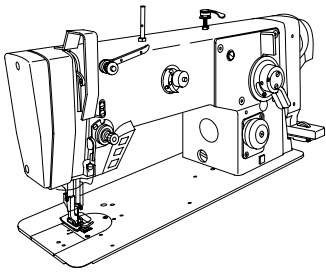

Gehäuseteile
Housing sections
Parties du corps
Piezas del cárter PFAFF 939-U

3.01

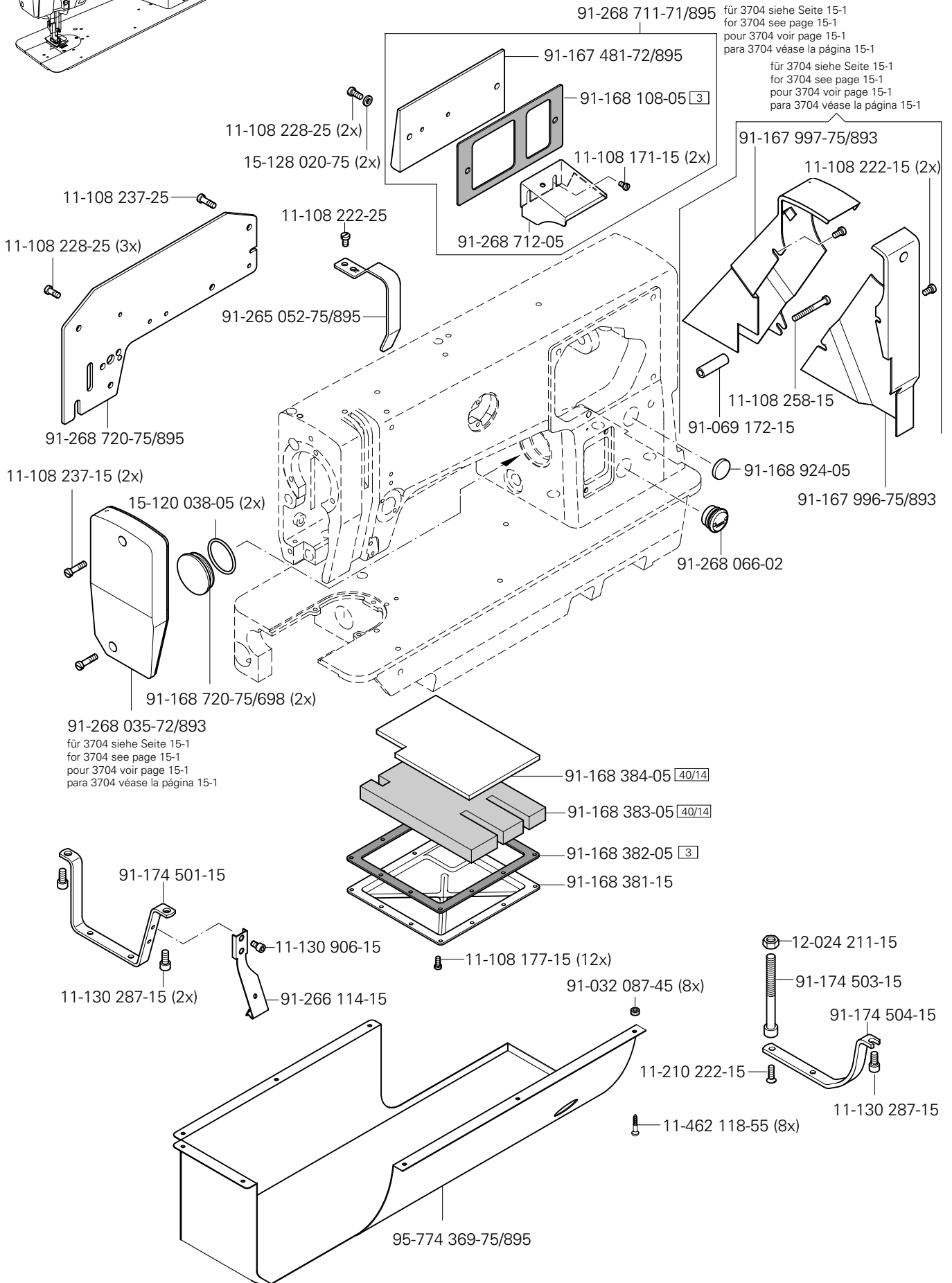

3.02

Kopfteile
Needle head parts
Pièces de tête
Piezas de la cabeza PFAFF 939-U

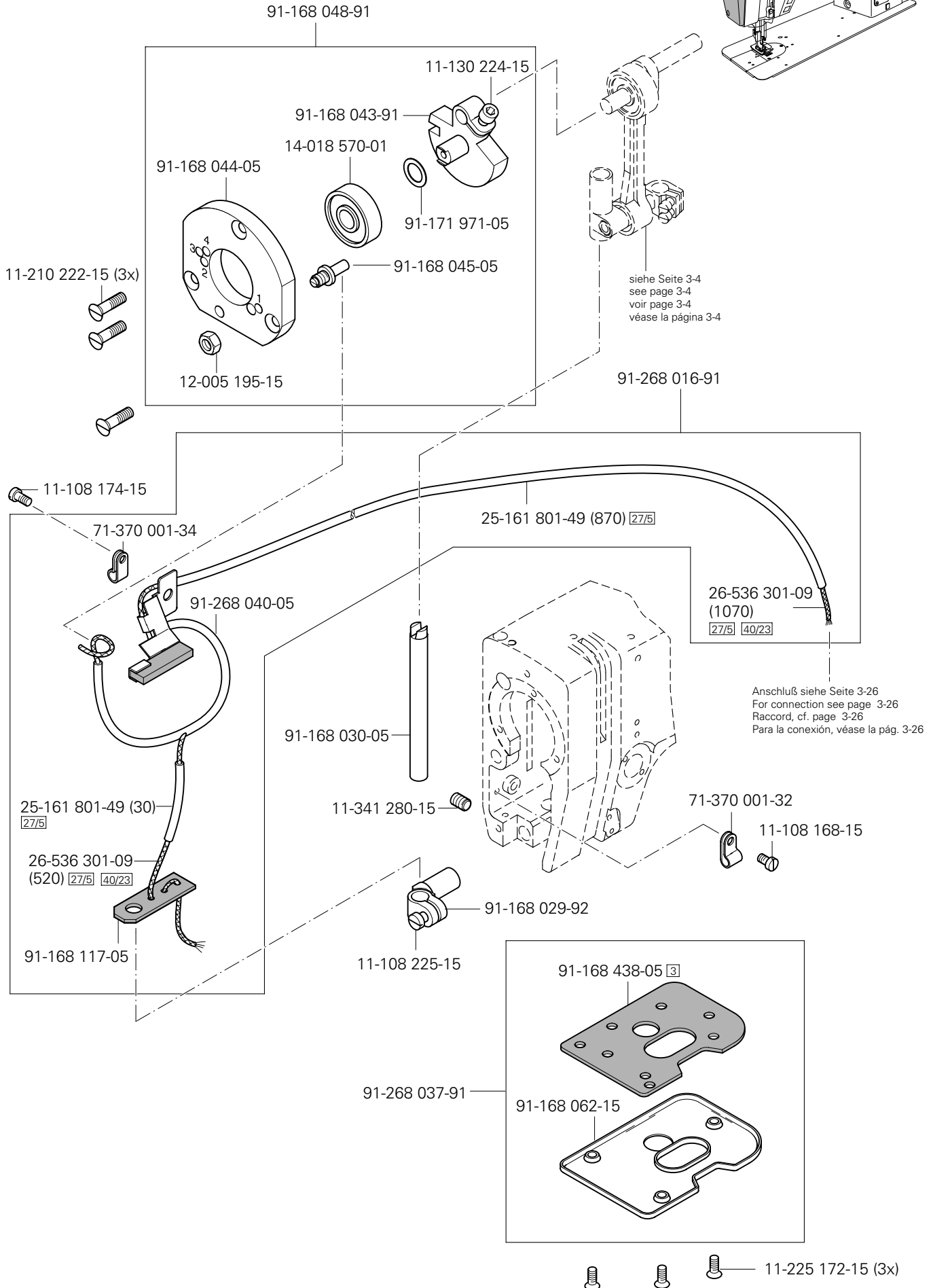
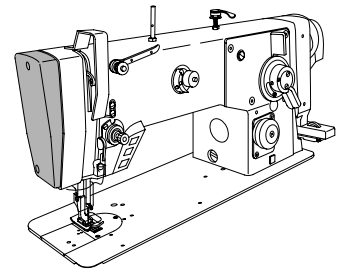

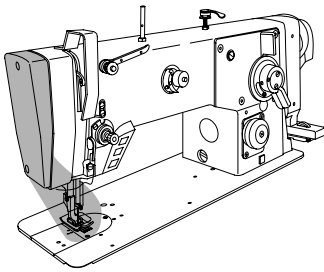

Kopfteil
Needle head parts
Pièces de tête
Piezas de la cabeza PFAFF 939-U

3.02

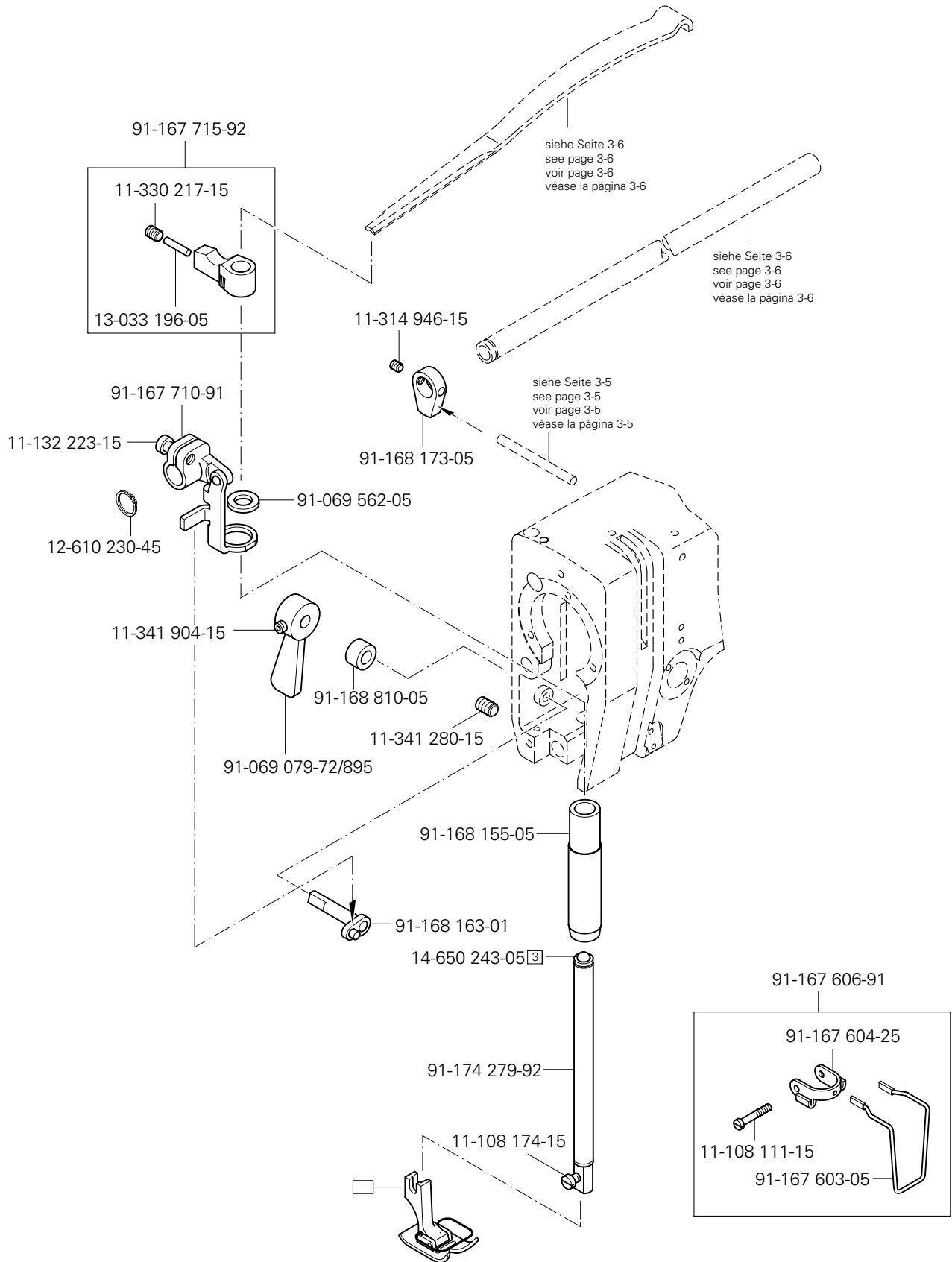

3.02

Kopfteile Needle head parts Pièces de tête Piezas de la cabeza PFAFF 939-U

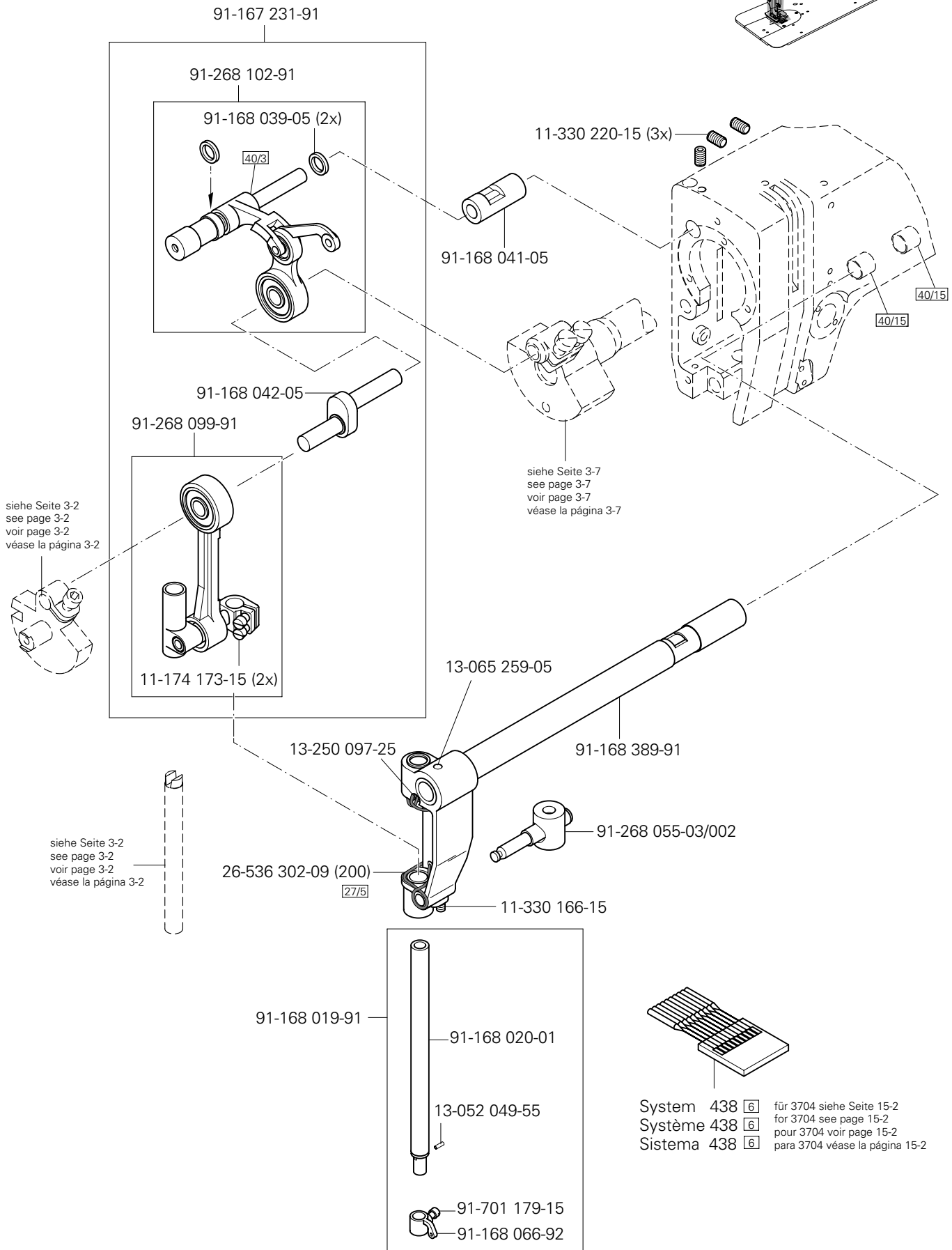
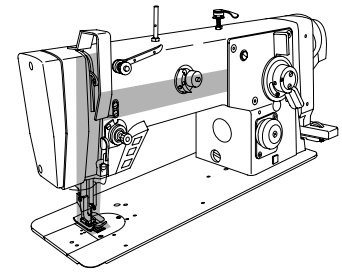

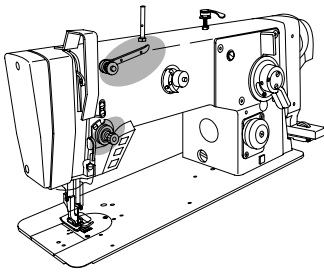

Kopfteile
 Needle head parts
 Pièces de tête
 Piezas de la cabeza PFAFF 939-U

3.02

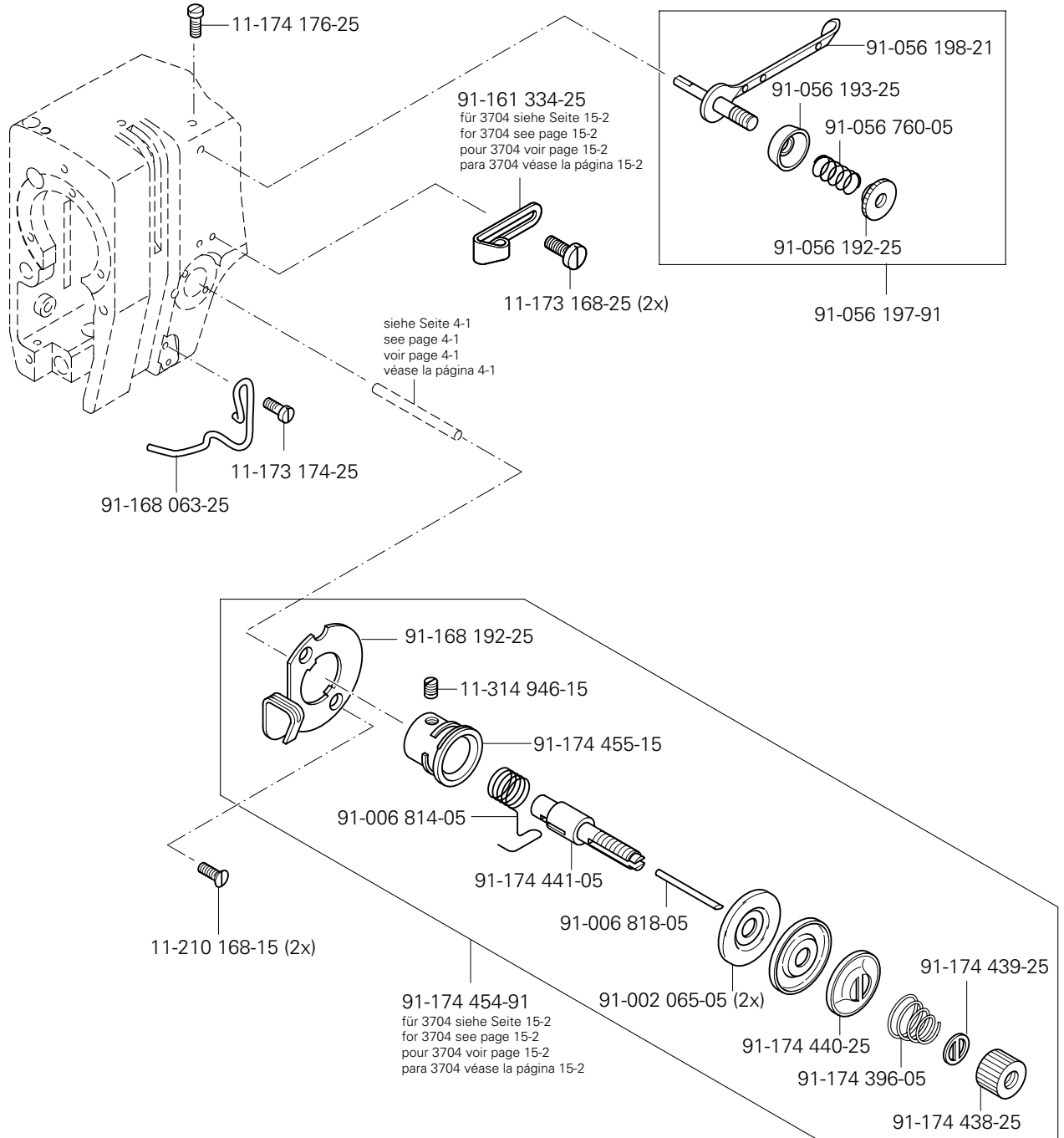

3.03

Armteile
Arm parts
Pièces de bras
Piezas del brazo PFAFF 939-U

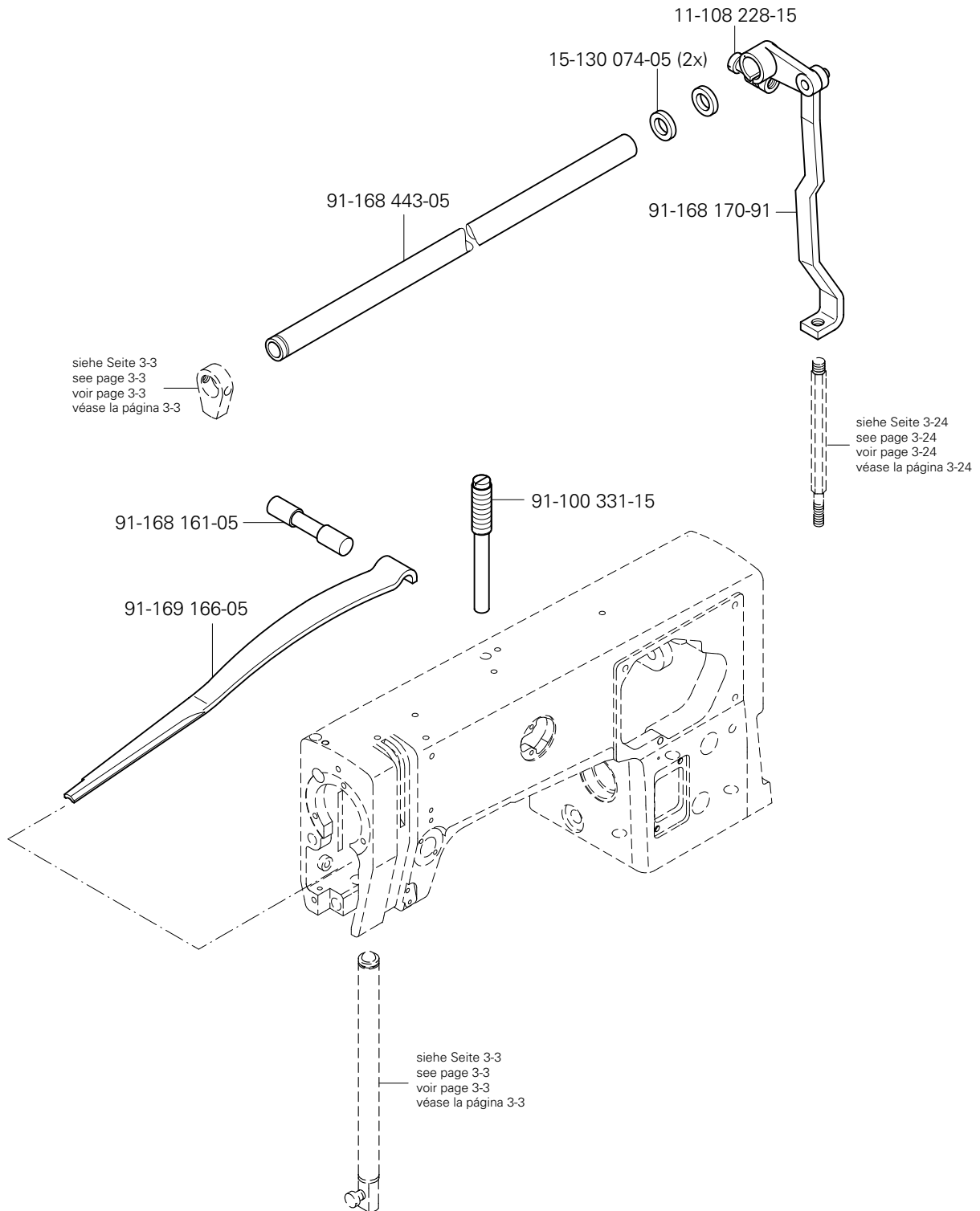
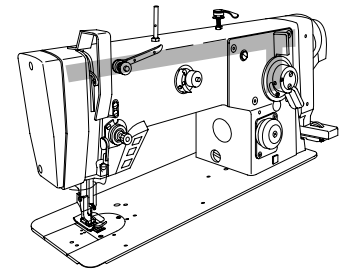

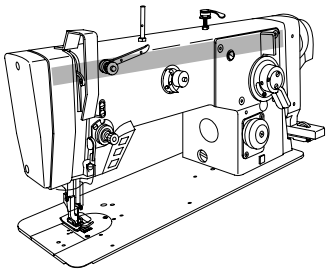

Armteile
 Arm parts
 Pièces de bras
 Piezas del brazo PFAFF 939-U

3.03

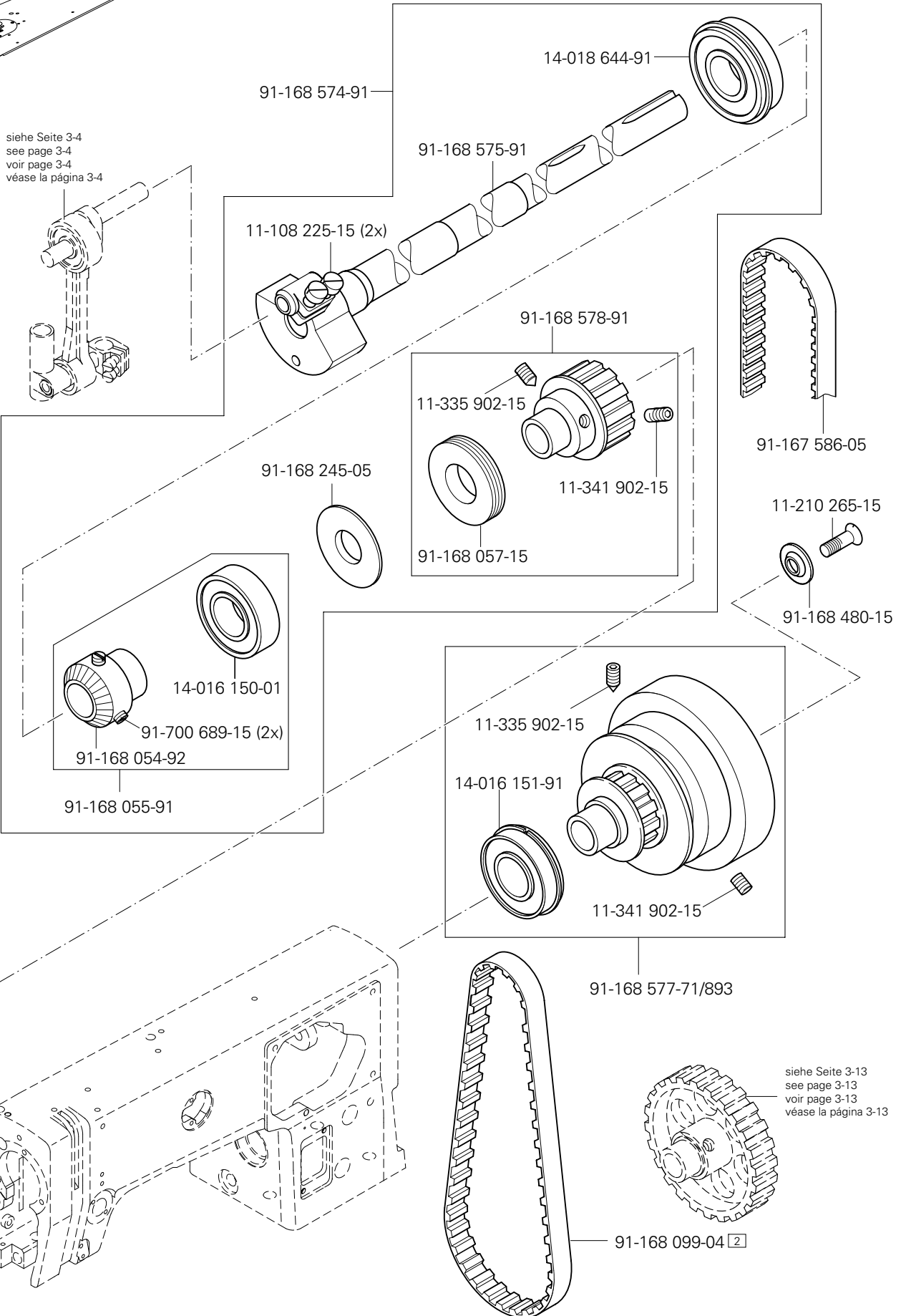

3.03

Armteile
 Arm parts
 Pièces de bras
 Piezas del brazo PFAFF 939-U

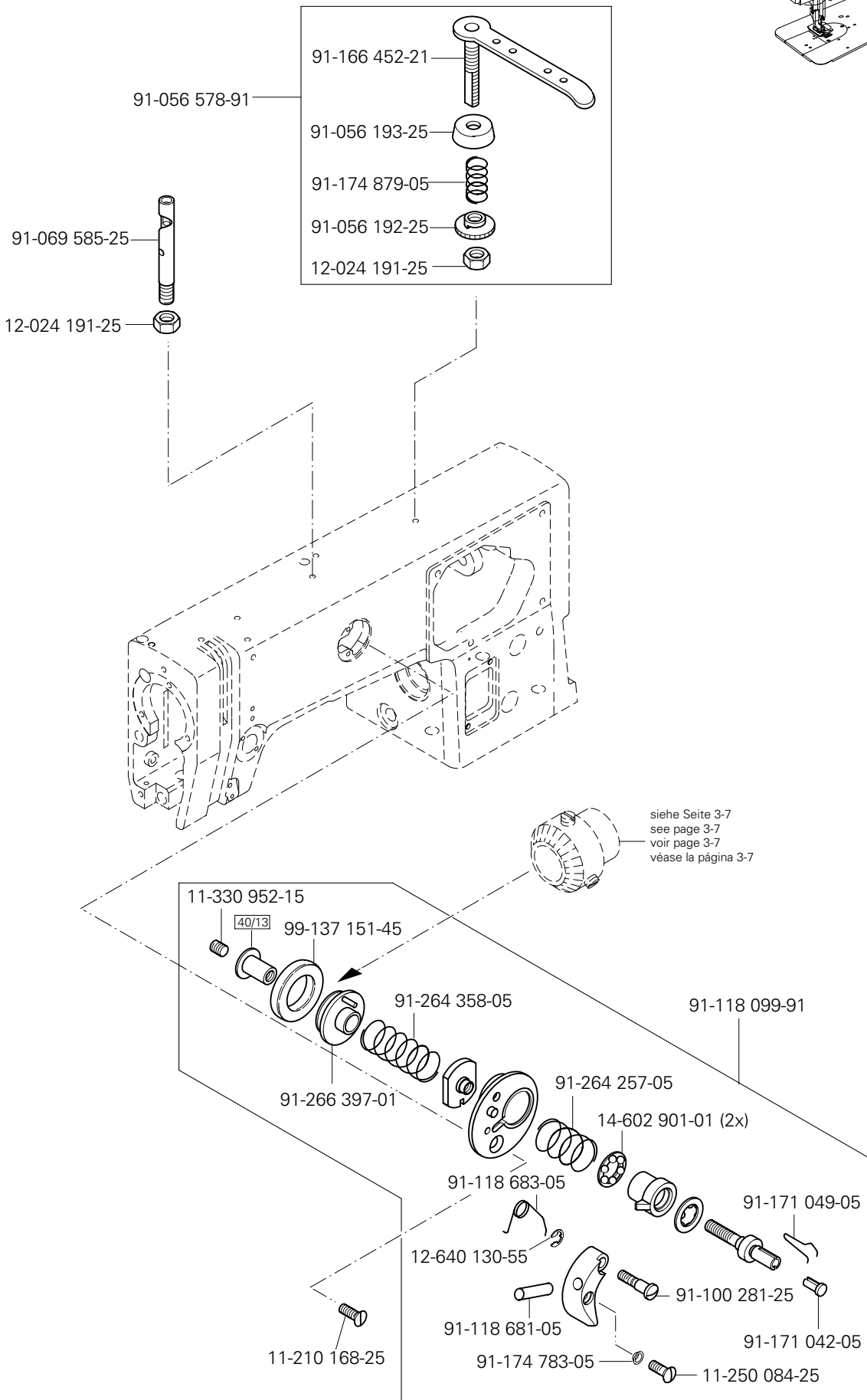
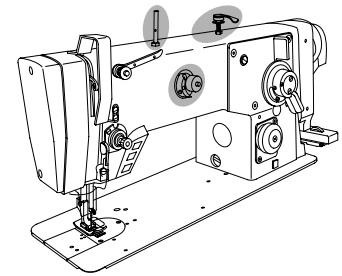

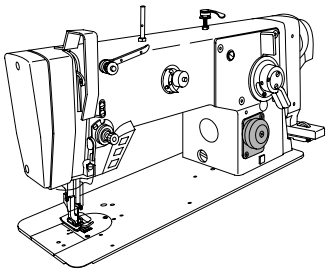

Armteile
 Arm parts
 Pièces de bras
 Piezas del brazo PFAFF 939-U

3.03

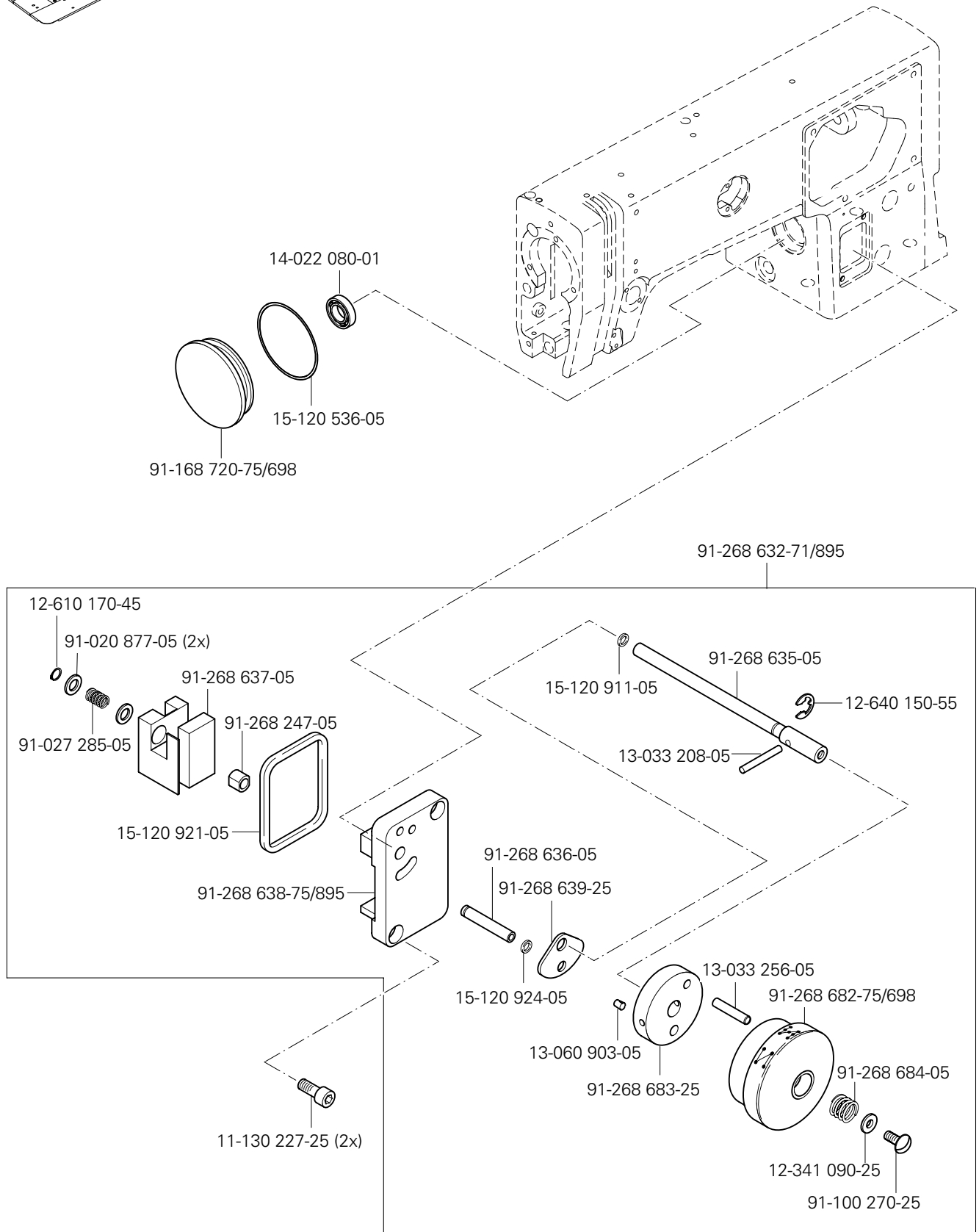

3.03

Armteile Arm parts Pièces de bras Piezas del brazo PFAFF 939-U

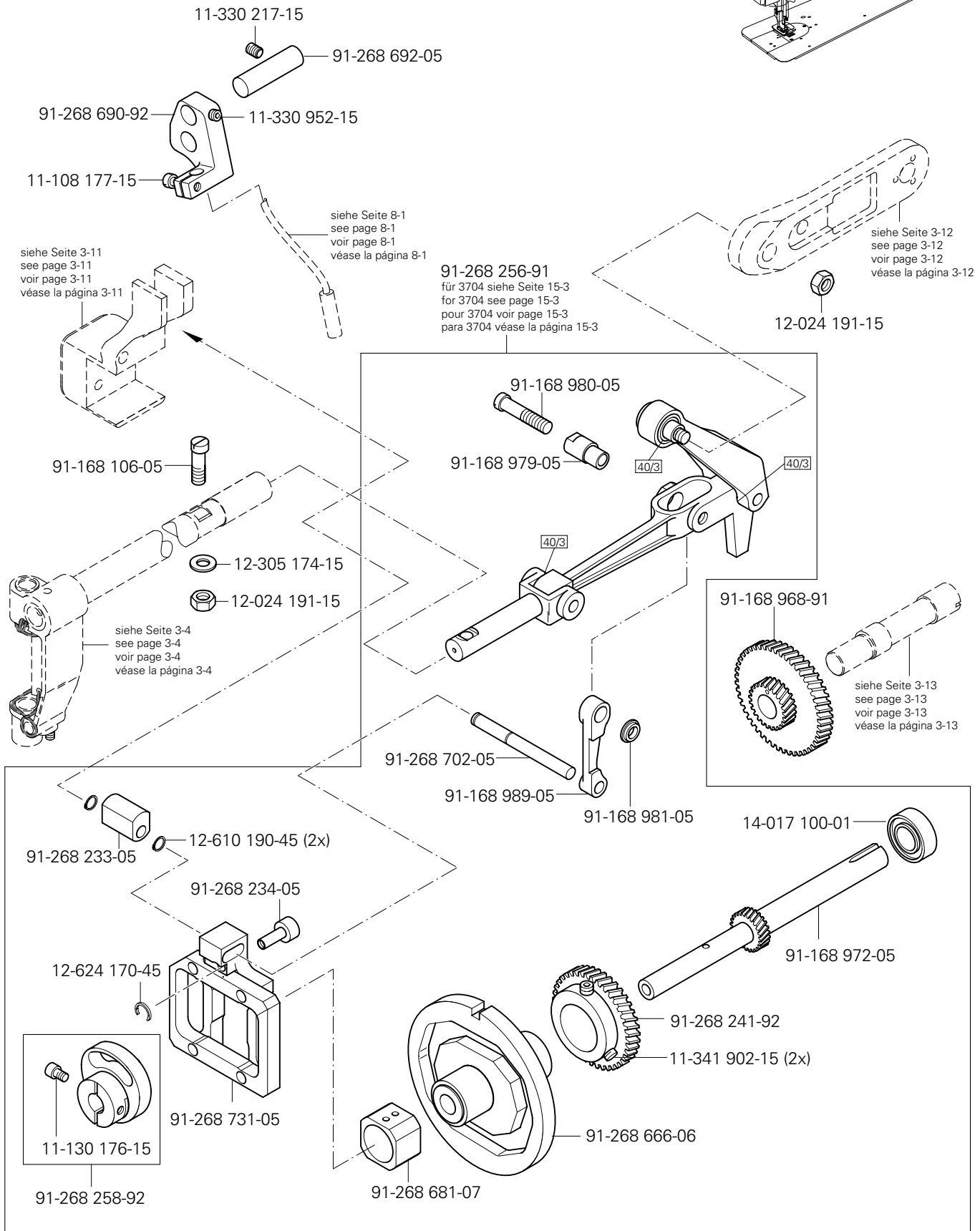
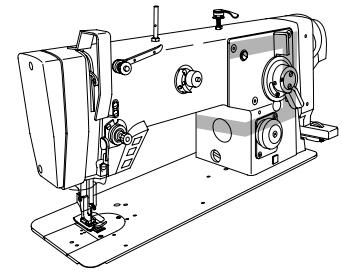

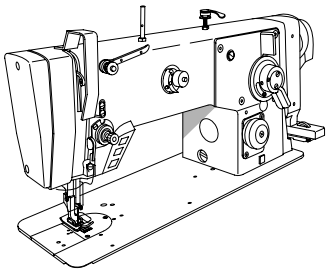

Armteile
 Arm parts
 Pièces de bras
 Piezas del brazo PFAFF 939-U

3.03

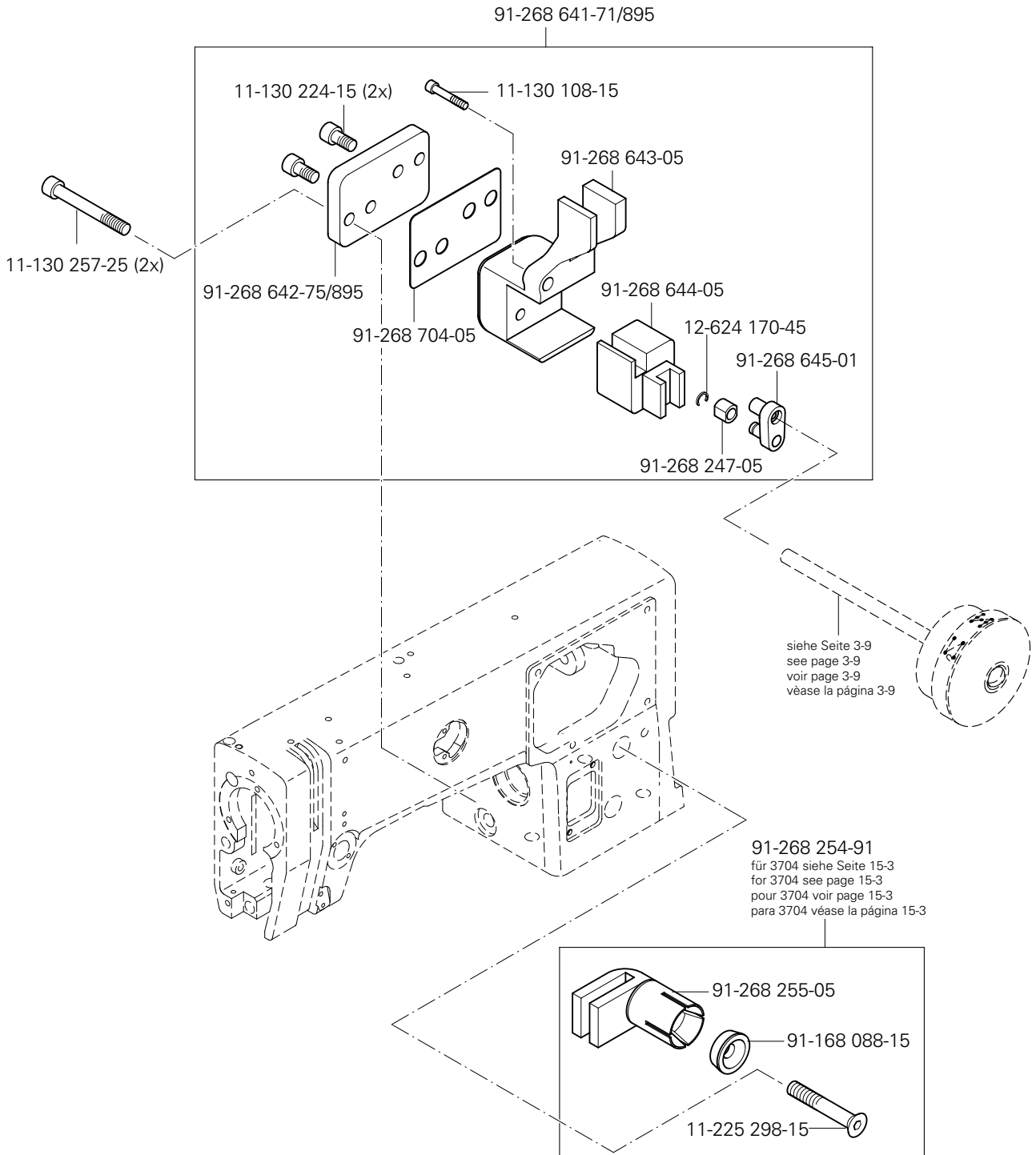

3.03

Armteile
 Arm parts
 Pièces de bras
 Piezas del brazo PFAFF 939-U

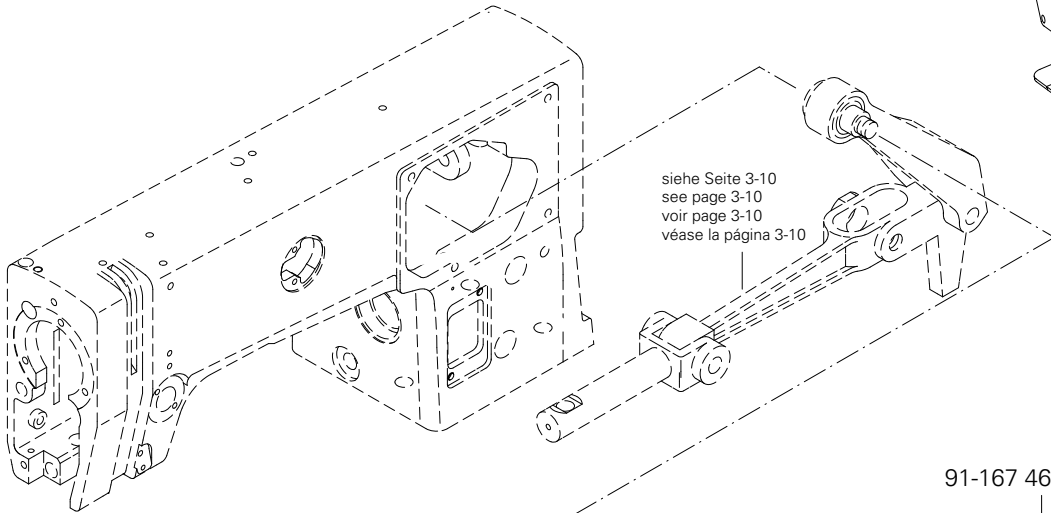
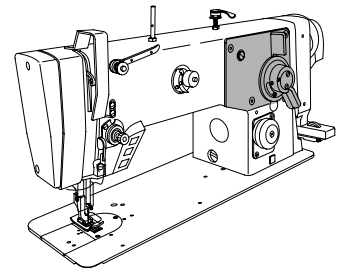

siehe Seite 3-10
 see page 3-10
 voir page 3-10
 véase la página 3-10

91-167 463-71/893

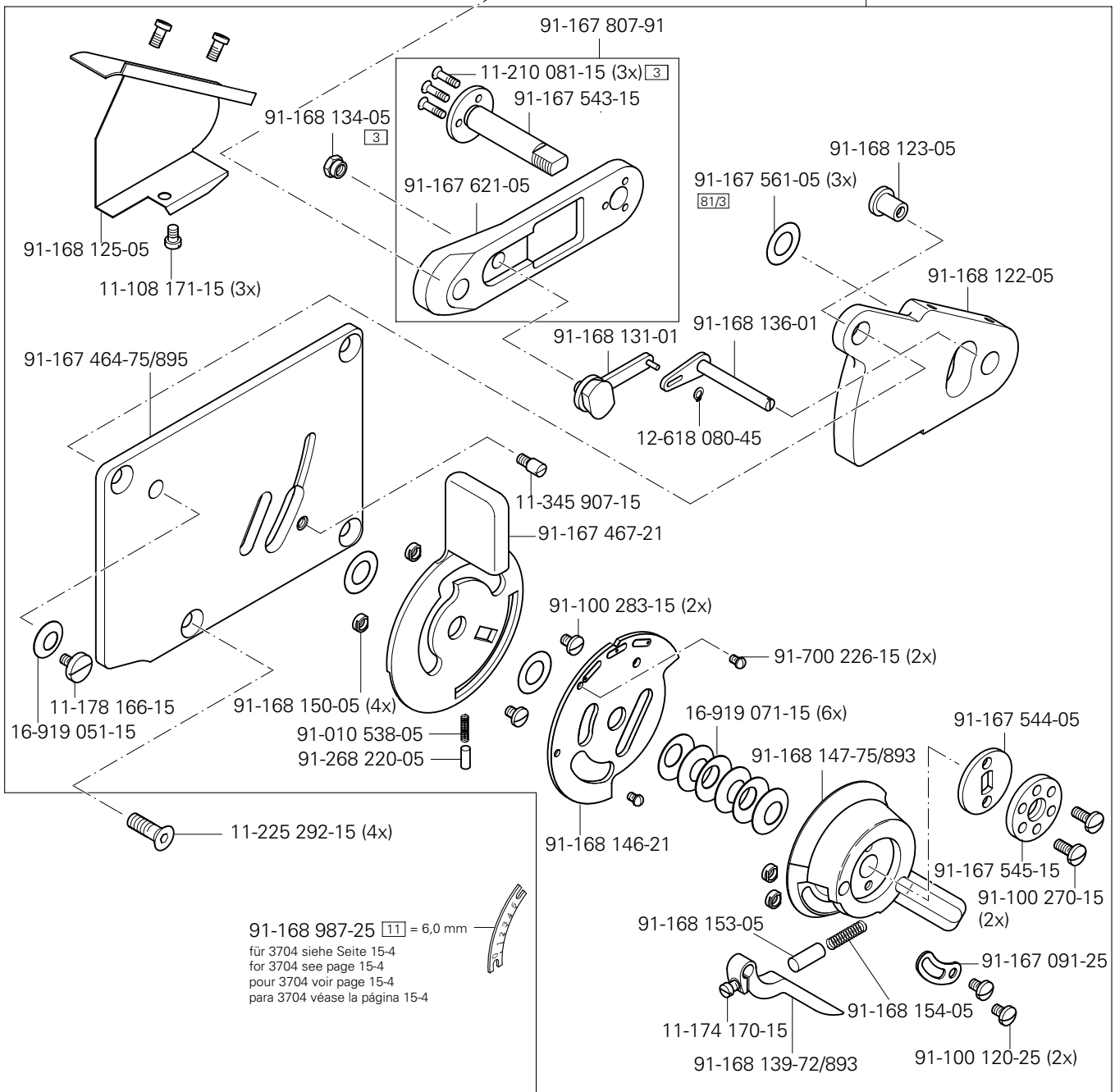

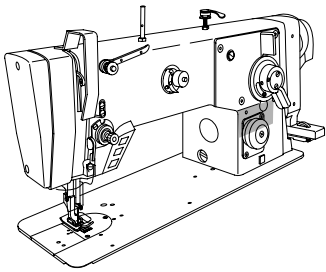

Armteile
 Arm parts
 Pièces de bras
 Piezas del brazo PFAFF 939-U

3.03

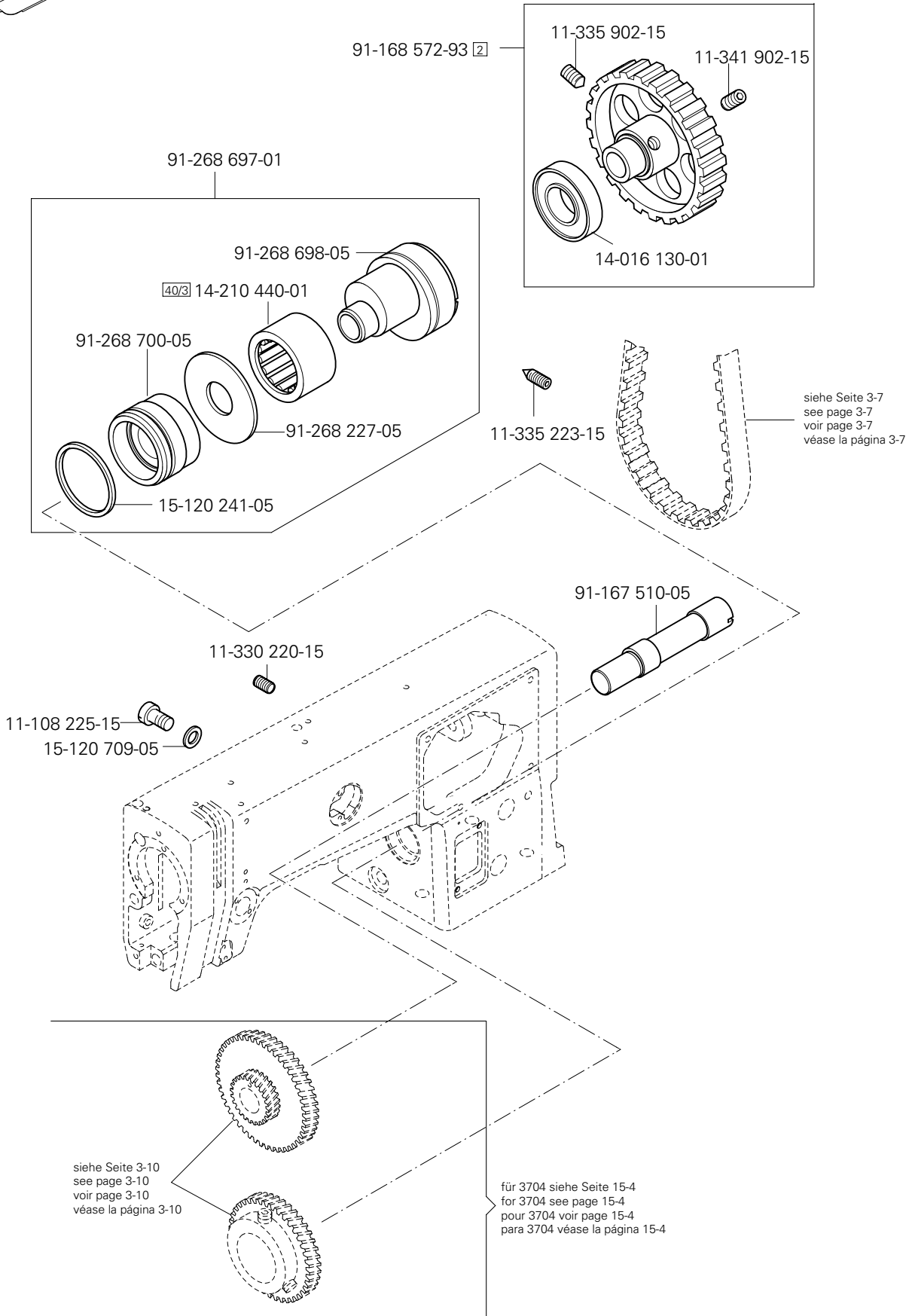

3.03

Armteile
 Arm parts
 Pièces de bras
 Piezas del brazo PFAFF 939-U

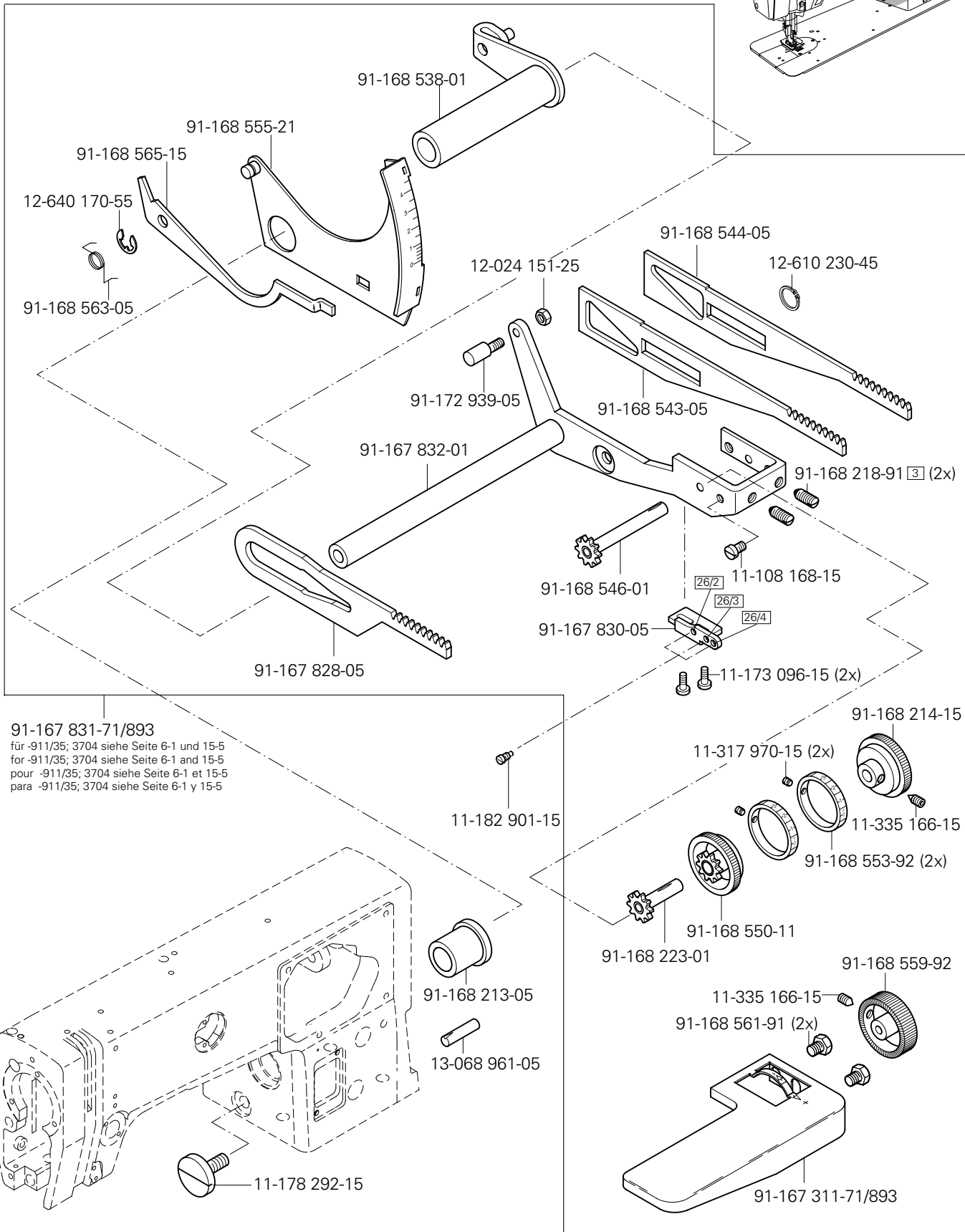
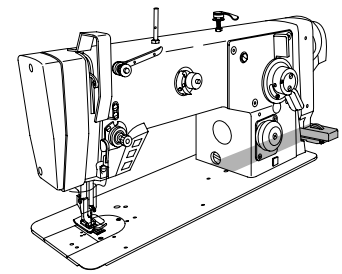

91-167 831-71/893
 für -911/35; 3704 siehe Seite 6-1 und 15-5
 for -911/35; 3704 siehe Seite 6-1 and 15-5
 pour -911/35; 3704 siehe Seite 6-1 et 15-5
 para -911/35; 3704 siehe Seite 6-1 y 15-5

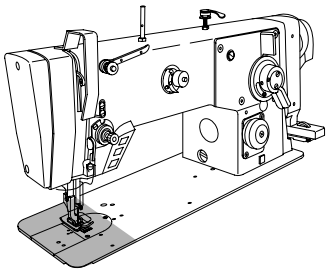

Grundplattenteile
 Bedplate parts
 Pièces du plateau fondamental
 Piezas del cárter

PFAFF 939-U

3.04

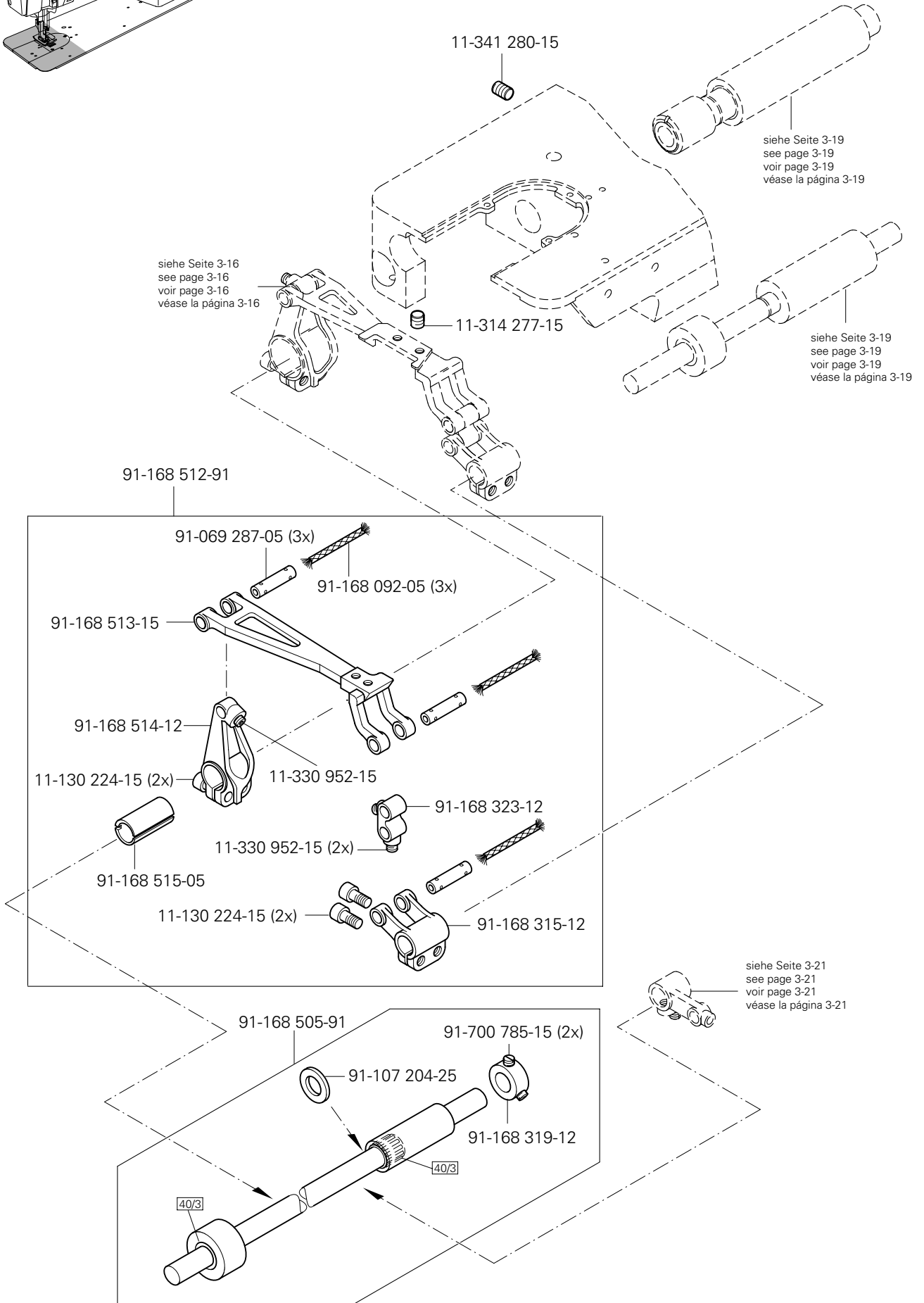

3.04

Grundplattenteile
 Bedplate parts
 Pièces du plateau fondamental
 Piezas del cárter

PFAFF 939-U

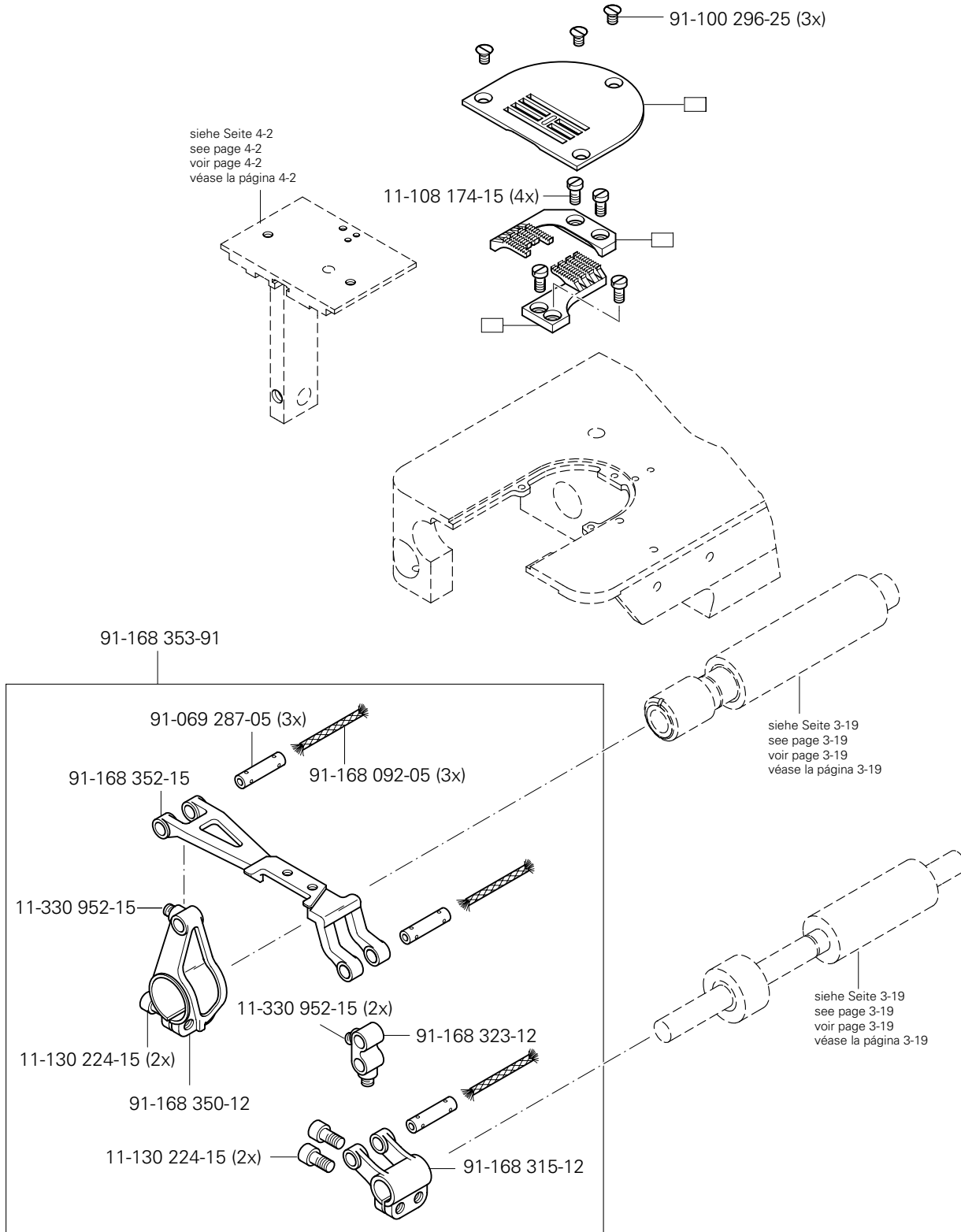
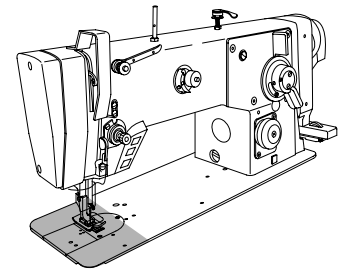

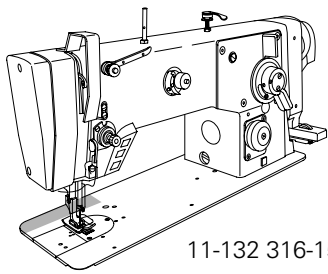

Grundplattenteile
Bedplate parts
Pièces du plateau fondamental
Piezas del cárter

PFAFF 939-U

3.04

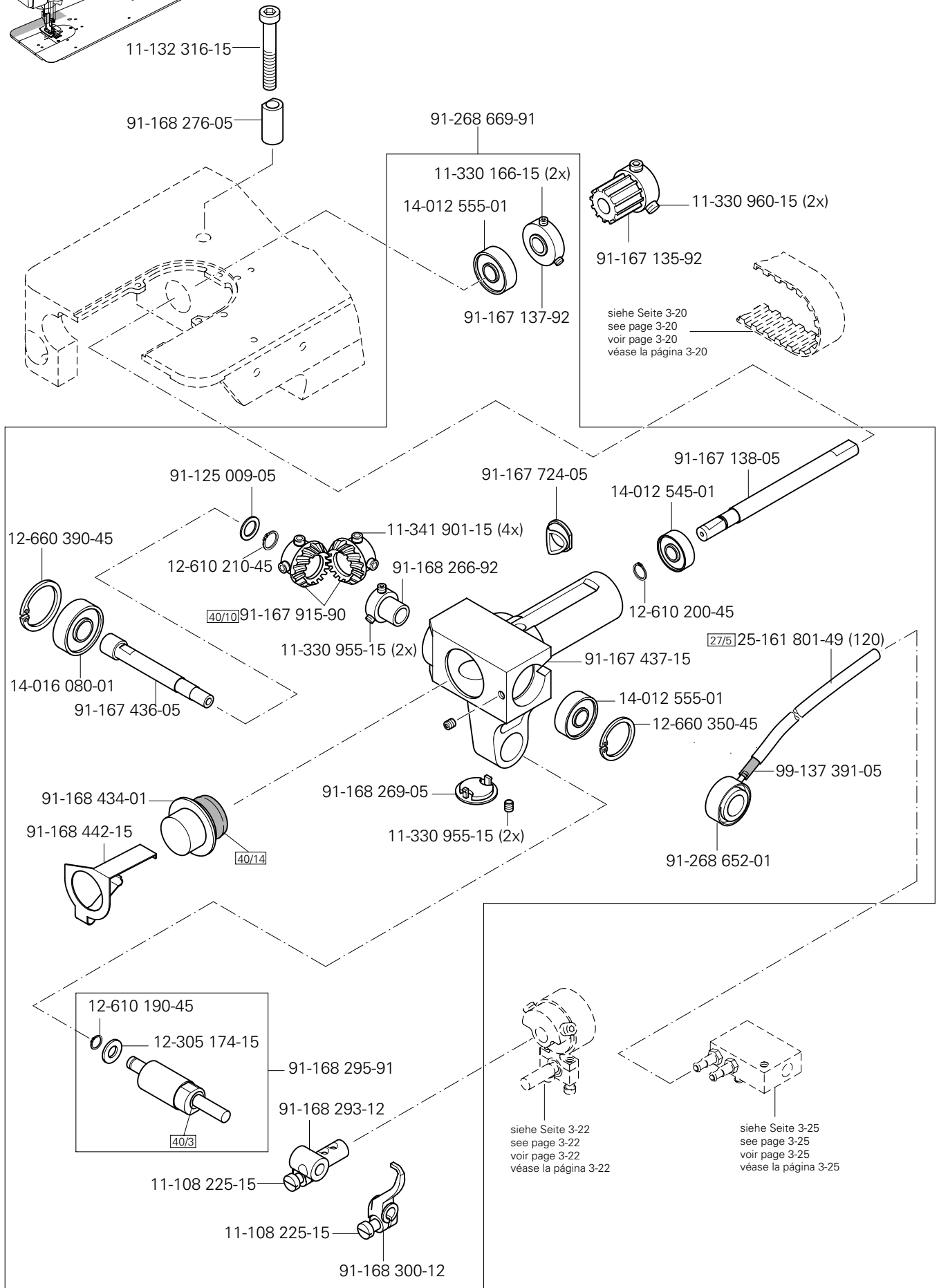

3.04

Grundplattenteile
 Bedplate parts
 Pièces du plateau fondamental
 Piezas del cárter

PFAFF 939-U

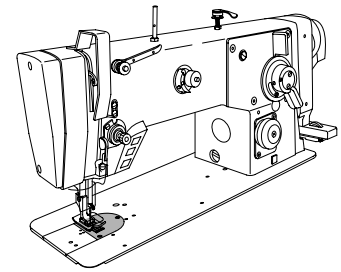

siehe Seite 3-17
 see page 3-17
 voir page 3-17
 véase la página 3-17

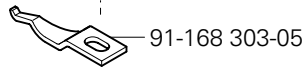
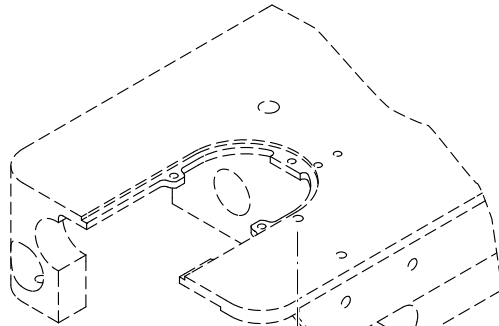

91-168 303-05



siehe Seite 4-2
 see page 4-2
 voir page 4-2
 véase la página 4-2

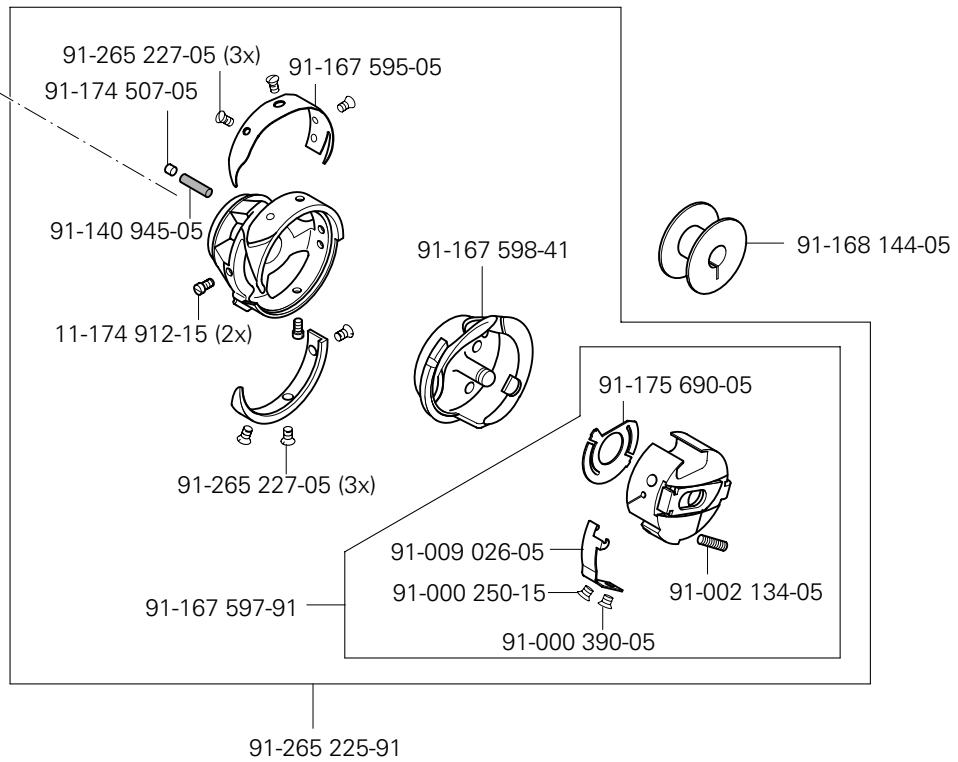
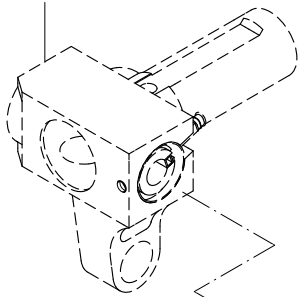

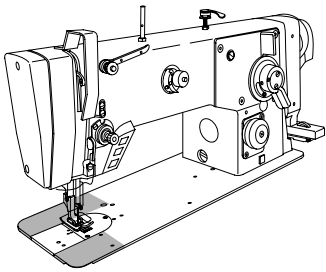

Grundplattenteile
 Bedplate parts
 Pièces du plateau fondamental
 Piezas del cárter

PFAFF 939-U

3.04

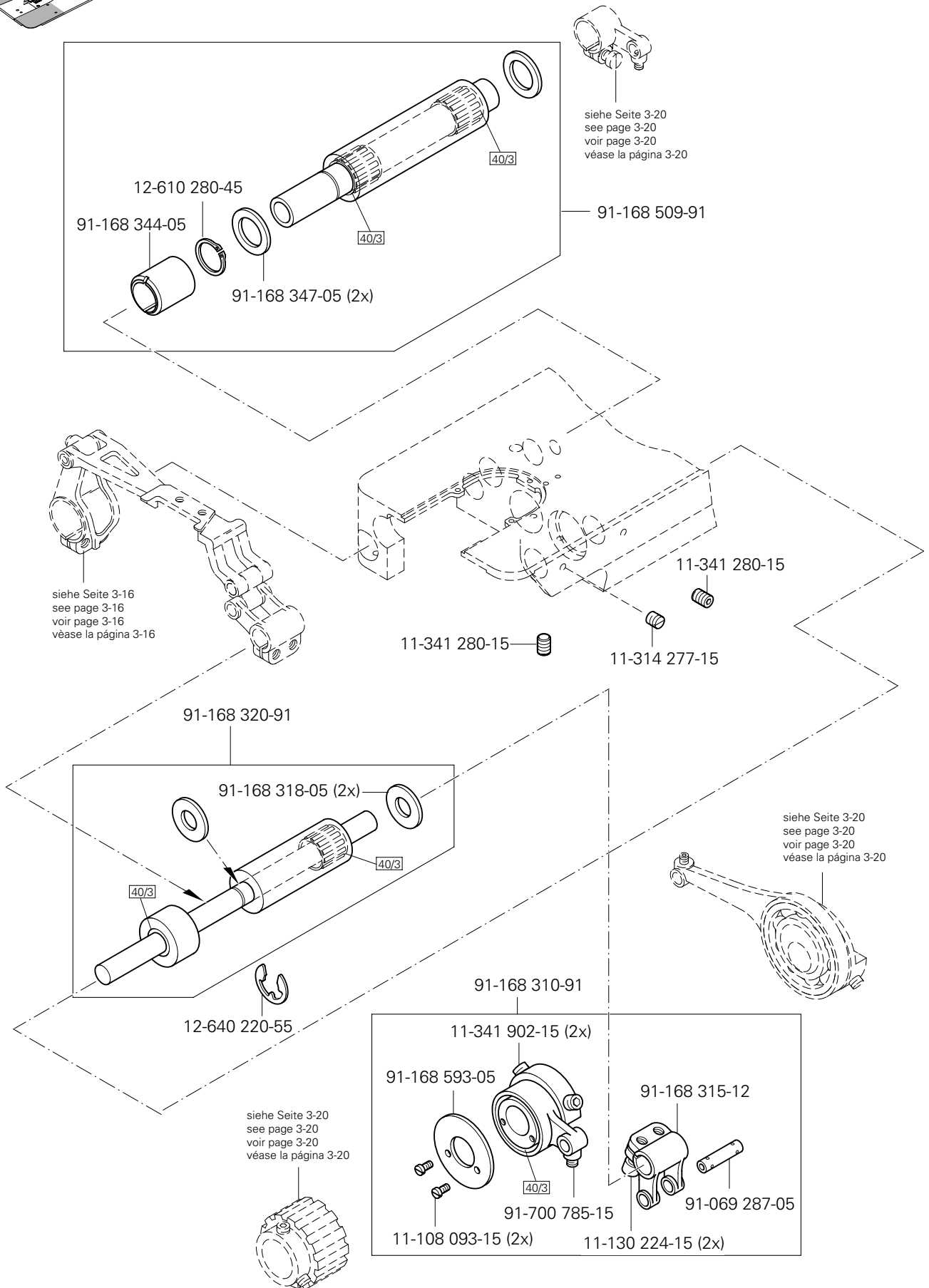

3.04

Grundplattenteile
Bedplate parts
Pièces du plateau fondamental
Piezas del cárter

PFAFF 939-U

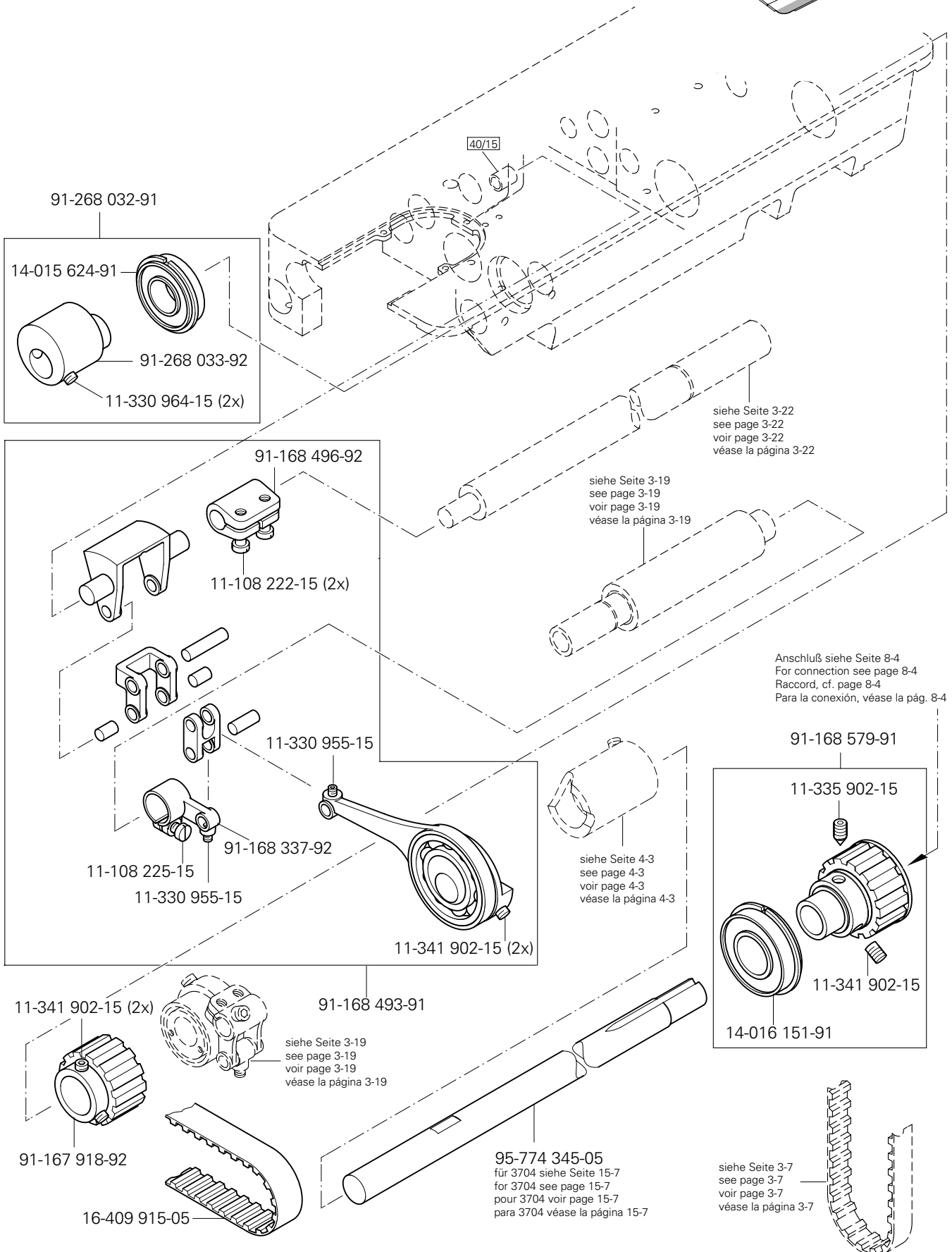
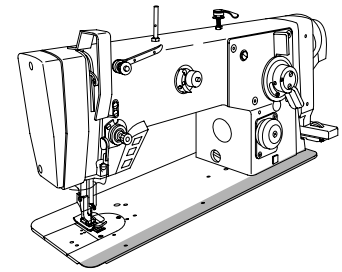

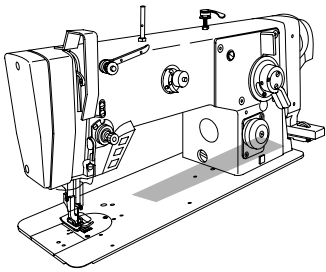

Grundplattenteile
 Bedplate parts
 Pièces du plateau fondamental
 Piezas del cárter

PFAFF 939-U

3.04

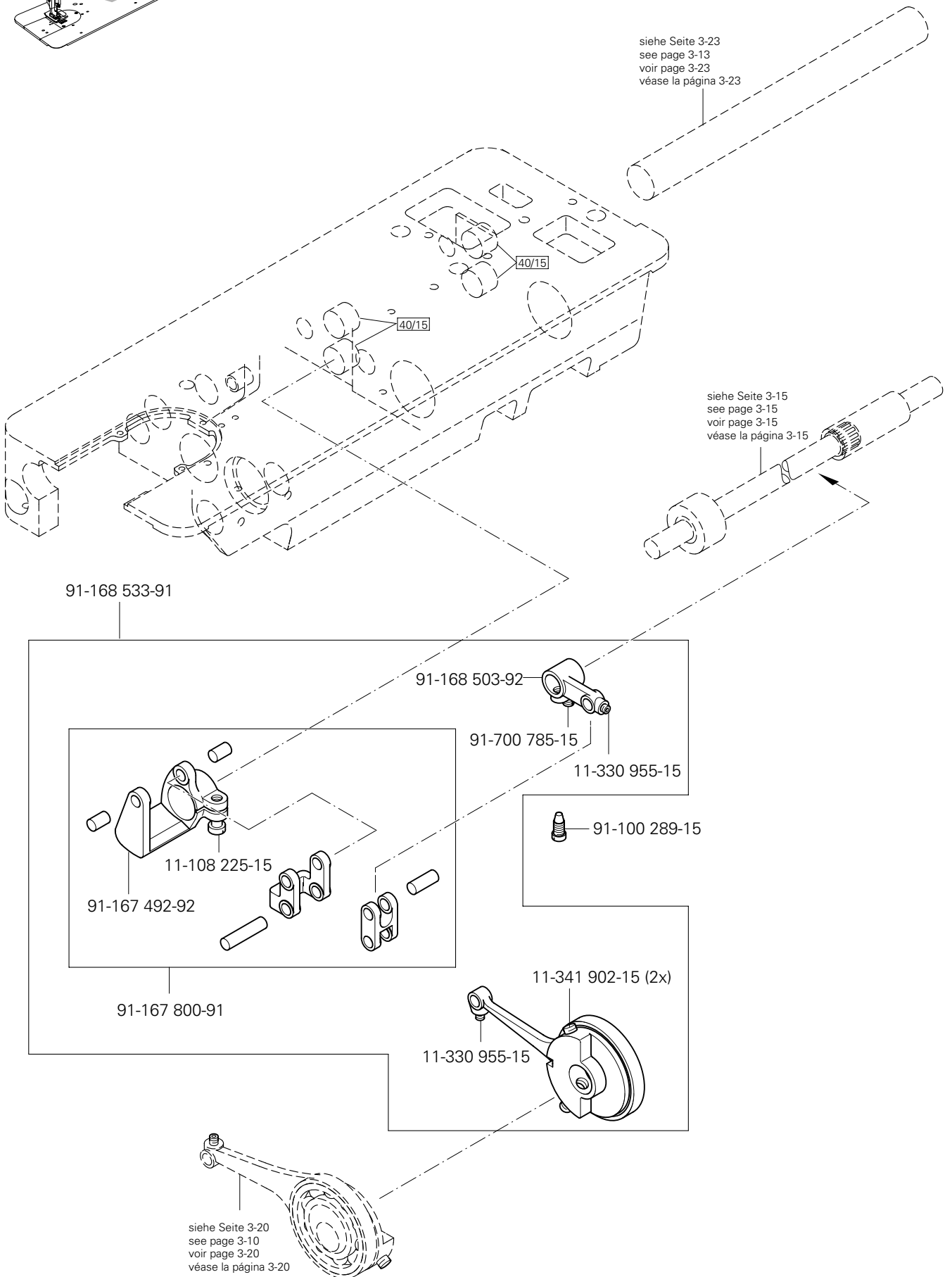

3.04

Grundplattenteile Bedplate parts Pièces du plateau fondamental Piezas del cárter

PFAFF 939-U

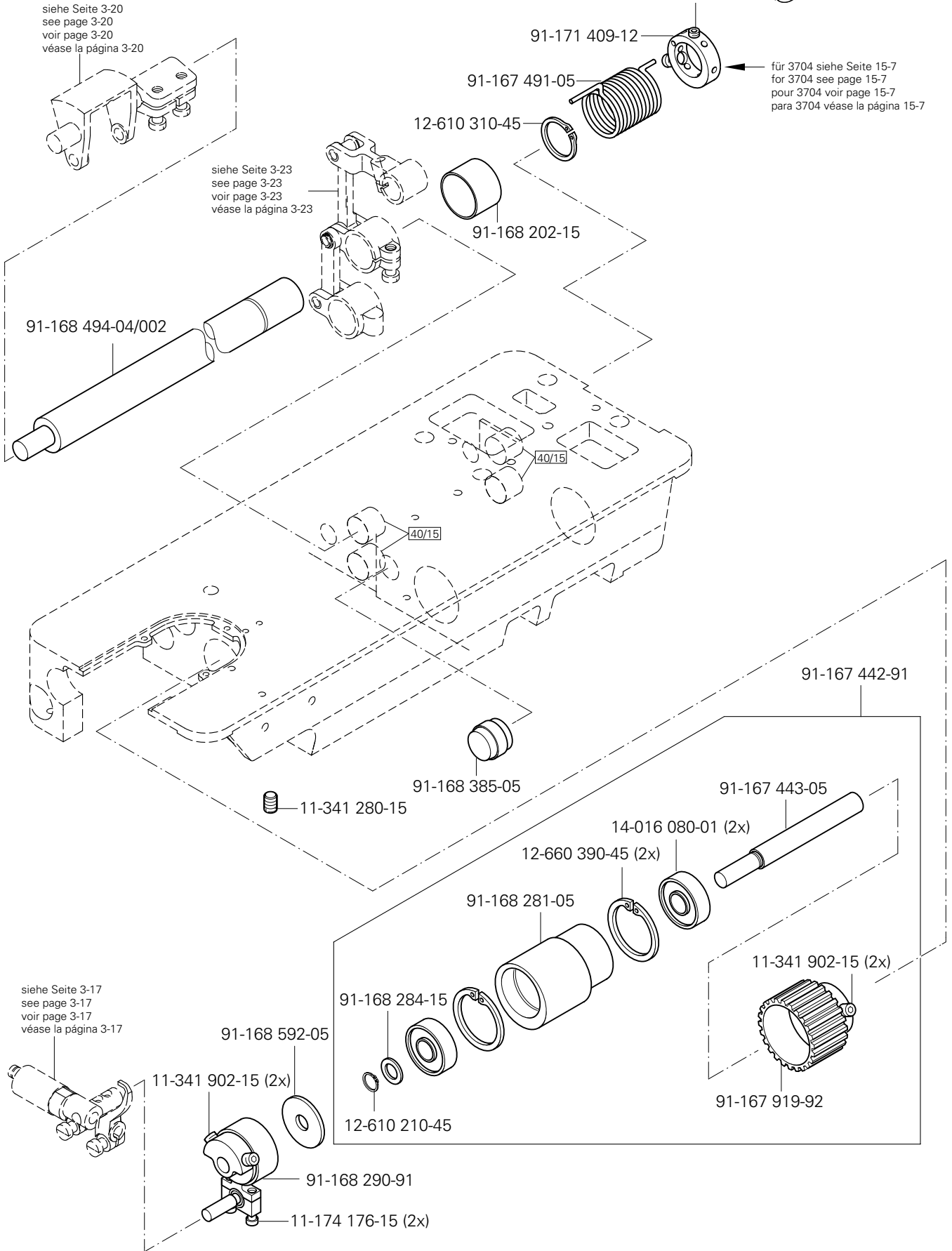
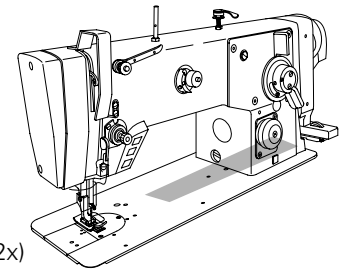

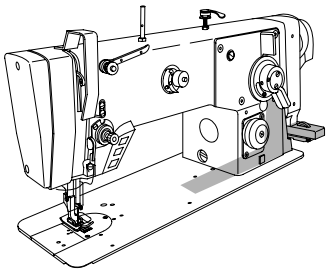

Grundplattenteile
Bedplate parts
Pièces du plateau fondamental
Piezas del cárter

PFAFF 939-U

3.04

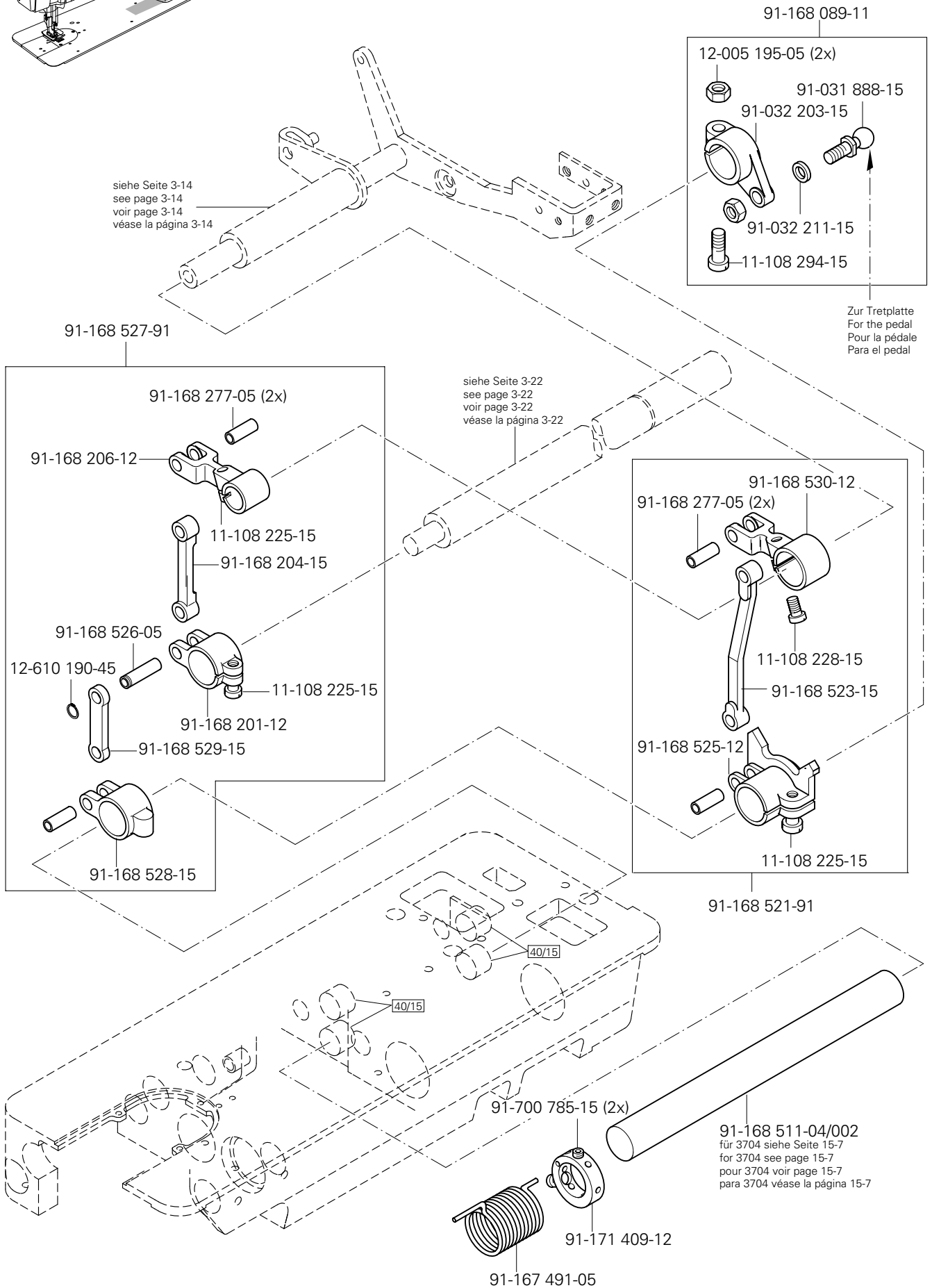

3.04

Grundplattenteile
 Bedplate parts
 Pièces du plateau fondamental
 Piezas del cárter

PFAFF 939-U

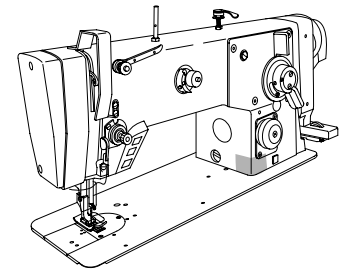

siehe Seite 3-6
 see page 3-6
 voir page 3-6
 véase la página 3-6

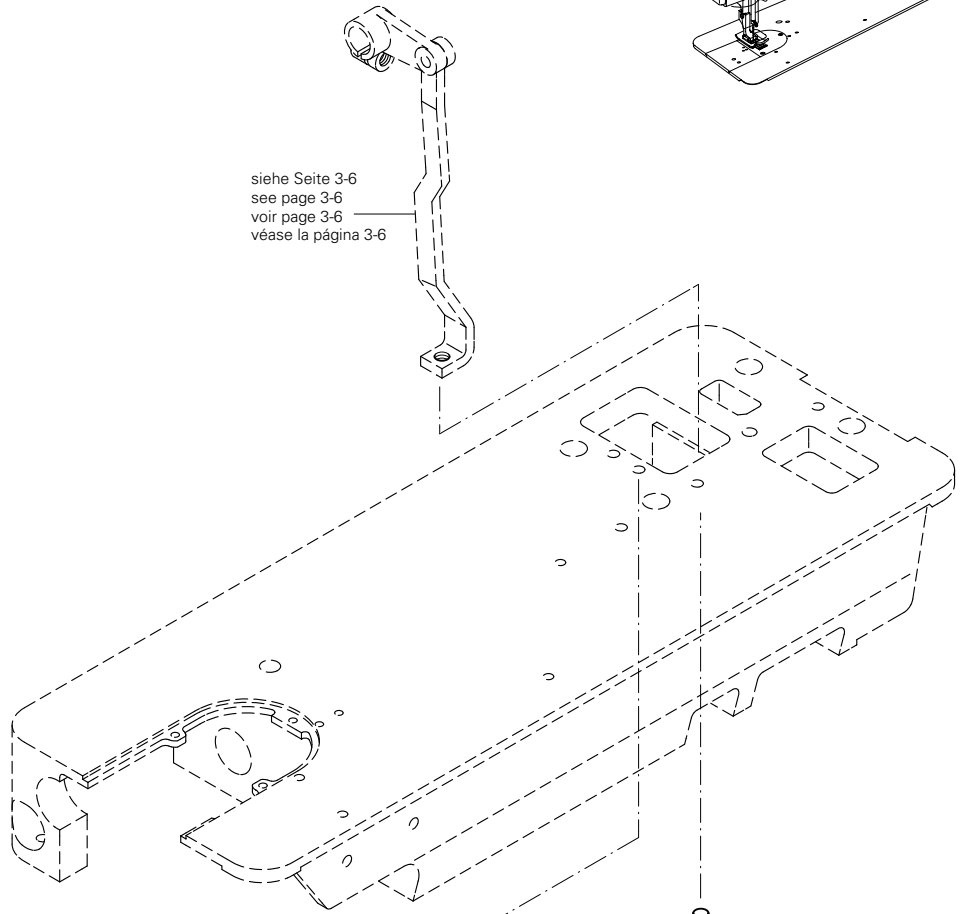

91-168 377-05

91-168 370-71/951

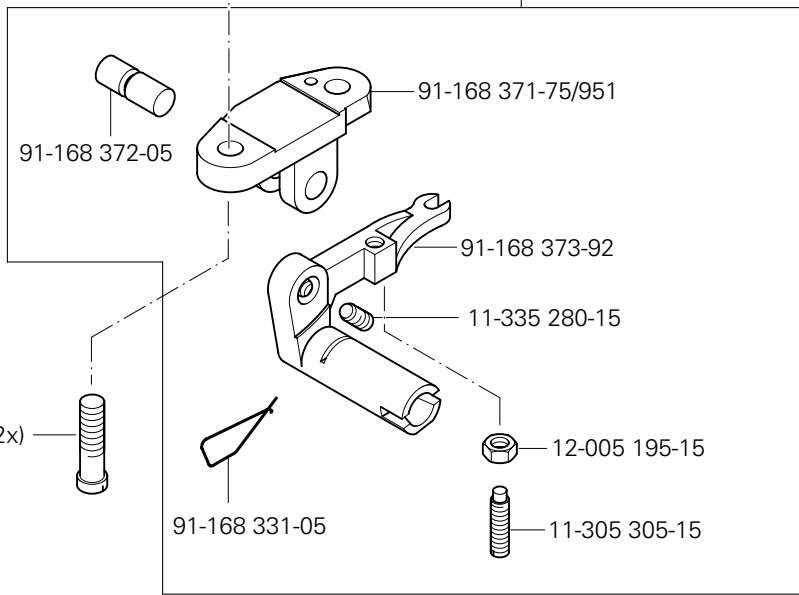

91-168 372-05

91-168 371-75/951

91-168 256-05

91-168 373-92

12-305 114-15

11-335 280-15

12-024 151-25 (2x)

11-174 378-15 (2x)

12-005 195-15

91-168 331-05

11-305 305-15

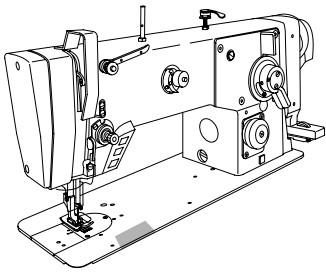

Grundplattenteile
 Bedplate parts
 Pièces du plateau fondamental
 Piezas del cárter

PFAFF 939-U

3.04

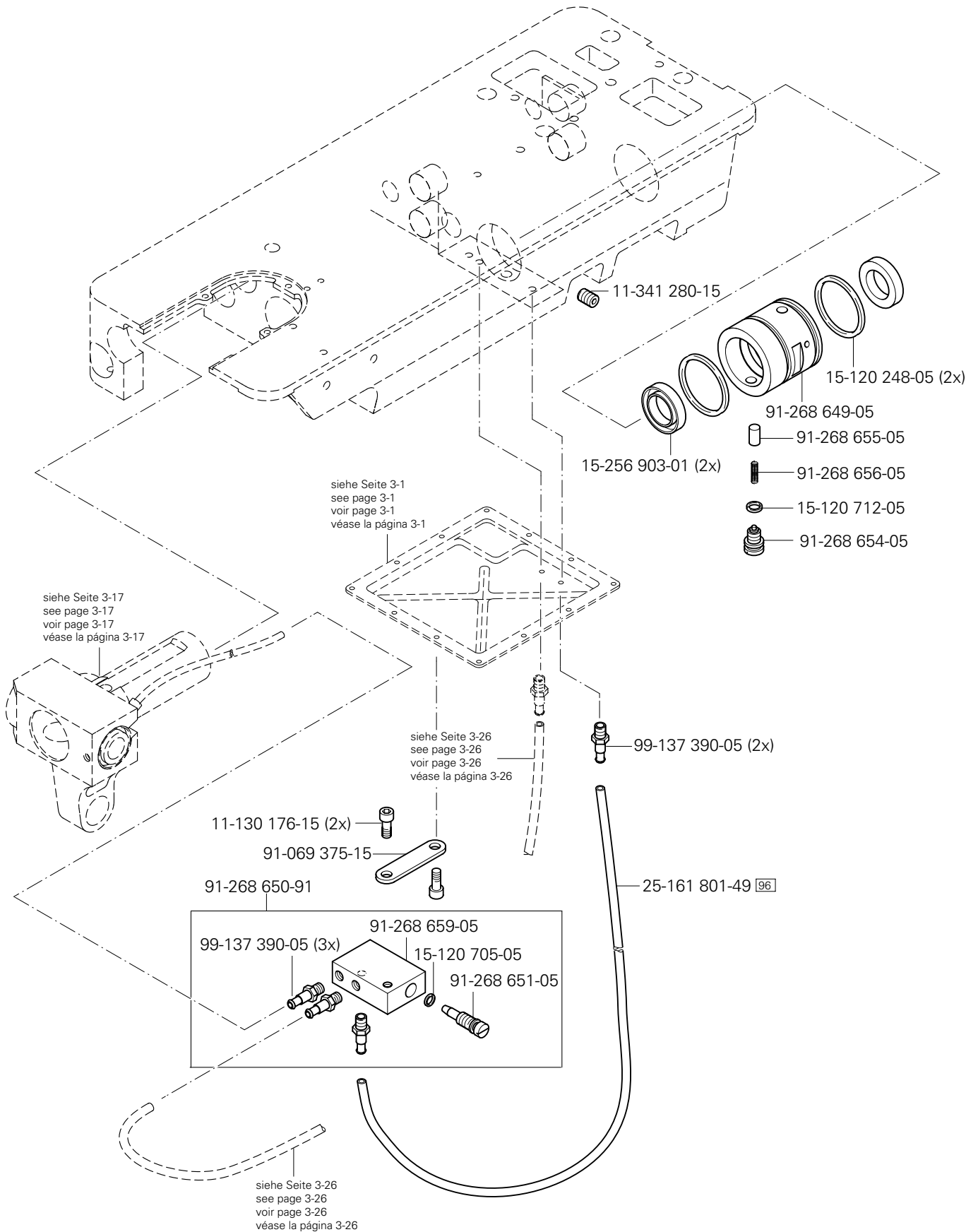

3.04

Grundplattenteile
 Bedplate parts
 Pièces du plateau fondamental
 Piezas del cárter

PFAFF 939-U

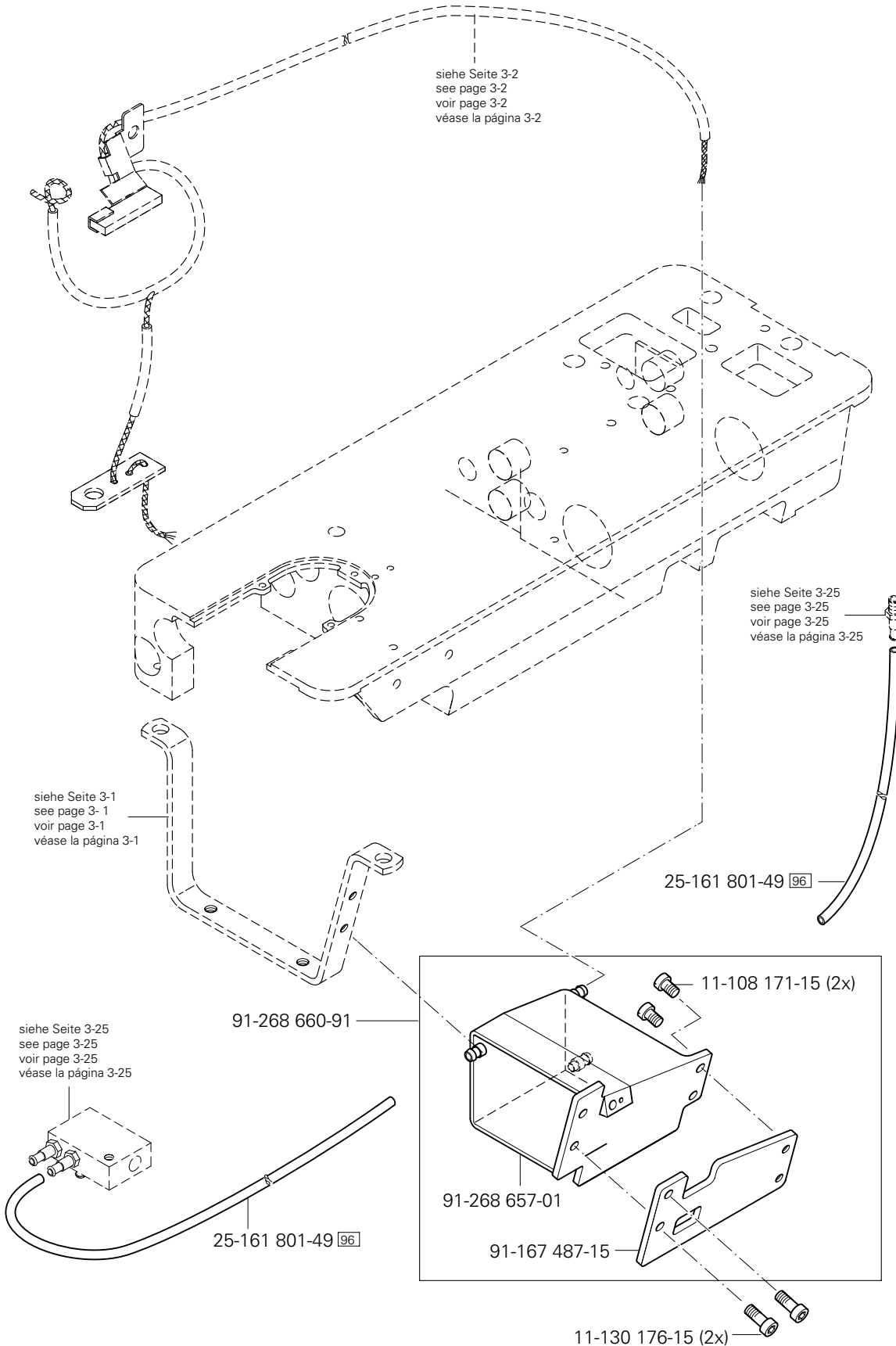
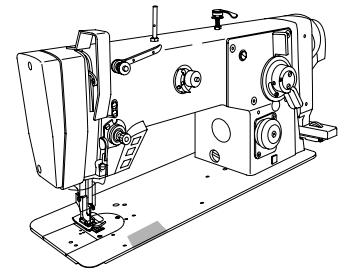

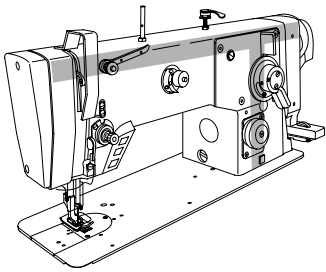

Fadenabschneid-Einrichtung (-900/24)
 Thread trimmer (-900/24)
 Coupe-fil (-900/24)
 Cortahilos (-900/24)

PFAFF 939-U

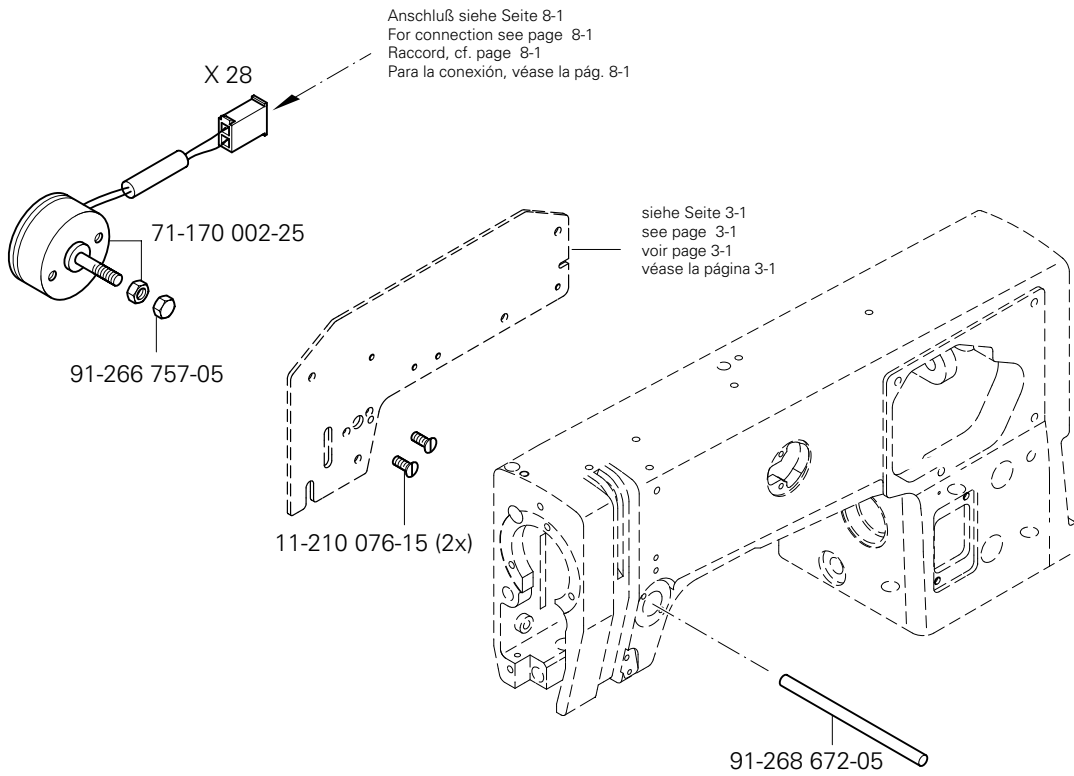

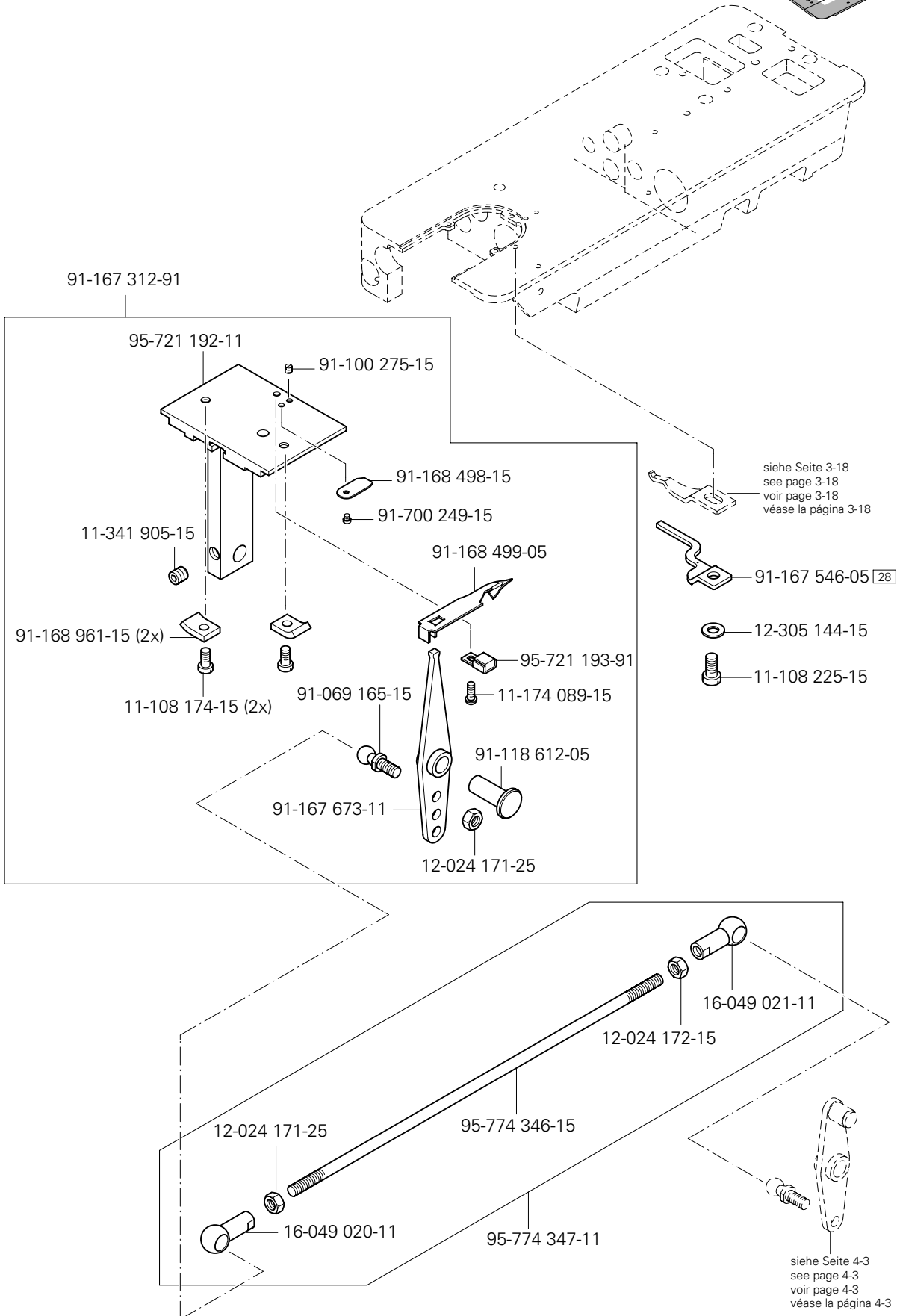
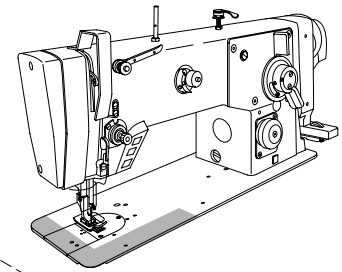

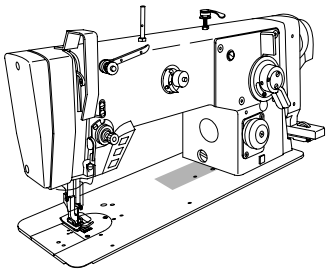

Fadenabschneid-Einrichtung (-900/24)
 Thread trimmer (-900/24)
 Coupe-fil (-900/24)
 Cortahilos (-900/24)

PFAFF 939-U

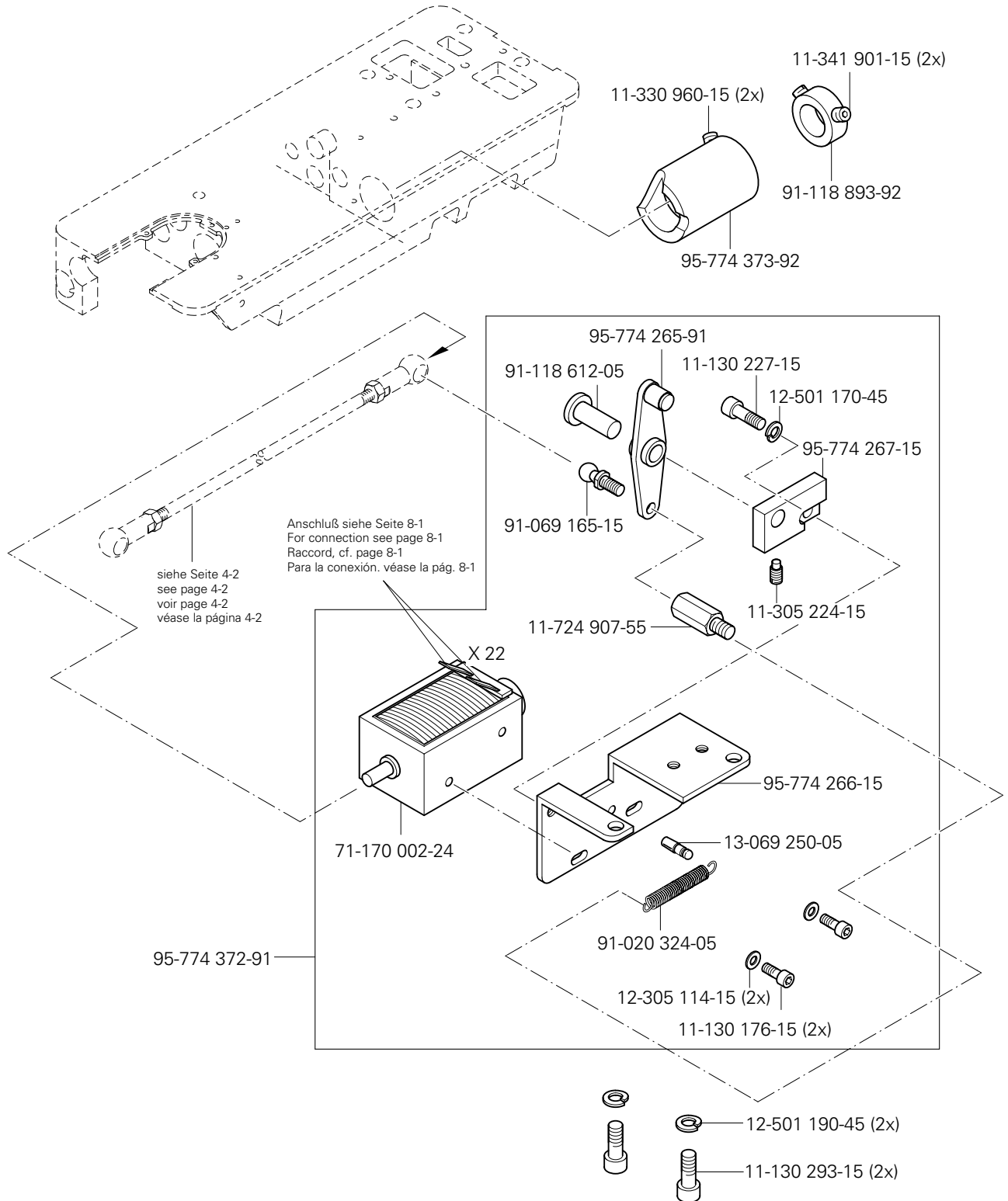

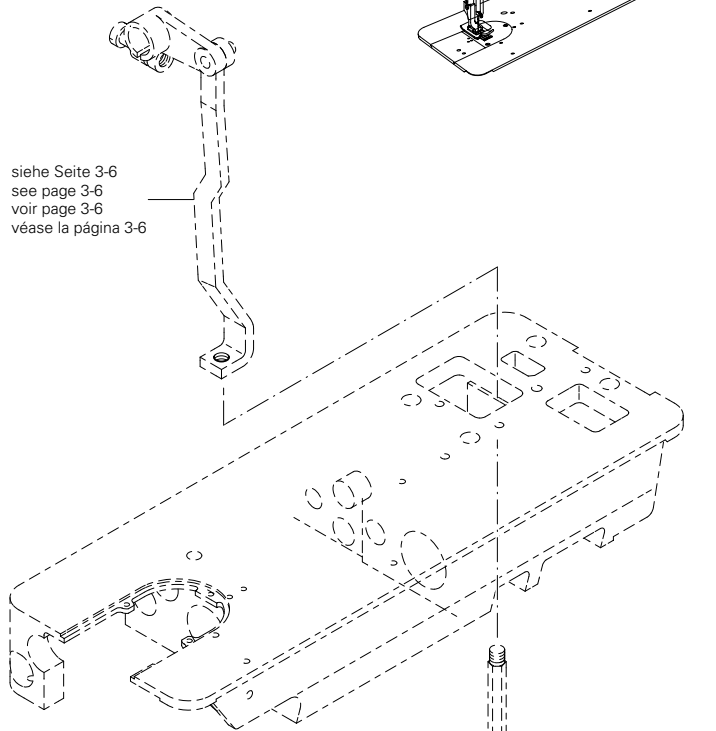
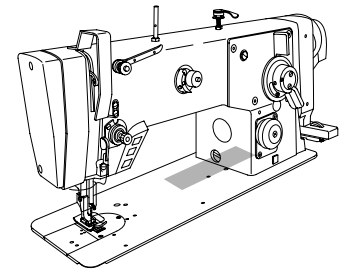

siehe Seite 3-24
 see page 3-24
 voir page 3-24
 véase la página 3-24

91-165 951-91
 für 3704 siehe Seite 15-8
 for 3704 see page 15-8
 pour 3704 voir page 15-8
 para 3704 véase la página 15-8

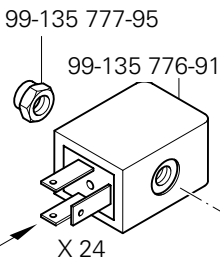
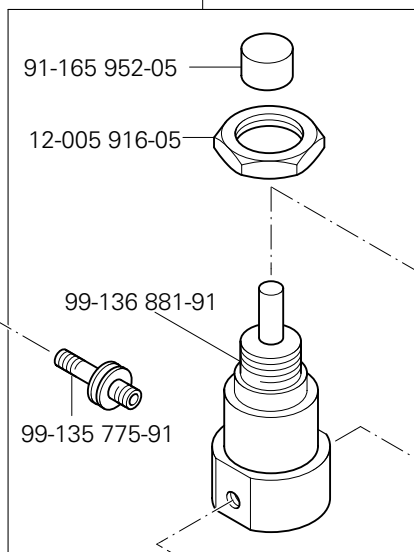

Anschluß siehe Seite 8-1
 For connection see page 8-1
 Raccord, cf. page 8-1
 Para la conexión, véase la pág. 8-1

Anschluß siehe Seite 6-2
 For connection see page 6-2
 Raccord, cf. page 6-2
 Para la conexión, véase la pág. 6-2

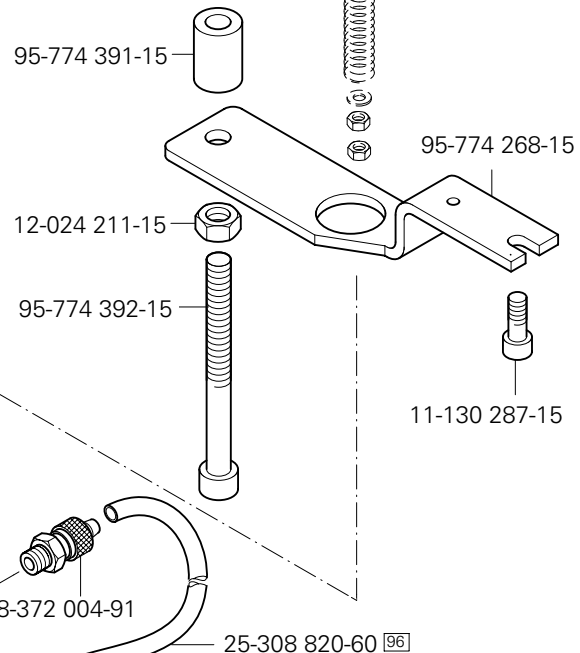
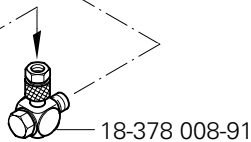

Zur Wartungseinheit
 For conditioning unit
 Pour la conditionneur d'air comprimé
 Para las require grupo acondicionador del aire

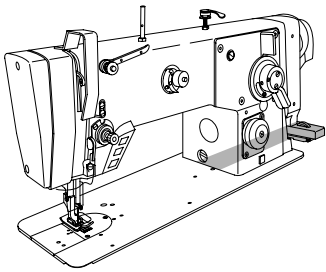

Verriegelungseinrichtung (-911/35)
 Backtacking mechanism (-911/35)
 Dispositif à points d'arrêt (-911/35)
 Rematador (-911/35)

PFAFF 939-U

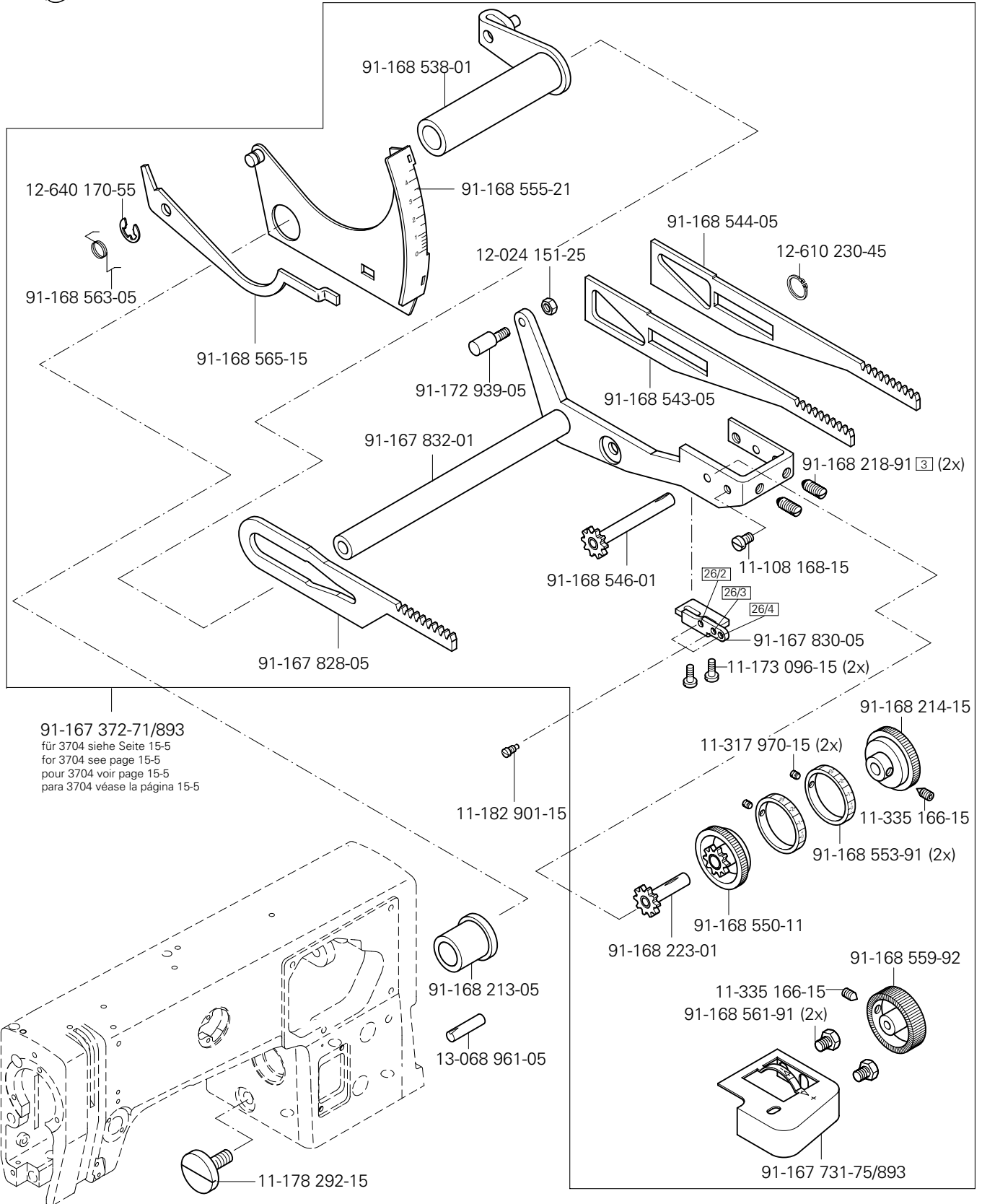

6

Verriegelungseinrichtung (-911/35)
 Backtacking mechanism (-911/35)
 Dispositif à points d'arrêt (-911/35)
 Rematador (-911/35)

PFAFF 939-U

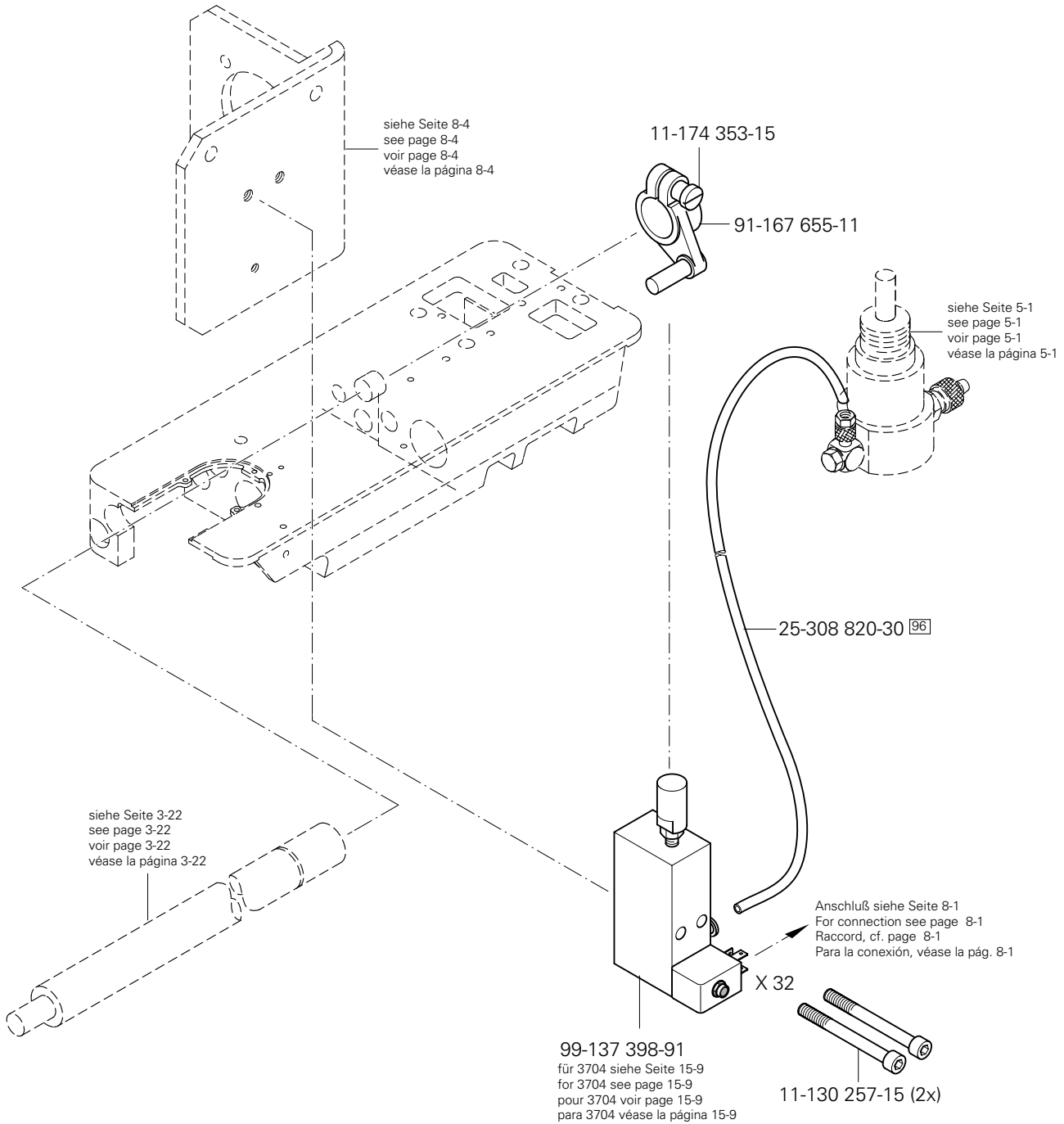
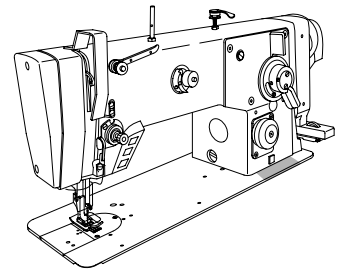

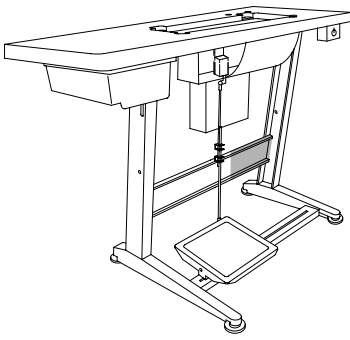

Wartungseinheit (-925/03)

Air filter / lubricator (-925/03)

Conditionneur d'air comprimé (-925/03)

Grupo acondicionador del aire comprimido (-925/03)

PFAFF 939-U

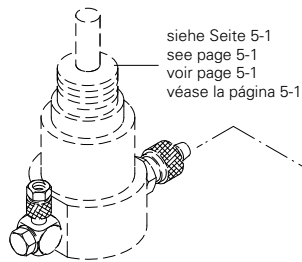

siehe Seite 5-1
see page 5-1
voir page 5-1
véase la página 5-1

25-308 820-60 [60] [96]

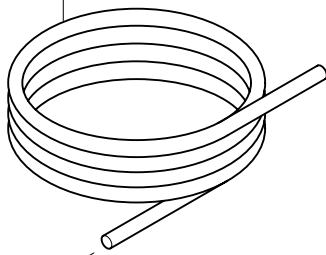

91-187 426-70/893

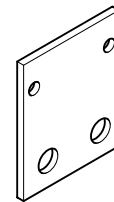

91-187 386-15

12-335 191-15 (2x)

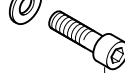

11-130 305-15 (2x)

99-136 546-91

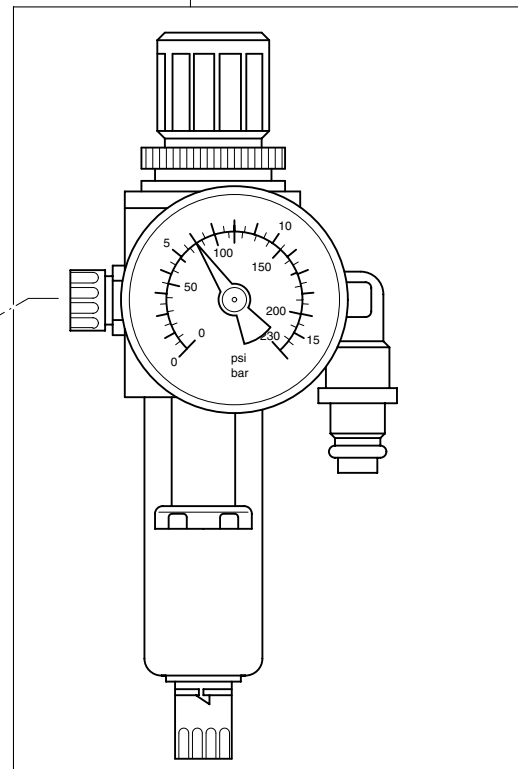

15-032 002-45



18-372 004-91 [60]

15-032 002-45



18-372 003-91 [60]

für 3704 siehe Seite 16-1 und 16-2
for 3704 see page 16-1 and 16-2
pour 3704 voir page 16-1 et 16-2
para 3704 véase la página 16-1 y 16-2

8.01

Kabelbaum zum Oberteil Cable tree to sewing head Faisceau de câbles vers la tête de machine Mazo de cables para el cabezal

PFAFF 939-U

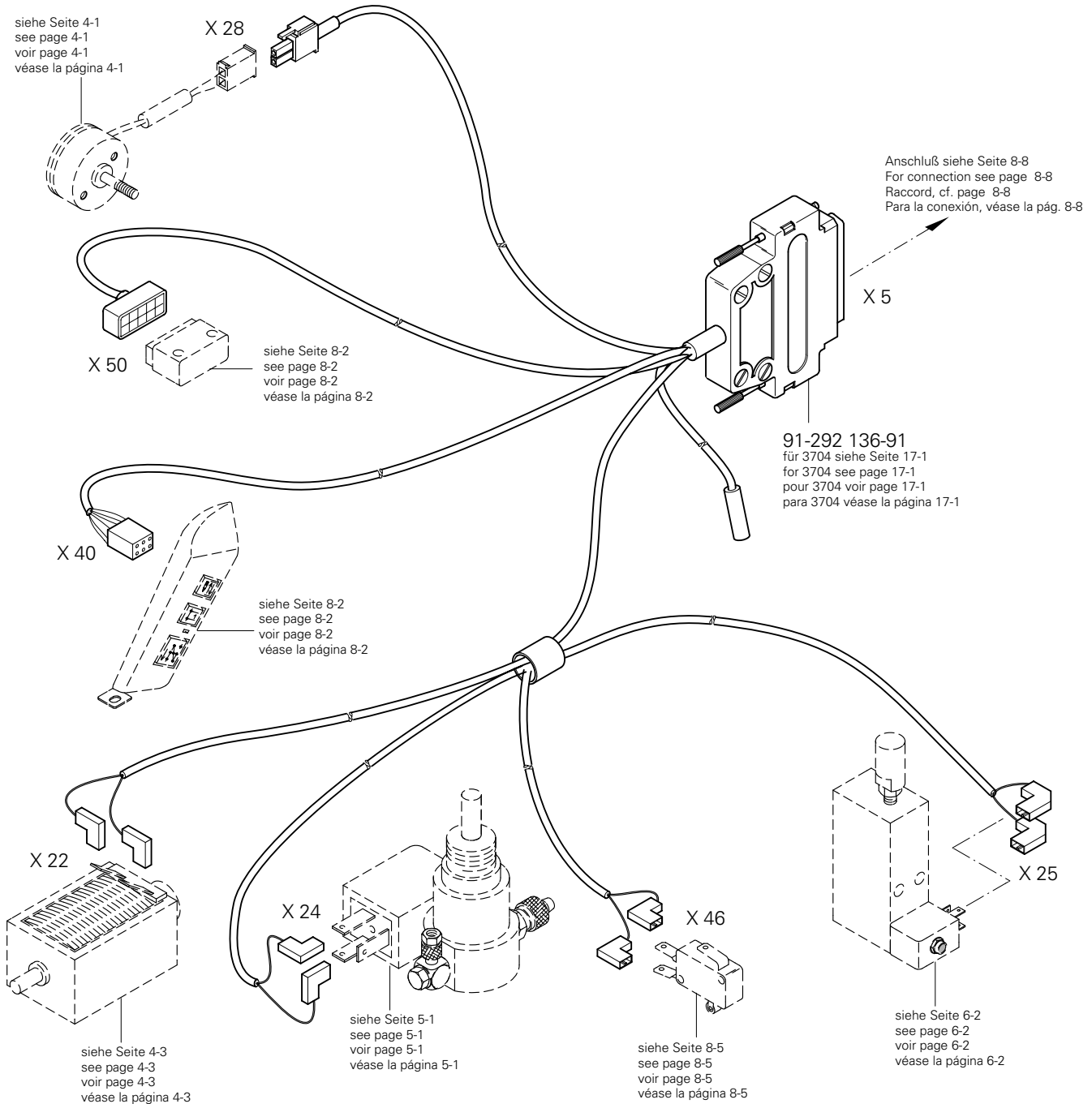
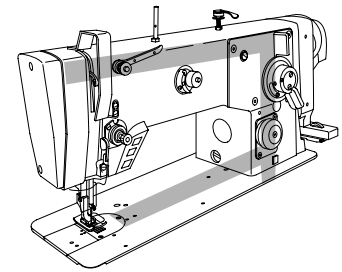

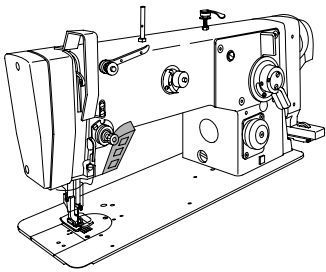

Tastschalter
 Push-button
 Interrupteur à bouton-poussoir
 Interruptor pulsador

PFAFF 939-U

8.02

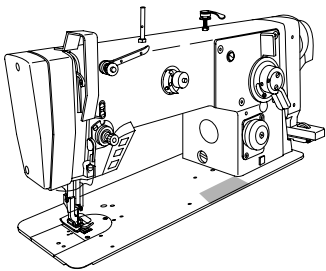
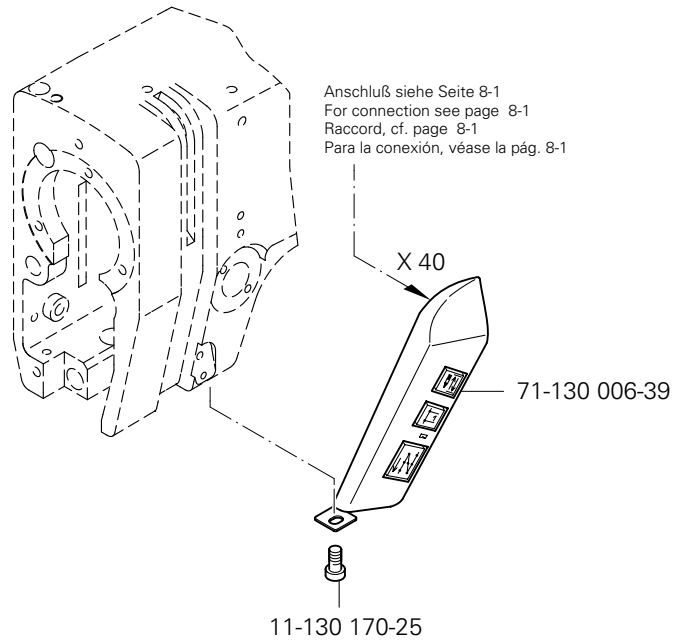

Oberteilerkennung
 Sewing head identification
 Detection de la tête
 Detección de la parte superior

PFAFF 939-U

8.03

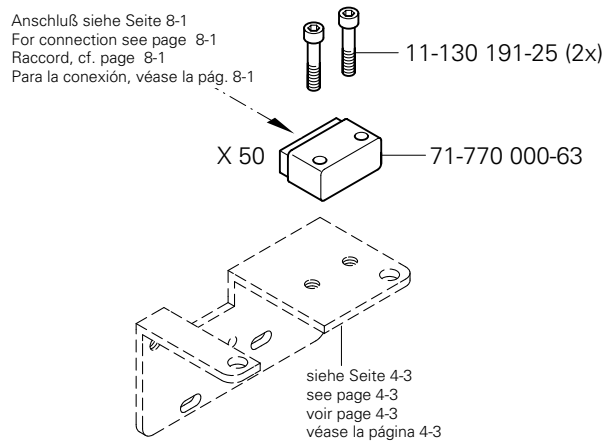

8.04

Bedienfeld
Control panel
Panneau de commande
Panel de mandos

PFAFF 939-U

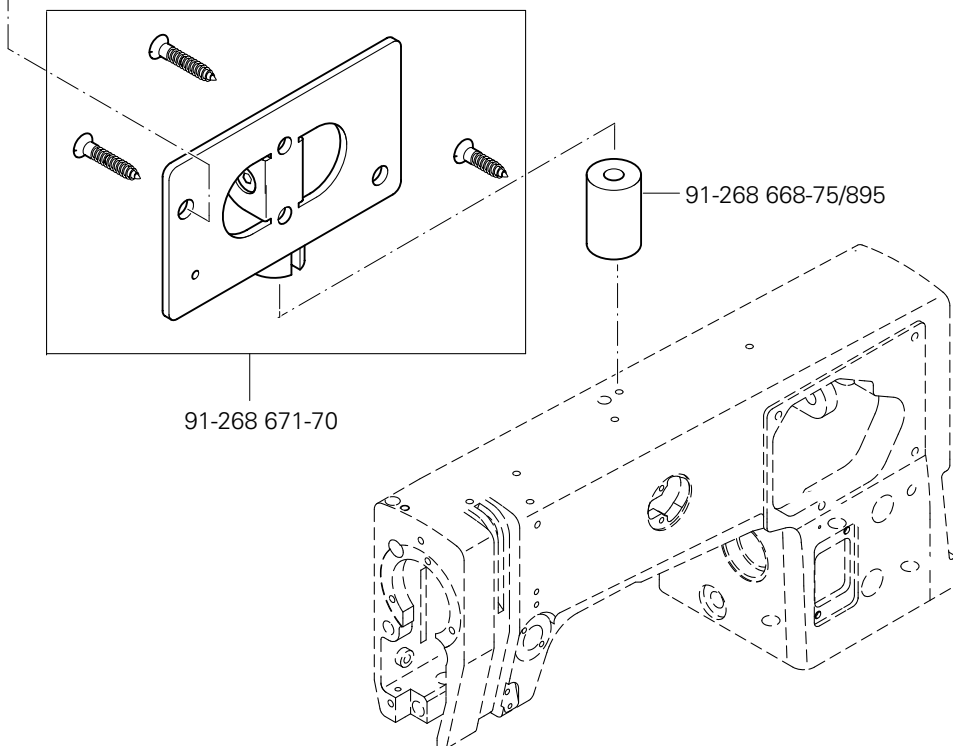
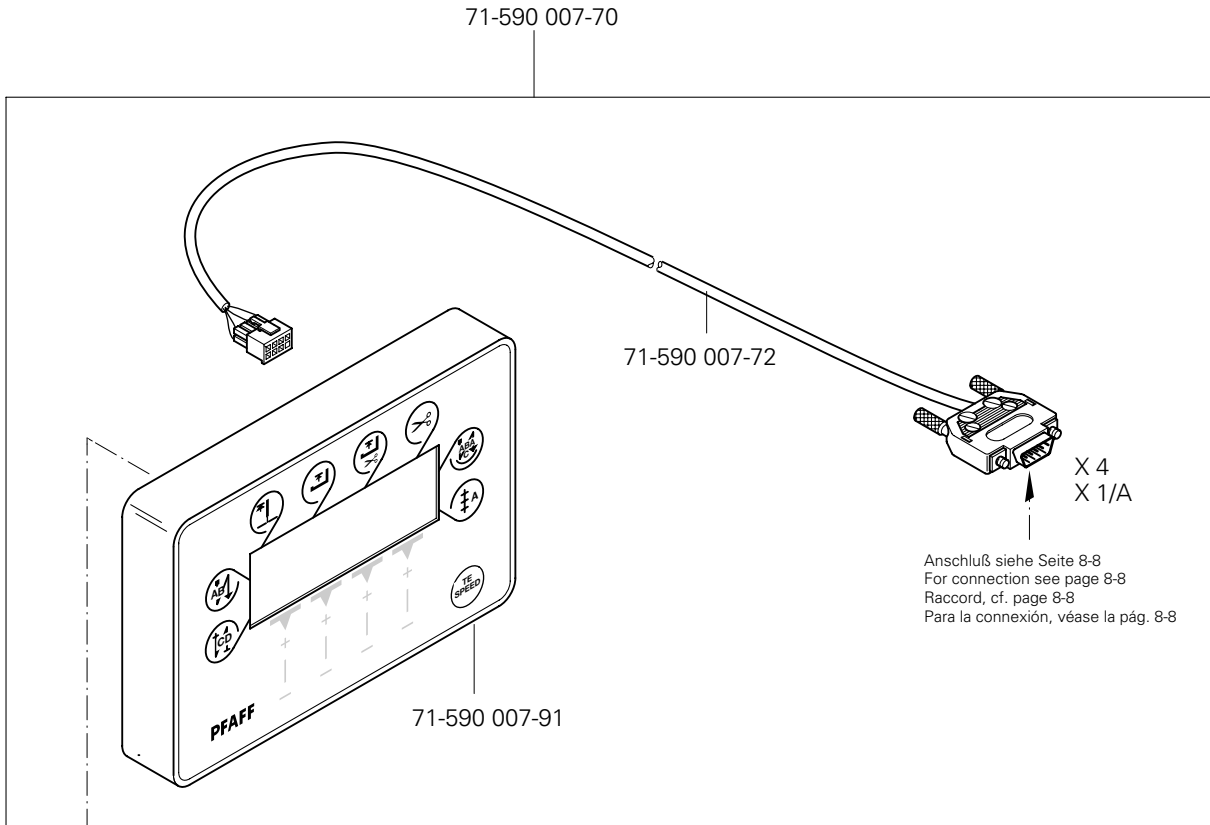
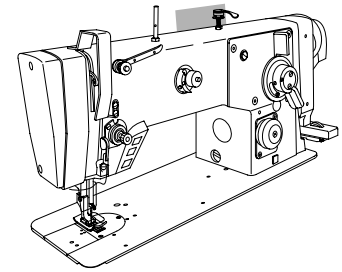

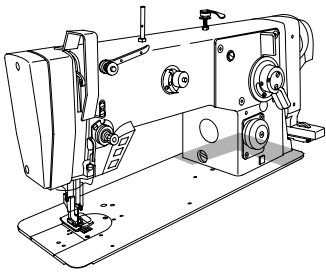

Einbaumotor
 Built-in motor
 Moteur incorporé
 Motor incorporado

PFAFF 939-U

8.05

71-523 555-63
 für 3704 siehe Seite 17-3
 for 3704 see page 17-3
 pour 3704 voir page 17-3
 para 3704 véase la página 17-3

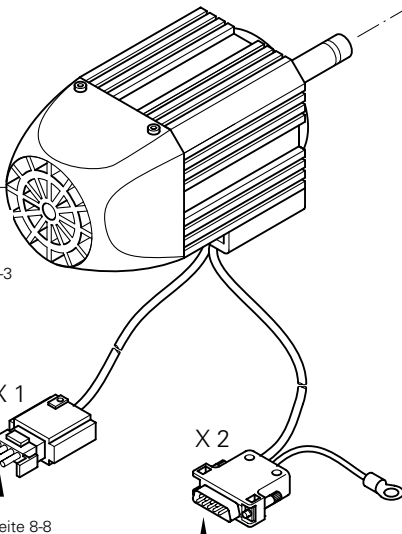

X 1
 Anschluß siehe Seite 8-8
 For connection see page 8-8
 Raccord, cf. page 8-8
 Para conexión, véase la pág. 8-8

X 2
 Anschluß siehe Seite 8-8
 For connection see page 8-8
 Raccord, cf. page 8-8
 Para conexión, véase la pág. 8-8

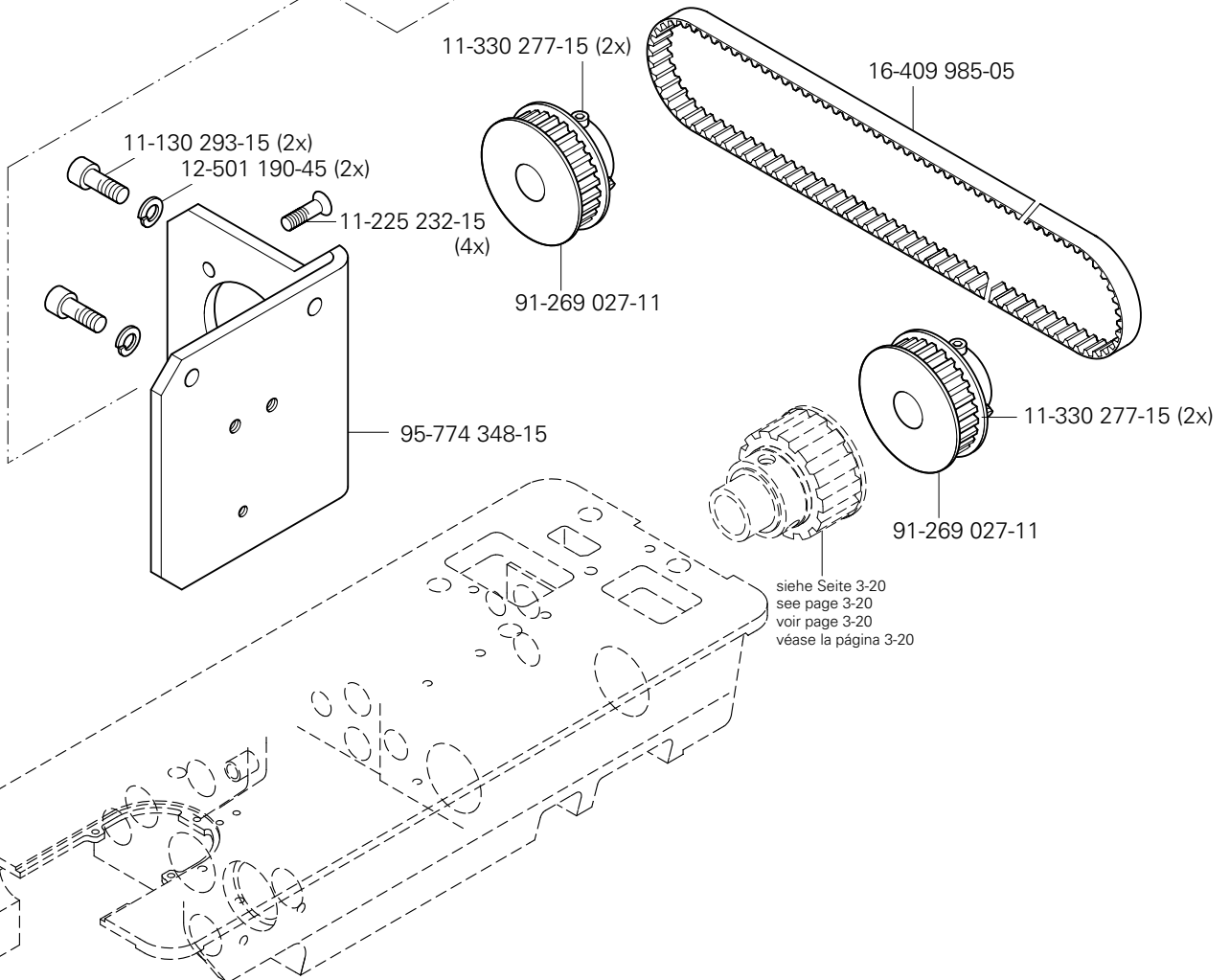

siehe Seite 3-20
 see page 3-20
 voir page 3-20
 véase la página 3-20

8.05

Einbaumotor
Built-in motor
Moteur incorporé
Motor incorporado

PFAFF 939-U

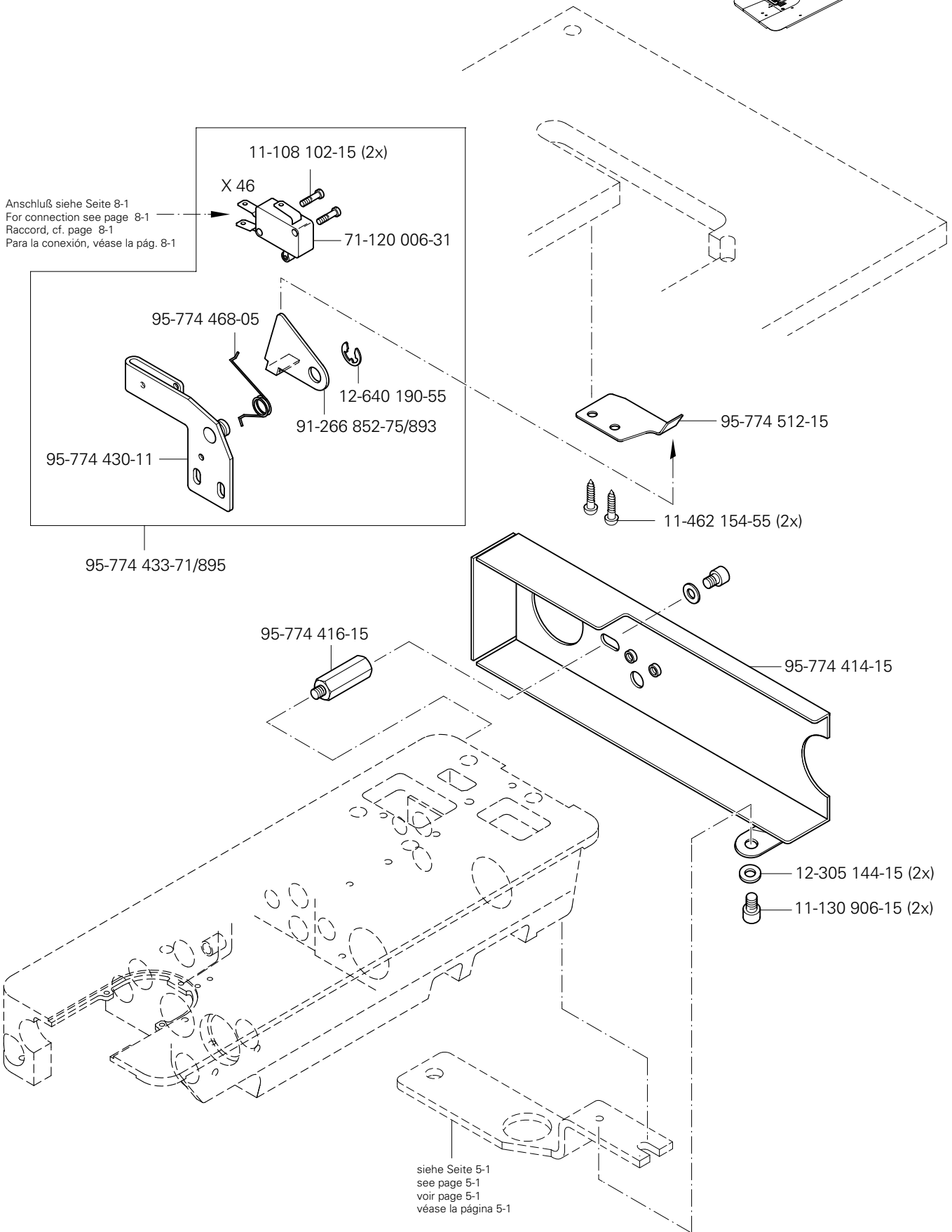
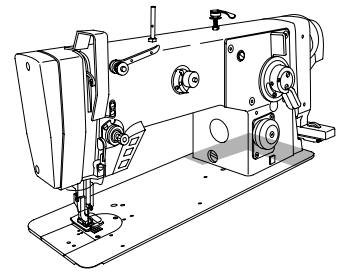

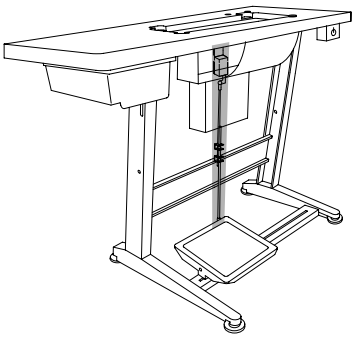

Sollwertgeber
Set-point generator
Codeur
Emisor del valor teórico

PFAFF 939-U

8.06

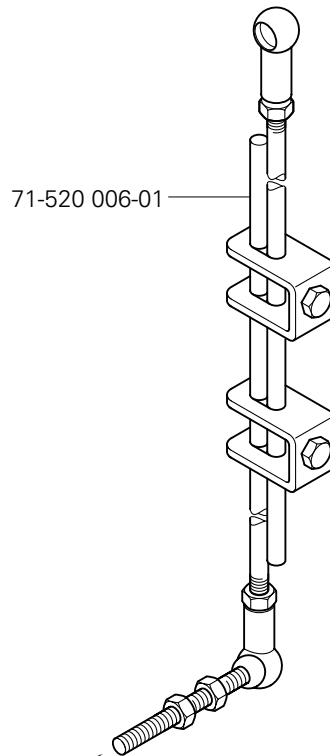
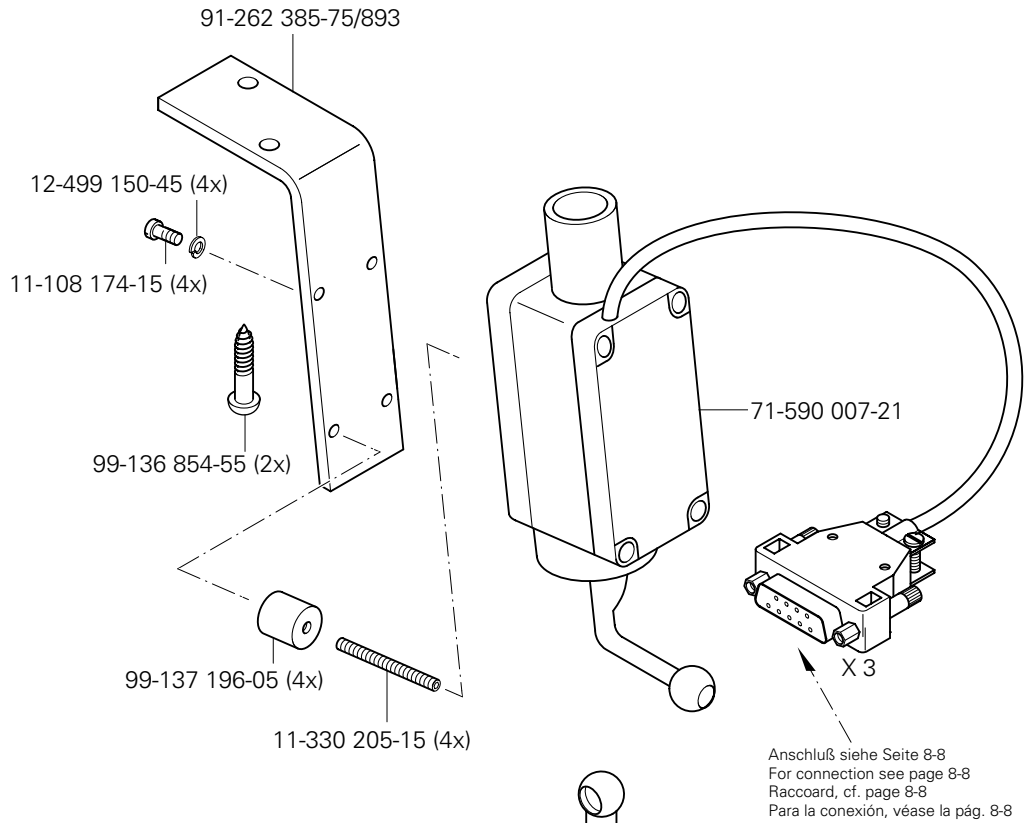

Zur Tretplatte
For the pedal
Pour la pédale
Para el pedal

8.07

Motor-Hauptschalter
Main switch
Interrupteur général
Interruptor principal

PFAFF 939-U

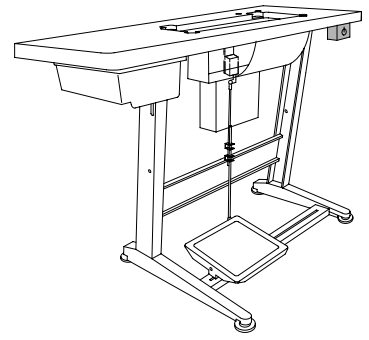

71-370 001-08



11-460 163-15

Anschluß siehe Seite 8-8
For connection see page 8-8
Raccord, cf. page 8-8
Para la conexión, véase la pág. 8-8

91-229 180-90 90/1

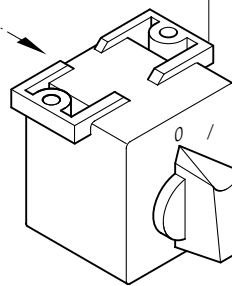

71-370 002-92



11-462 250-15 (2x)



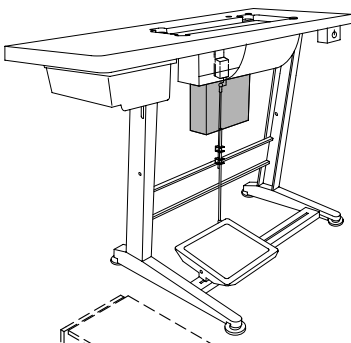

Steuerkasten
Control box
Boîte de contrôle
Caja de mandos

PFAFF 939-U

8.08

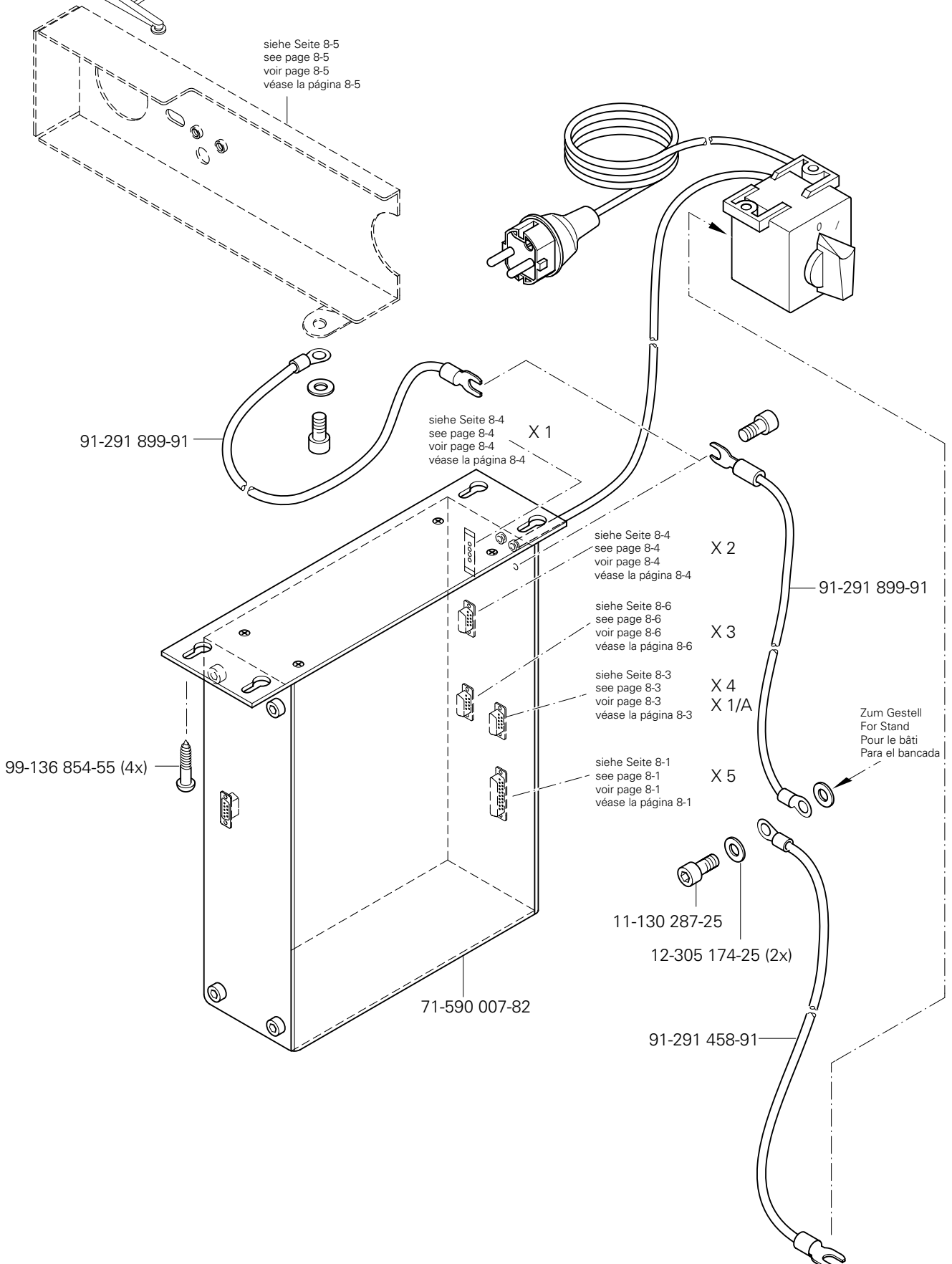

91-229 070-70/895

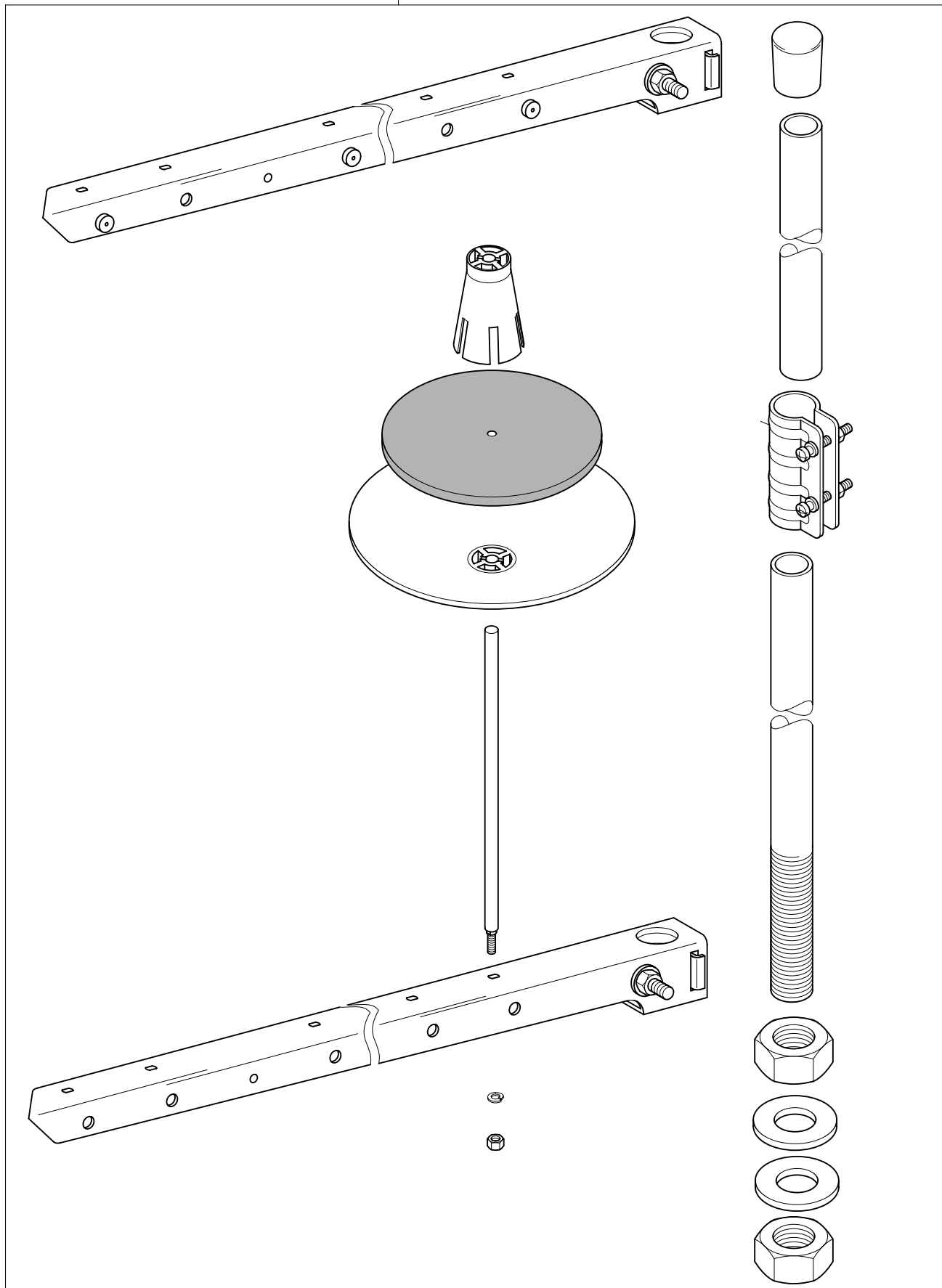

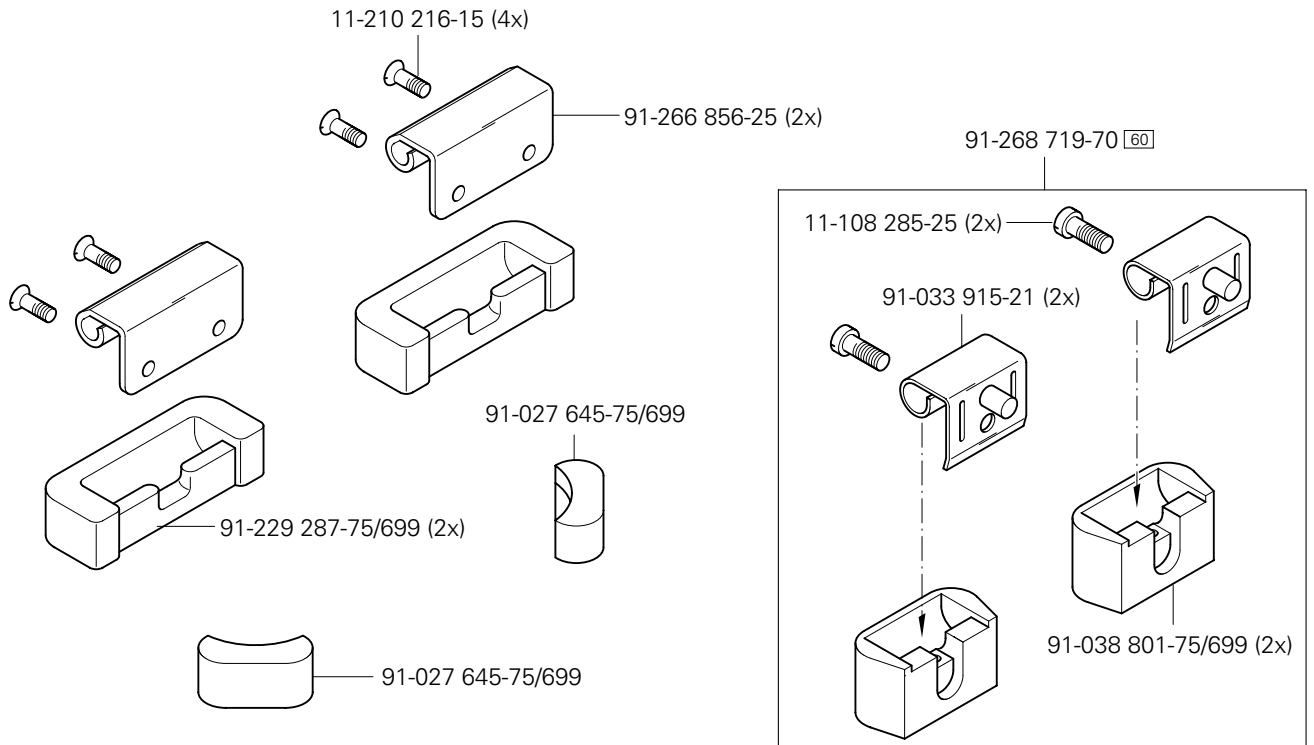
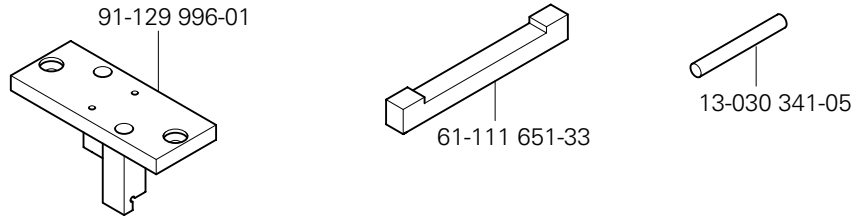

12

Knielüfterteile
 Knee lifter parts
 Pièces du releveur de genouillère
 Piezas del alzaprensatelas por rodillera

PFAFF 939-U

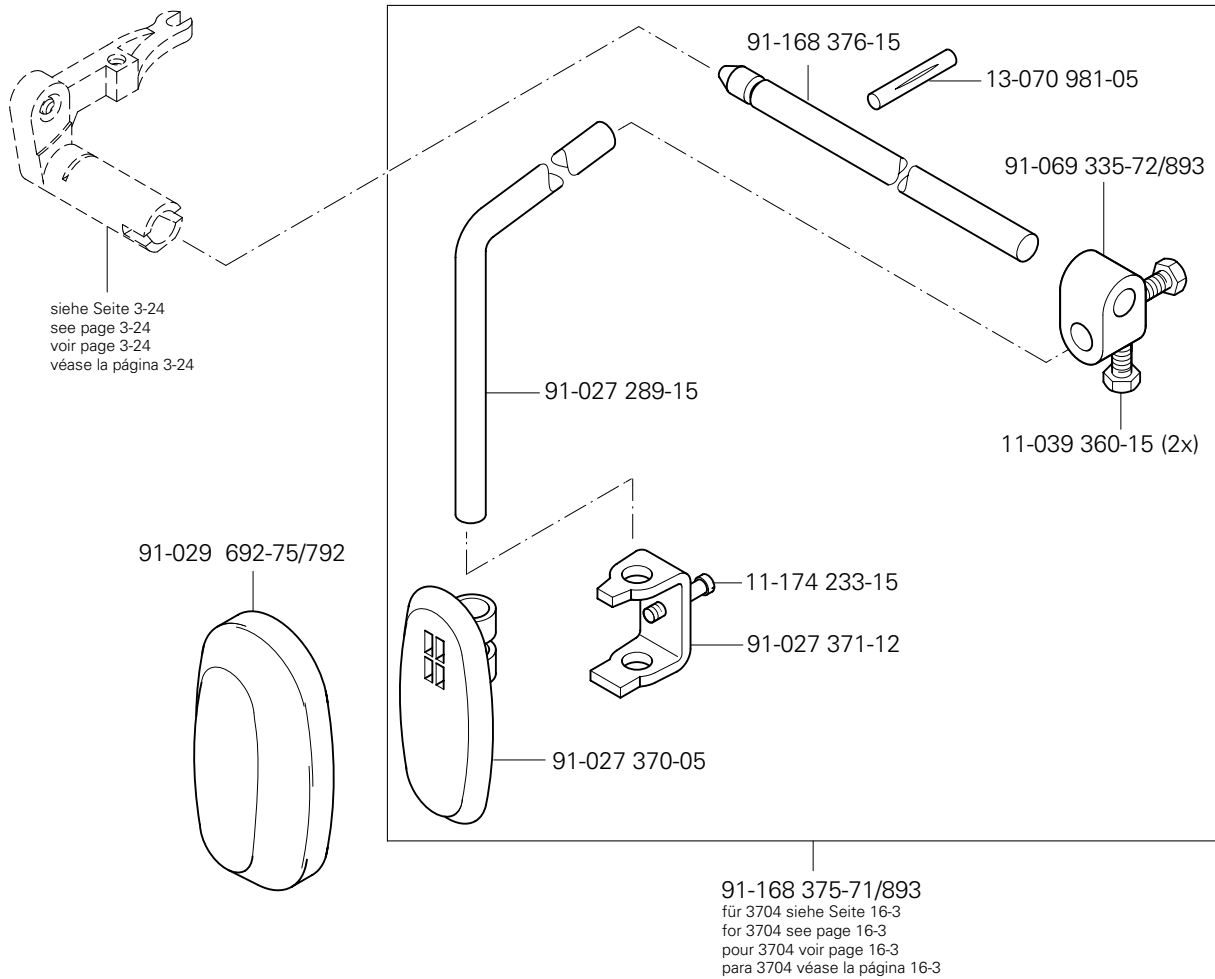

13

Keilriemen
 V-belt
 Courroie trapézoïdale
 Correa trapezoidal

PFAFF 939-U

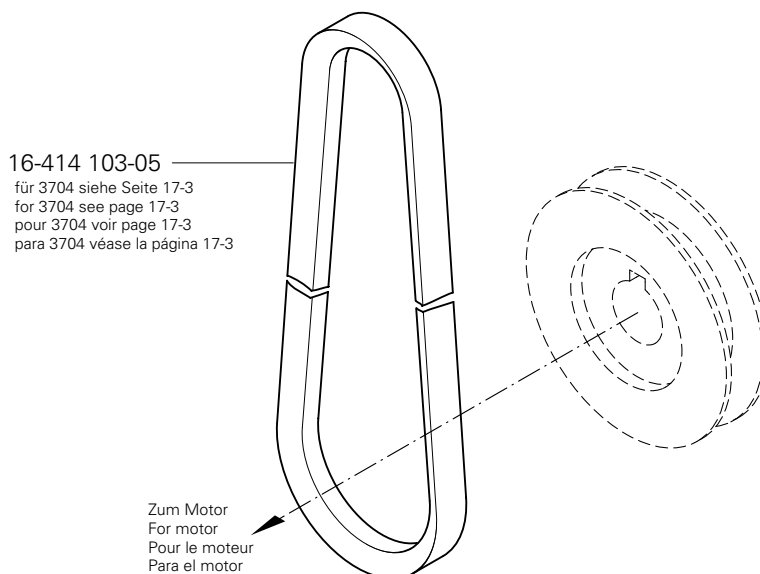

Öl Oil Huile Aceite	Mittelpunkts-Viskosität bei: Mean viscosity at: Viscosité moyenne à: Viscosidad media a:		Dichte bei: Density of: Densité à: Densidad a:		Bestellnummer für Behälter mit: Part number for can with: Numéro de commande pour récipients avec: Número de pedido para recipientes con:		
	°C	mm ² /s	°C	g/cm ³ (g/ml)	1 Liter 1 Litre 1 Litro	5 Liter 5 Litre 5 Litros	10 Liter 10 Litre 10 Litros
28-011 201-05	40	10,0	15	0,847	91-027 975-91	91-027 976-91	91-027 977-91
28-011 201-46	40	68,0	15	0,881	91-229 403-91 (140 ml)		

Fett Grease Graisse Grasa	Penetration Penetration Pénétration Penetración	Tropfpunkt Drip-point Point de suintement Punto de goteo	Bestellnummer für Behälter mit: Part number for can with: Numéro de commande pour récipients avec: Número de pedido para recipientes con:		
			mm/10	°C	0,25 kg
28-011 201-99	400-430	160			28-011 201-99
28-011 202-05					28-011 202-05
28-011 202-47	220-250	185			28-011 202-47

Reinigungsmittel Cleansing agent Agents de nettoyage Limpiadores	Bestellnummer für Behälter mit: Part number for can with: Numéro de commande pour récipients avec: Número de pedido para recipientes con:		
	240 ml		
Isoprophyl-Alkohol	95-665 735-91		

15.01

Gehäuseteile
Housing sections
Parties du corps
Piezas del cárter

PFAFF 3704

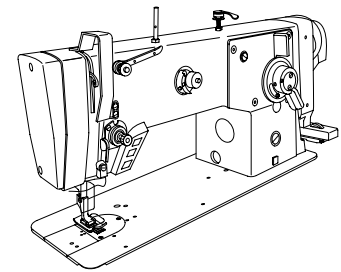

91-188 721-71/895

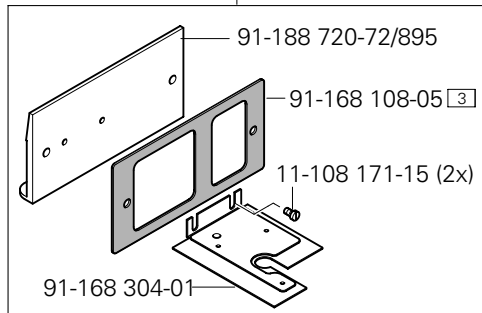

91-188 625-75/893

11-108 222-15 (2x)

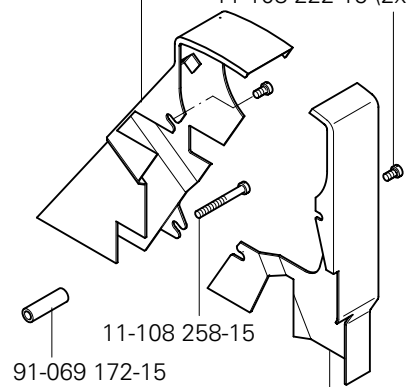

11-108 258-15

91-069 172-15

91-188 624-75/893

91-188 715-71/893

91-268 051-72/893

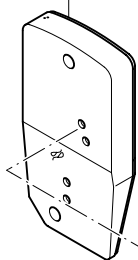

Anschluß siehe Seite 16-1 und 16-2
For connection see page 16-1 and 16-2
Raccord, cf. page 16-1 et 16-2
Para la conexión, véase la pág. 16-1 y 16-2

91-087 602-71/893

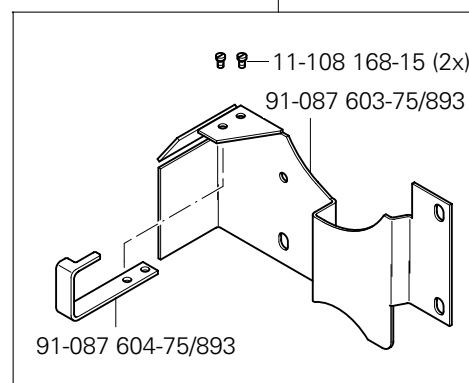

11-108 168-15 (2x)

91-087 603-75/893

91-087 604-75/893

11-108 222-15 (3x)

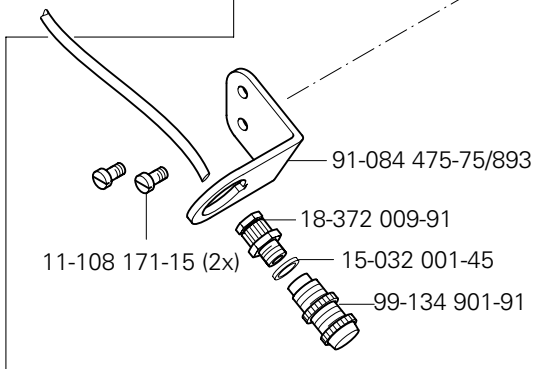

11-108 171-15 (2x)

91-084 475-75/893

18-372 009-91

15-032 001-45

99-134 901-91

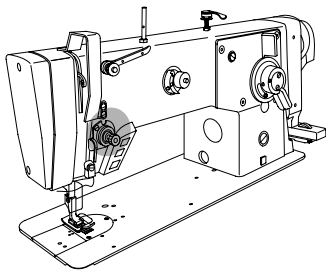

Kopfteile
Needle head parts
Pièces de tête
Piezas de la cabeza PFAFF 3704

15.02

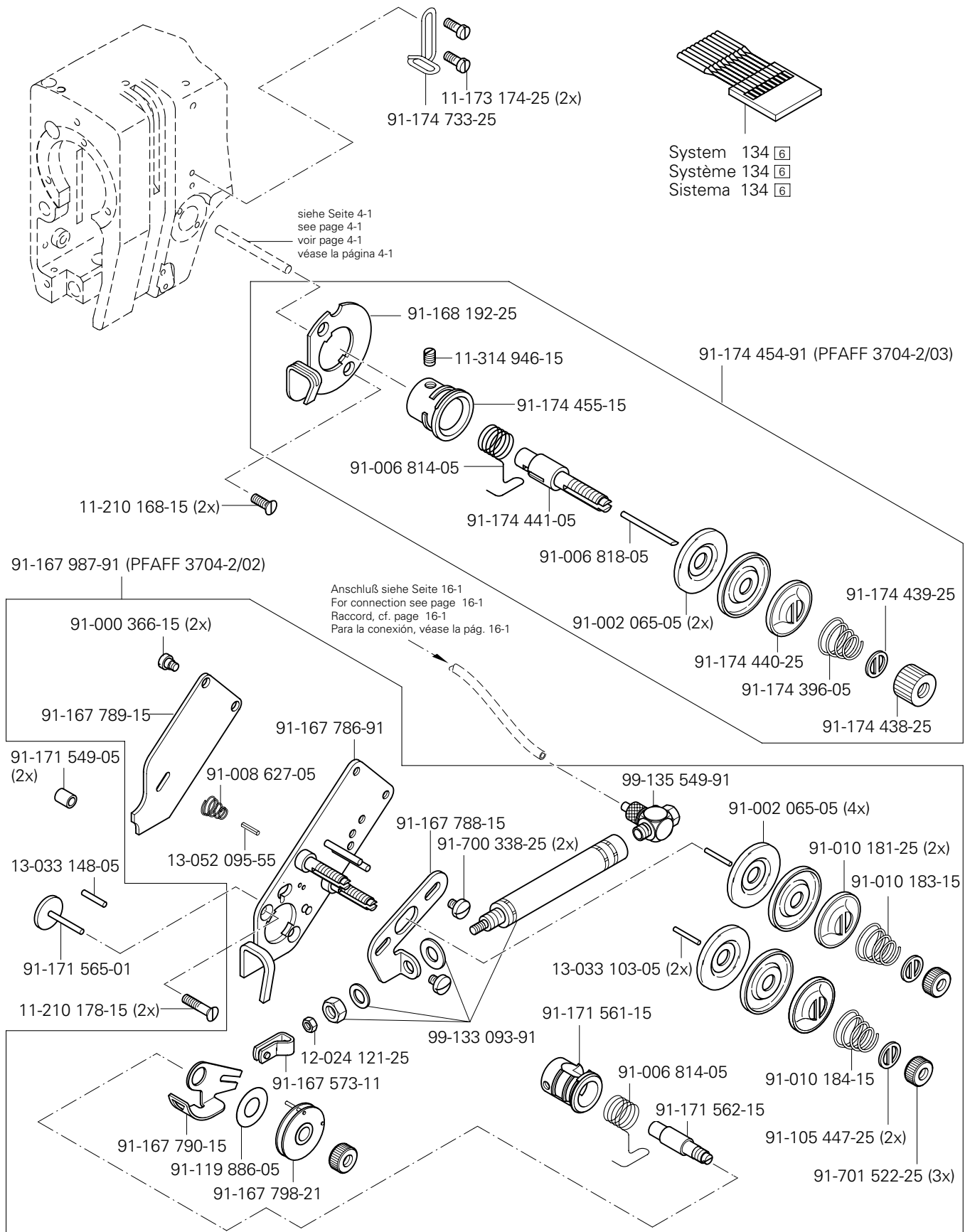

15.03

Armteile
Arm parts
Pièces de bras
Piezas del brazo

PFAFF 3704

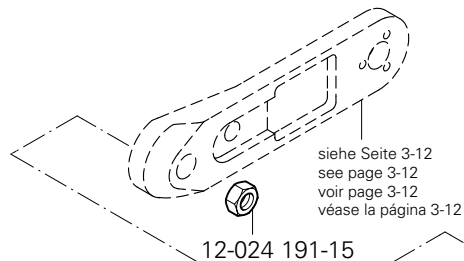
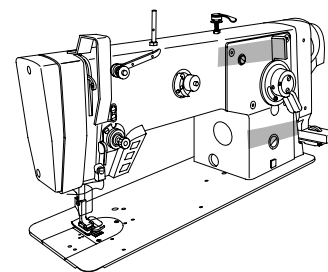

12-024 191-15

91-167 624-91 [11] = 6,0 mm

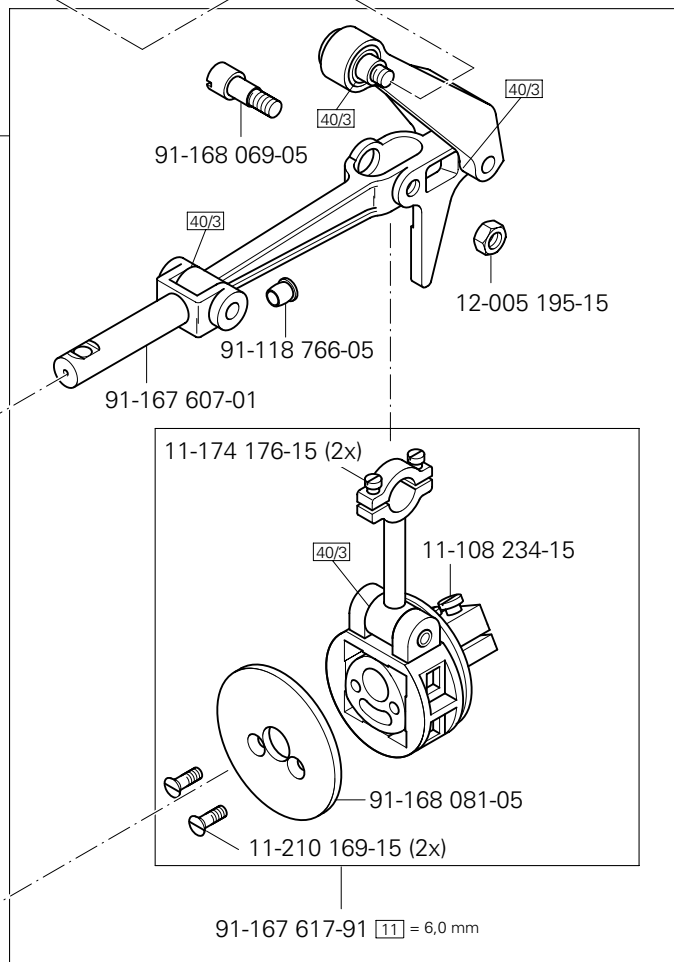

91-168 106-05

siehe Seite 3-4
see page 3-4
voir page 3-4
véase la página 3-4

12-305 174-15

12-024 191-15

siehe Seite 15-4
see page 15-4
voir page 15-4
véase la página 15-4

91-168 084-91

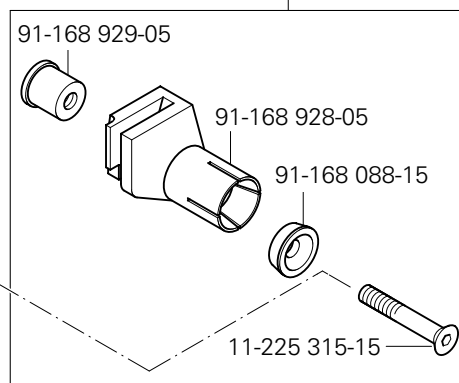

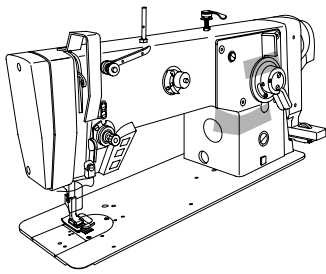

Armteile
 Arm parts
 Pièces de bras
 Piezas del brazo PFAFF 3704

15.03

siehe Seite 3-12
 see page 3-12
 voir page 3-12
 véase la página 3-12

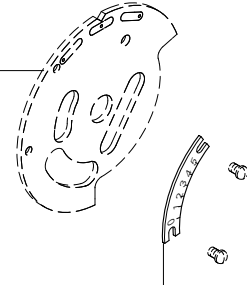

91-168 235-25 11 = 6,0 mm

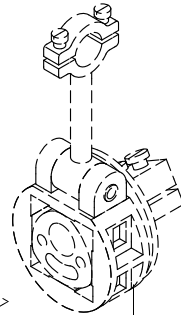
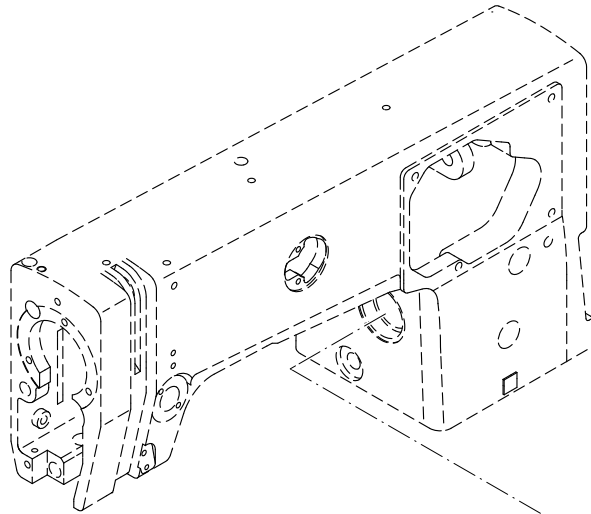

siehe Seite 15-3
 see page 15-3
 voir page 13-3
 véase la página 15-3

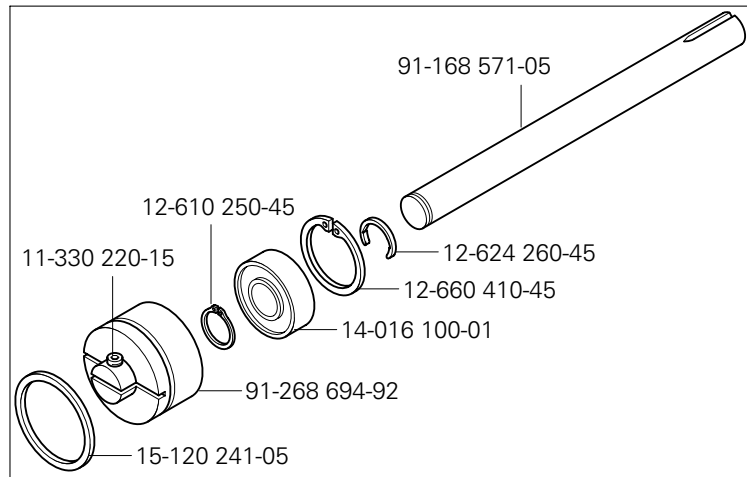

91-168 571-05

12-610 250-45

11-330 220-15

12-624 260-45

12-660 410-45

14-016 100-01

91-268 694-92

15-120 241-05

91-268 693-91

siehe Seite 3-1
 see page 3-1
 voir page 3-1
 véase la página 3-1

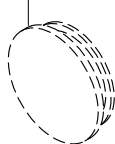

15.03

Armteile
 Arm parts
 Pièces de bras
 Piezas del brazo

PFAFF 3704

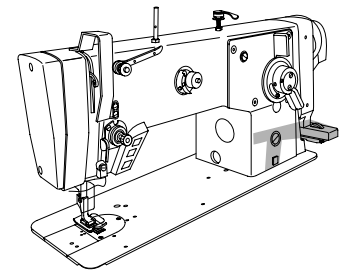

91-167 587-71/893

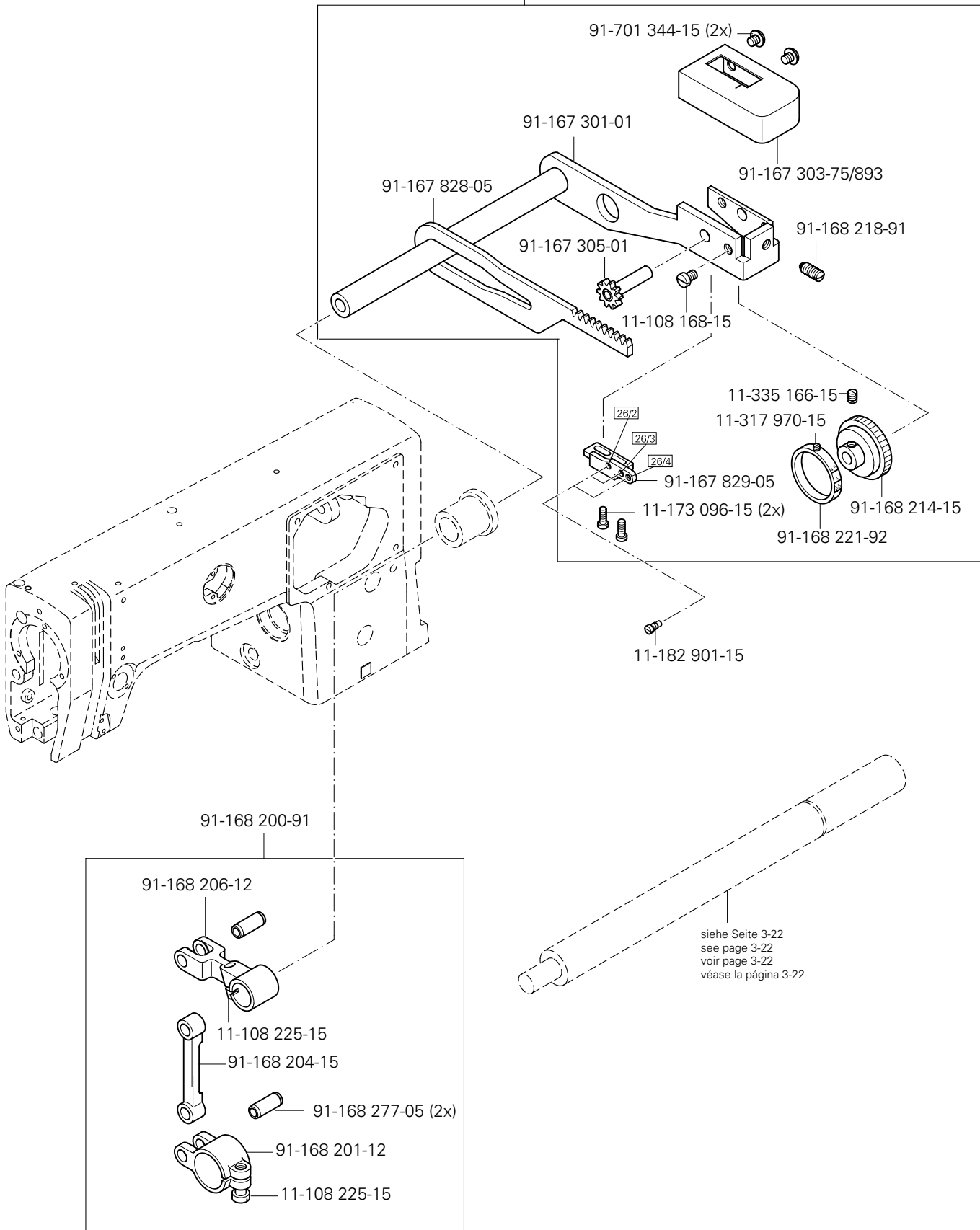

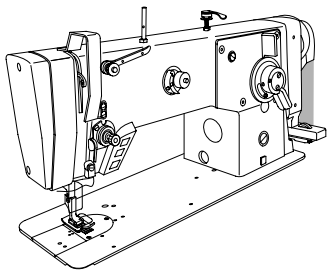

Armteile
 Arm parts
 Pièces de bras
 Piezas del brazo PFAFF 3704

15.03

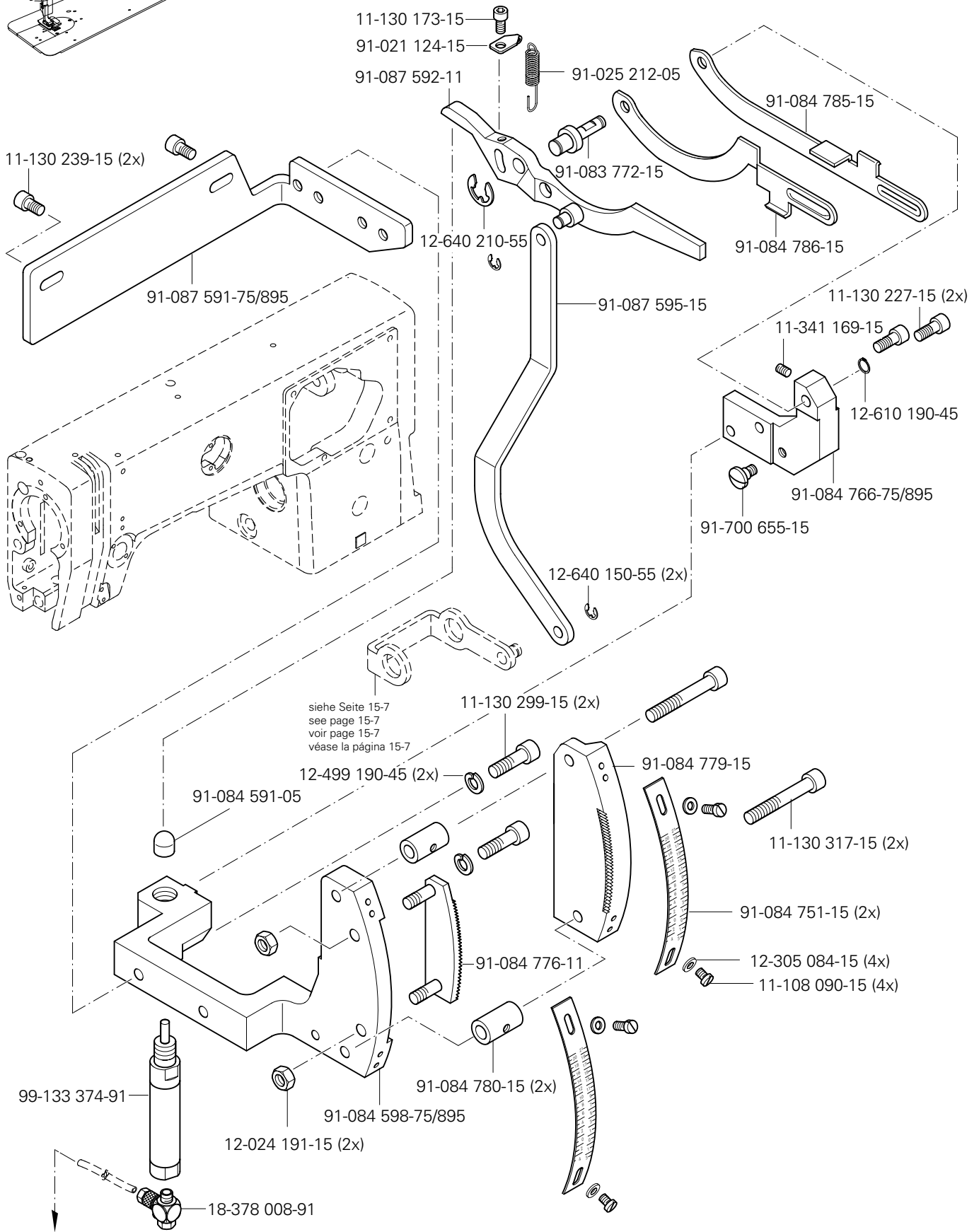

Anschluß siehe Seite 16-1 und 16-2
 For connection see page 16-1 and 16-2
 Raccord, cf. page 16-1 et 16-2
 Para la conexión, véase la pág. 16-1 y 16-2

15.04

Grundplattenteile
Bedplate parts
Pièces du plateau fondamental
Piezas del cárter

PFAFF 3704

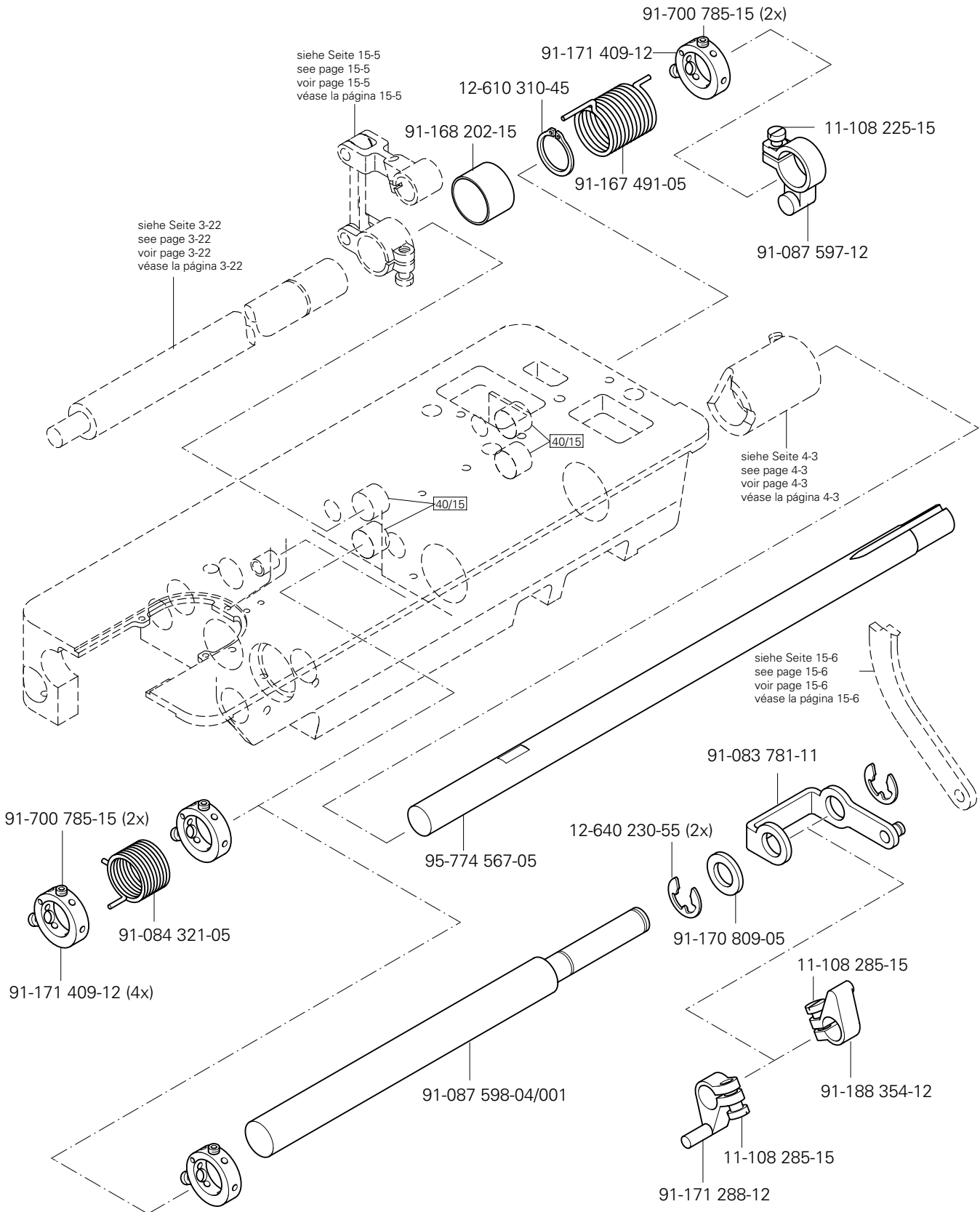
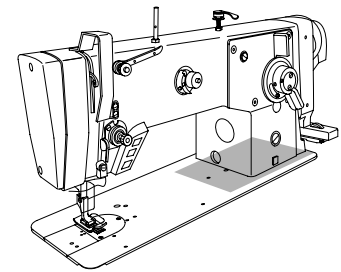

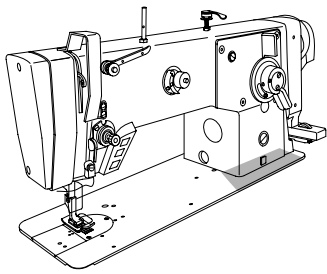

Grundplattenteile
Bedplate parts
Pièces du plateau fondamental
Piezas del cárter

PFAFF 3704

15.04

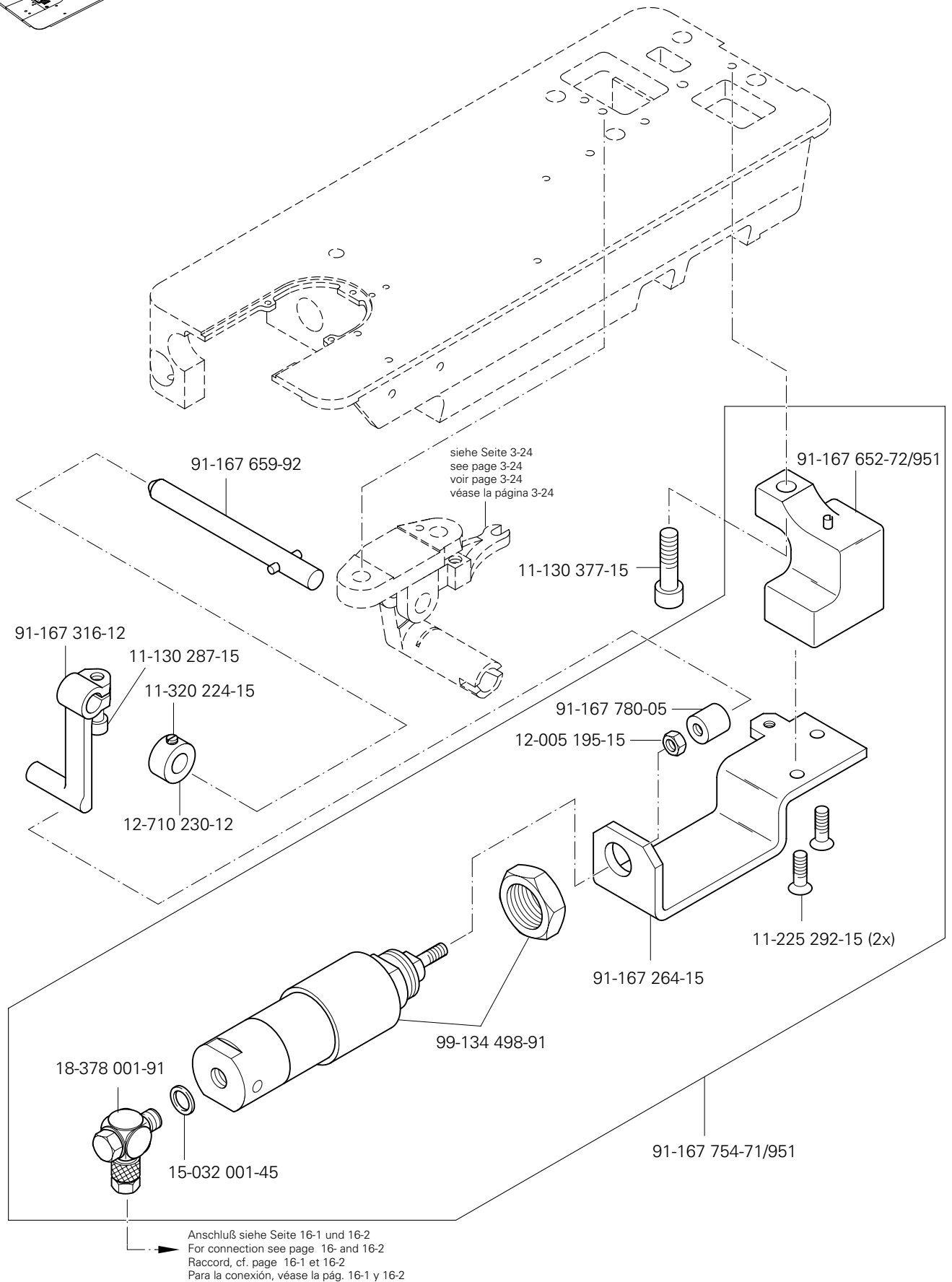

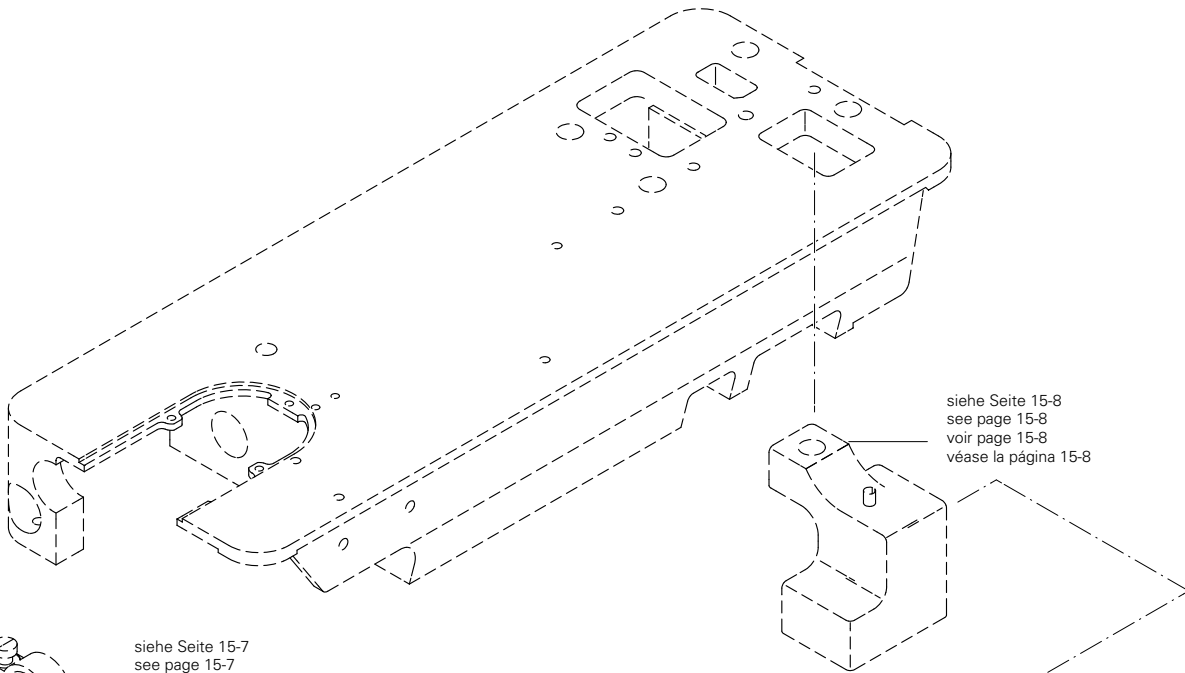
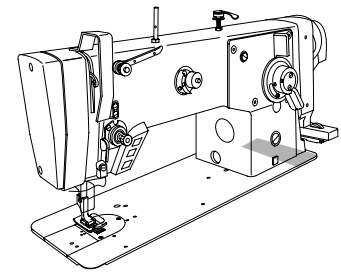

siehe Seite 15-8
see page 15-8
voir page 15-8
véase la página 15-8

siehe Seite 15-7
see page 15-7
voir page 15-7
véase la página 15-7

91-088 027-91

12-024 191-15 (2x)

11-130 287-15 (2x)

91-084 474-05 (2x)

siehe Seite 15-7
see page 15-7
voir page 15-7
véase la página 15-7

91-087 596-15

99-134 886-91 (2x)

Anschluß siehe Seite 16-1 und 16-2
For connection see page 16-1 and 16-2
Raccord, cf. page 16-1 et 16-2
Para la conexión, véase la pág. 16-1 y 16-2

Anschluß siehe Seite 16-1 und 16-2
For connection see page 16-1 and 16-2
Raccord, cf. page 16-1 et 16-2
Para la conexión, véase la pág. 16-1 y 16-2

15-032 001-45 (2x)

18-378 008-91 (2x)

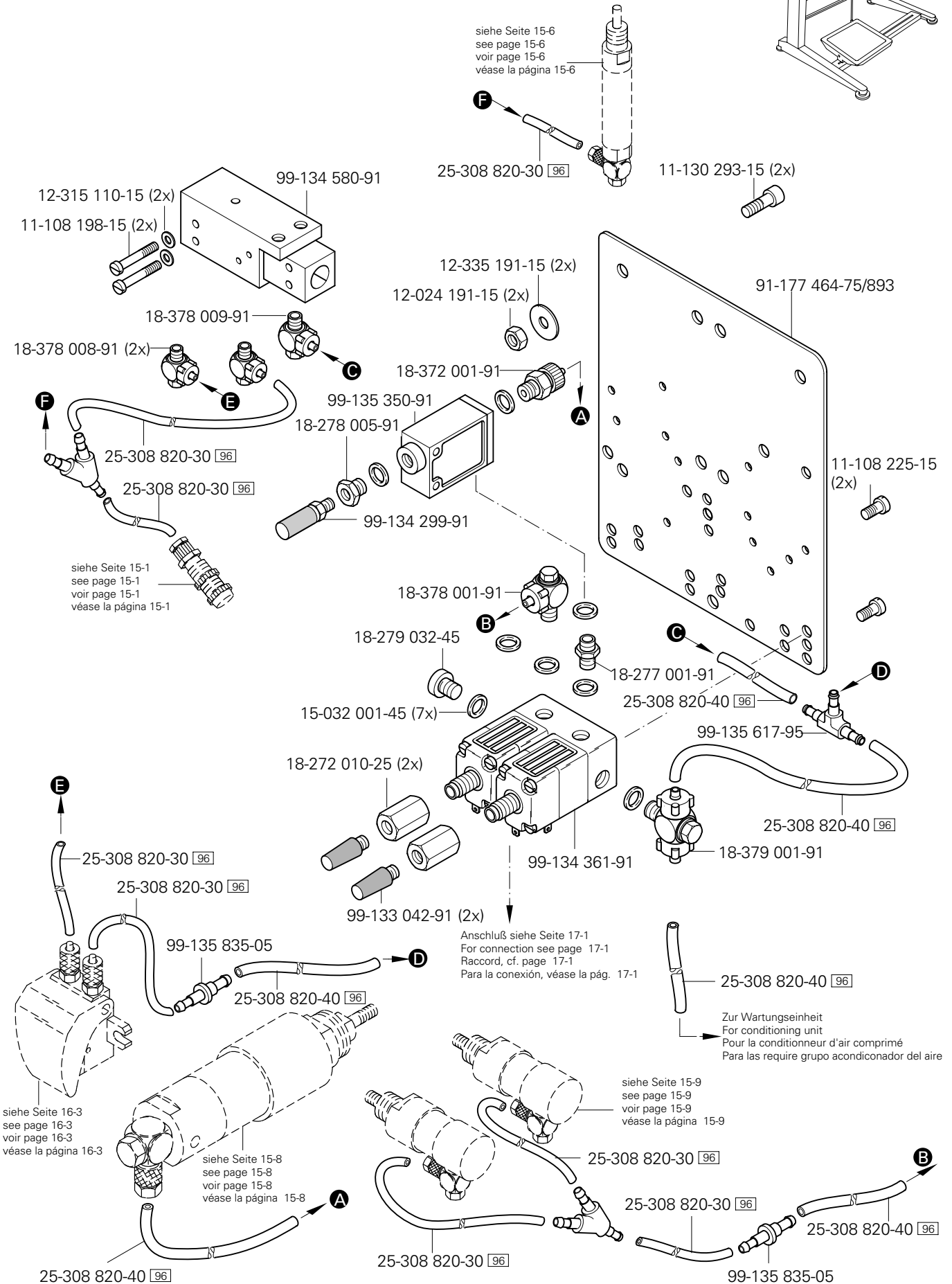
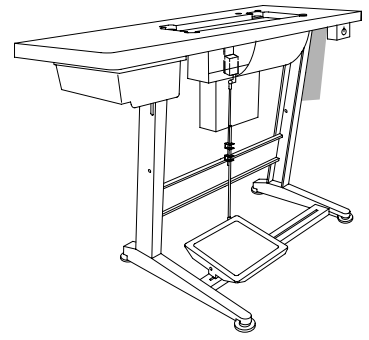

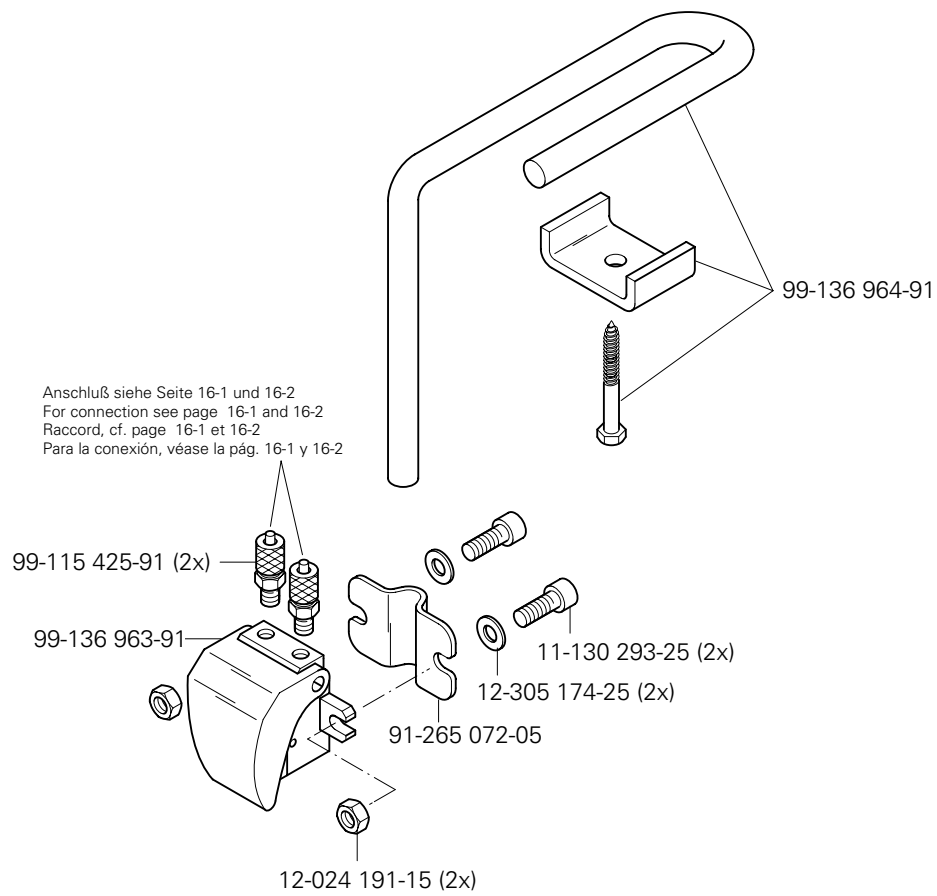
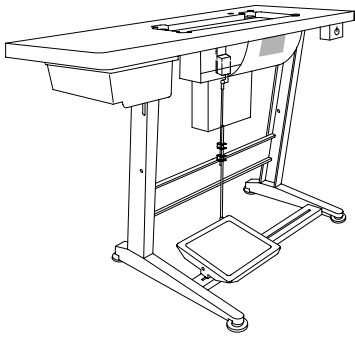

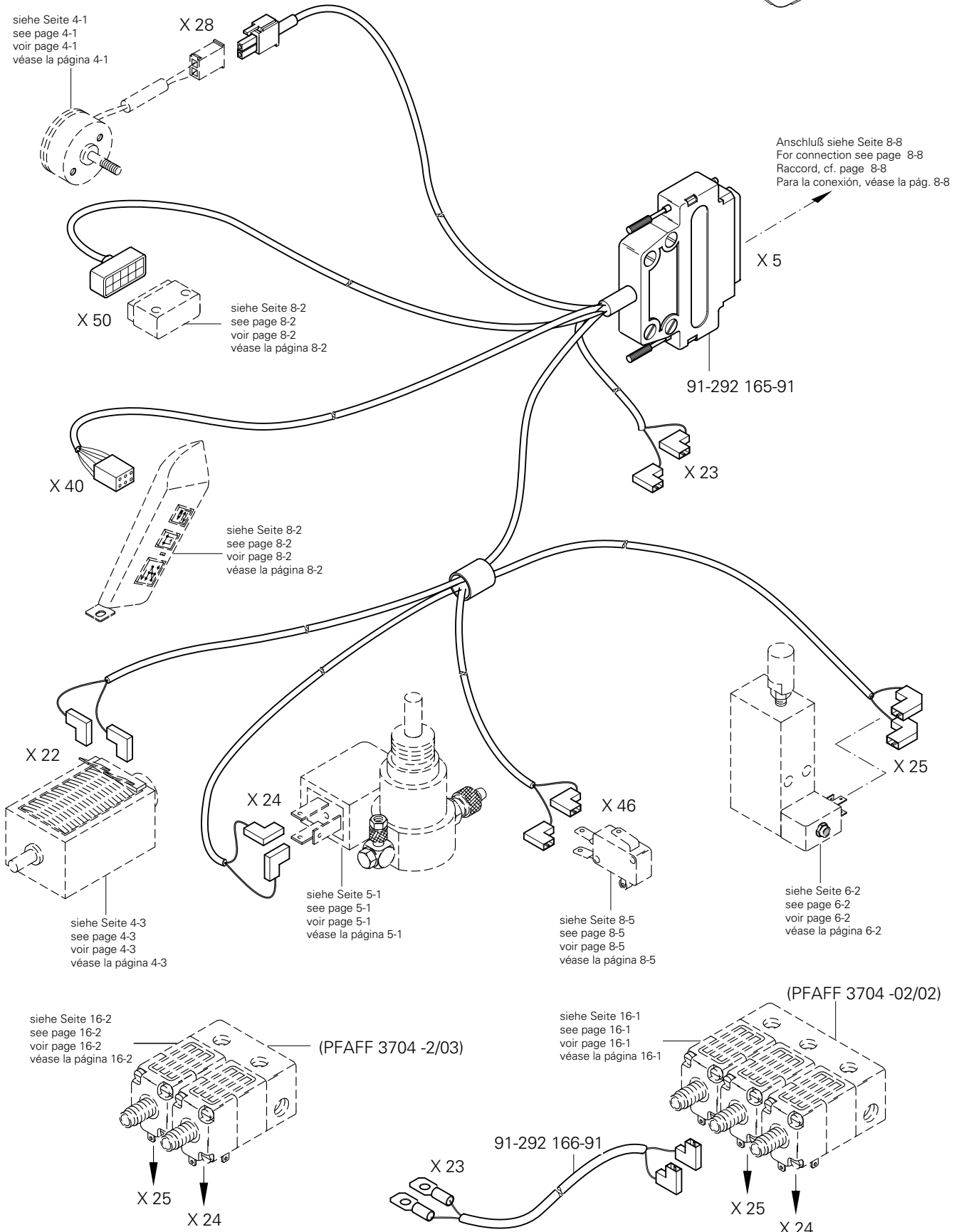
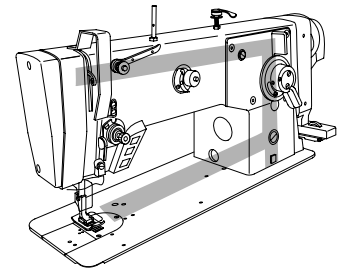

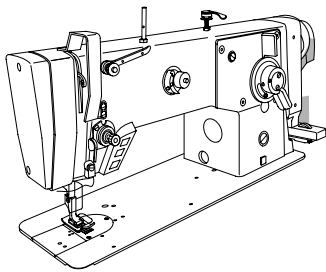

Positionsgeber
Synchronizer
Synchronisateur
Sincronizador

PFAFF 3704

17.02

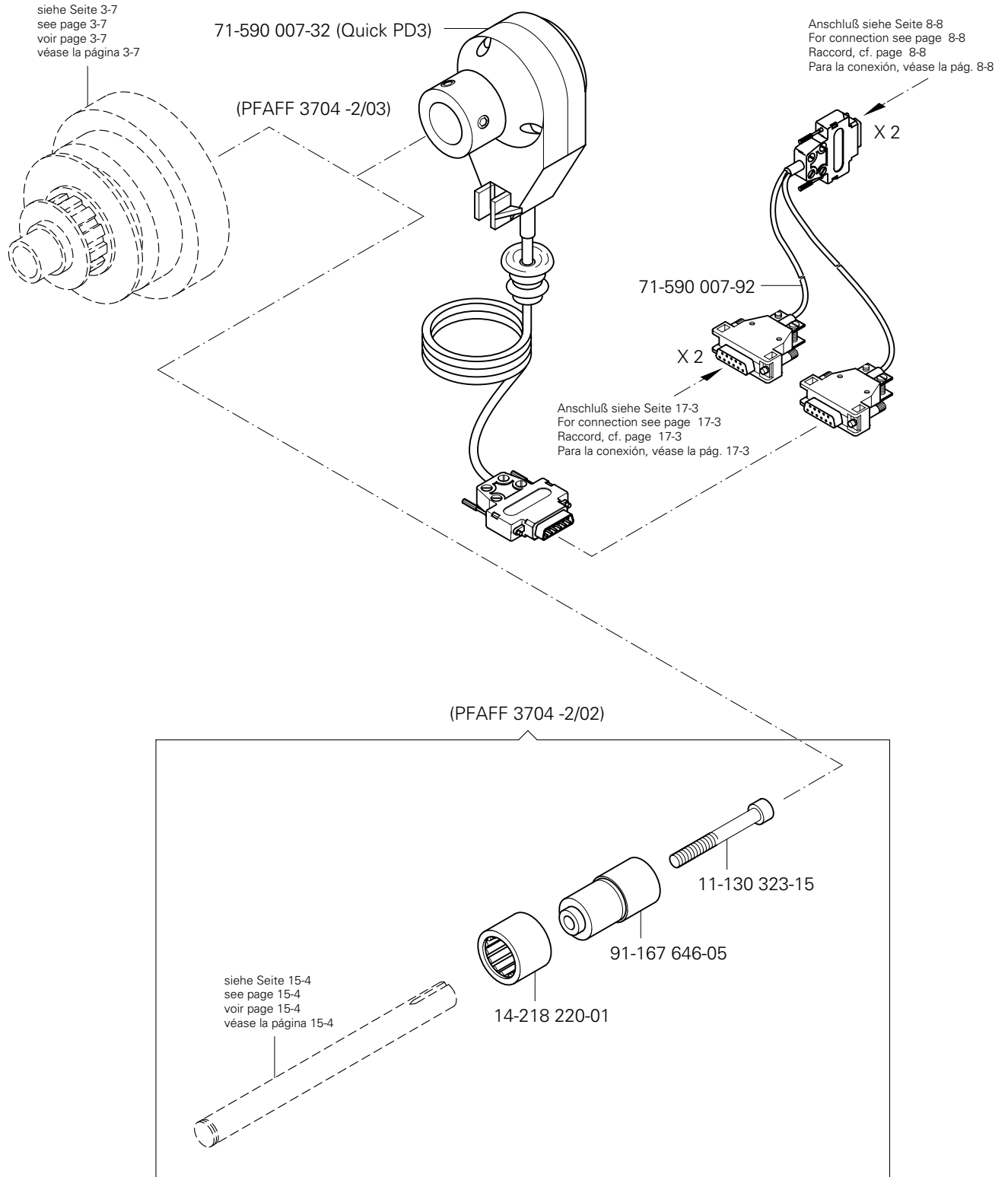

17.03

Anbausatz für externen Motor
 Mounting kit for external motor
 Jeu de pièces pour moteur externe
 Juego de piezas acoplables para motor externo

PFAFF 3704

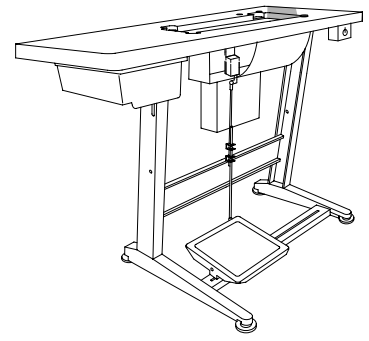

siehe Seite 3-7
 see page 3-7
 voir page 3-7
 véase la página 3-7

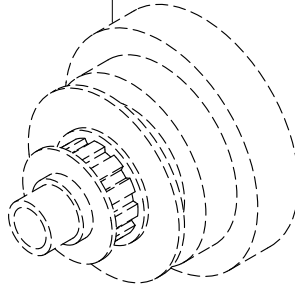

16-414 138-05

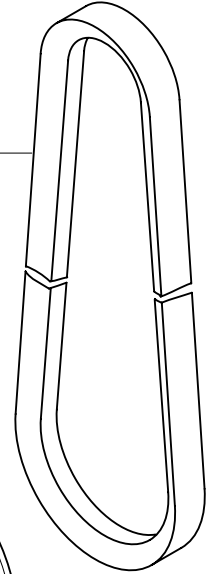

12-335 210-15 (3x)



11-039 378-15 (3x)

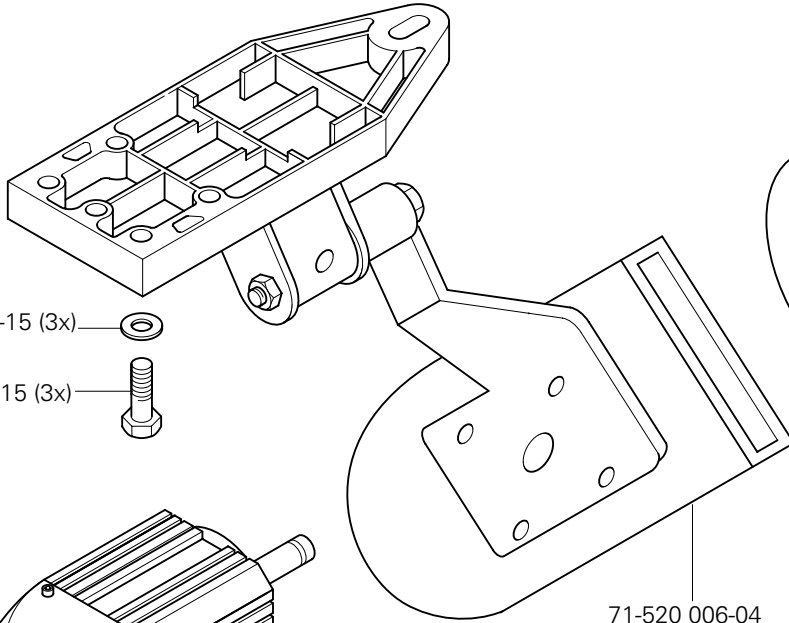

71-520 006-05

71-520 006-04

71-520 006-02

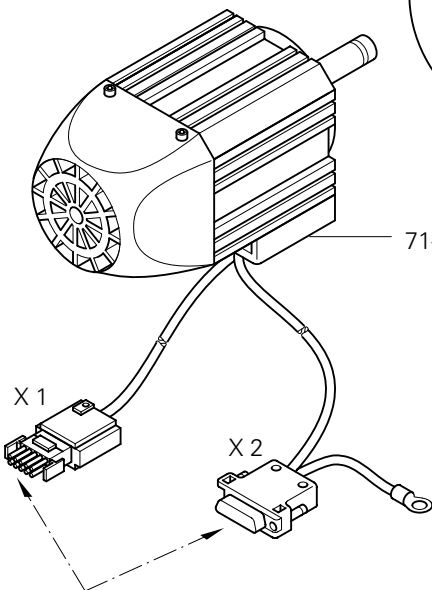

Anschluß siehe Seite 8-8
 For connection see page 8-8
 Raccord, cf. page 8-8
 Para la conexión, véase la pág. 8-8



No.	Seite Page Pages Página	No.	Seite Page Pages Página	No.	Seite Page Pages Página	No.	Seite Page Pages Página
11-039 360-15	12 - 1	11-130 227-15	4 - 3, 15 - 6	11-210 081-15	3 - 12	11-341 169-15	15 - 6
11-039 378-15	17 - 3	11-130 227-25	3 - 9	11-210 168-15	3 - 5, 15 - 2	11-341 280-15	3 - 2, 3 - 3, 3 - 15, 3 - 19, 3 - 22, 3 - 25
11-108 090-15	15 - 6	11-130 239-15	15 - 6	11-210 168-25	3 - 8	11-341 901-15	3 - 17, 4 - 3
11-108 093-15	3 - 19	11-130 257-15	6 - 2	11-210 169-15	15 - 3	11-341 902-15	3 - 7, 3 - 10, 3 - 13, 3 - 19, 3 - 20, 3 - 21, 3 - 22
11-108 102-15	8 - 5	11-130 257-25	3 - 11	11-210 178-15	15 - 2	11-341 904-15	3 - 3
11-108 111-15	3 - 3	11-130 287-15	3 - 1, 5 - 1, 15 - 8, 15 - 9	11-210 216-15	10 - 1	11-341 905-15	4 - 2
11-108 168-15	3 - 2, 3 - 14, 6 - 1, 15 - 1, 15 - 5	11-130 287-25	8 - 8	11-210 222-15	3 - 1, 3 - 2	11-345 907-15	3 - 12
11-108 171-15	3 - 1, 3 - 12, 3 - 26, 15 - 1	11-130 293-15	4 - 3, 8 - 4, 16 - 1, 16 - 2	11-210 265-15	3 - 7	11-460 163-15	8 - 7
11-108 174-15	3 - 2, 3 - 3, 3 - 16, 4 - 2 8 - 6	11-130 293-25	16 - 3	11-225 172-15	3 - 2	11-462 118-55	3 - 1
11-108 177-15	3 - 1, 3 - 10	11-130 299-15	15 - 6	11-225 232-15	8 - 4	11-462 154-55	8 - 5
11-108 198-15	16 - 1, 16 - 2	11-130 305-15	7 - 1	11-225 292-15	3 - 12, 15 - 8	11-462 250-15	8 - 7
11-108 222-15	3 - 1, 3 - 20, 15 - 1	11-130 317-15	15 - 6	11-225 298-15	3 - 11	11-724 907-55	4 - 3
11-108 222-25	3 - 1	11-130 323-15	17 - 2	11-225 315-15	15 - 3	12-005 195-15	3 - 2, 3 - 23, 3 - 24, 15 - 3, 15 - 8
11-108 225-15	3 - 2, 3 - 7, 3 - 13, 3 - 17, 3 - 20, 3 - 21, 3 - 23, 4 - 2, 15 - 5, 15 - 7, 16 - 1, 16 - 2	11-130 377-15	15 - 8	11-250 084-25	3 - 8	12-005 916-05	5 - 1
11-108 228-15	3 - 6, 3 - 23	11-130 906-15	3 - 1, 8 - 5	11-305 224-15	4 - 3	12-024 121-25	15 - 2
11-108 228-25	3 - 1	11-132 223-15	3 - 3	11-305 305-15	3 - 24	12-024 151-25	3 - 14, 3 - 24, 6 - 1
11-108 234-15	15 - 3	11-132 316-15	3 - 17	11-314 277-15	3 - 15, 3 - 19	12-024 171-25	4 - 2
11-108 237-15	3 - 1	11-173 096-15	3 - 14, 6 - 1, 15 - 5	11-314 946-15	3 - 3, 3 - 5, 15 - 2	12-024 172-15	4 - 2
11-108 237-25	3 - 1	11-173 168-25	3 - 5	11-317 970-15	3 - 14, 6 - 1, 15 - 5	12-024 191-15	3 - 10, 15 - 3, 15 - 6, 15 - 9, 16 - 1, 16 - 2, 16 - 3
11-108 258-15	3 - 1, 15 - 1	11-173 174-25	3 - 5, 15 - 2	11-320 224-15	15 - 8	12-024 191-25	3 - 8
11-108 258-15	15 - 7	11-174 089-15	4 - 2	11-330 166-15	3 - 4, 3 - 17	12-024 211-15	3 - 1, 5 - 1
11-108 285-15	15 - 7	11-174 170-15	3 - 12	11-330 205-15	8 - 6	12-305 084-15	15 - 6
11-108 285-25	10 - 1	11-174 173-15	3 - 4	11-330 217-15	3 - 3, 3 - 10	12-305 114-15	3 - 24, 4 - 3
11-108 294-15	3 - 23	11-174 176-15	3 - 22, 15 - 3	11-330 220-15	3 - 4, 3 - 13, 15 - 4	12-305 144-15	4 - 2, 8 - 5
11-130 108-15	3 - 11	11-174 176-25	3 - 5	11-330 277-15	8 - 4	12-305 174-15	3 - 10, 3 - 17, 15 - 3
11-130 170-25	8 - 2	11-174 233-15	12 - 1	11-330 952-15	3 - 8, 3 - 10, 3 - 15, 3 - 16 3 - 17, 3 - 20, 3 - 21	12-305 174-25	8 - 8, 16 - 3
11-130 173-15	15 - 6	11-174 353-15	6 - 2	11-330 960-15	3 - 17, 4 - 3	12-315 110-15	16 - 1, 16 - 2
11-130 176-15	3 - 10, 3 - 25, 3 - 26, 4 - 3	11-174 378-15	3 - 24	11-330 964-15	3 - 20	12-335 191-15	7 - 1, 16 - 1, 16 - 2
11-130 191-25	8 - 2	11-174 912-15	3 - 18	11-335 166-15	3 - 14, 6 - 1, 15 - 5	12-335 210-15	17 - 3
11-130 224-15	3 - 2, 3 - 11, 3 - 15, 3 - 16, 3 - 19	11-178 166-15	3 - 12	11-335 223-15	3 - 13	12-341 090-25	3 - 9
		11-178 292-15	3 - 14, 6 - 1	11-335 280-15	3 - 24		
		11-182 901-15	3 - 14, 6 - 1, 15 - 5	11-335 902-15	3 - 7, 3 - 13, 3 - 20		
		11-210 076-15	4 - 1				

No.	Seite Page Pages Página	No.	Seite Page Pages Página	No.	Seite Page Pages Página	No.	Seite Page Pages Página
12-499 150-45	8 - 6	13-052 095-55	15 - 2	15-120 911-05	3 - 9	26-536 302-09	3 - 4
12-499 190-45	15 - 6	13-060 903-05	3 - 9	15-120 921-05	3 - 9	28-011 201-05	14 - 1
12-501 170-45	4 - 3	13-065 259-05	3 - 4	15-120 924-05	3 - 9	28-011 201-46	14 - 1
12-501 190-45	4 - 3, 8 - 4	13-068 961-05	3 - 14, 6 - 1	15-128 020-75	3 - 1	28-011 201-99	14 - 1
12-610 170-45	3 - 9	13-069 250-05	4 - 3	15-130 074-05	3 - 6	28-011 202-05	14 - 1
12-610 190-45	3 - 10, 3 - 17, 3 - 23, 15 - 6	13-070 981-05	12 - 1	15-256 903-01	3 - 25	28-011 202-47	14 - 1
12-610 200-45	3 - 17	13-250 097-25	3 - 4	16-049 020-11	4 - 2	61-111 651-33	10 - 1
12-610 210-45	3 - 17, 3 - 22	14-012 545-01	3 - 17	16-049 021-11	4 - 2	71-120 006-31	8 - 5
12-610 230-45	3 - 3, 3 - 14, 6 - 1	14-012 555-01	3 - 17	16-409 915-05	3 - 20	71-130 006-39	8 - 2
12-610 250-45	15 - 4	14-015 624-91	3 - 20	16-409 985-05	8 - 4	71-170 002-24	4 - 3
12-610 280-45	3 - 19	14-016 080-01	3 - 17, 3 - 22	16-414 103-05	12 - 1	71-170 002-25	4 - 1
12-610 310-45	3 - 22, 15 - 7	14-016 100-01	15 - 4	16-414 138-05	17 - 3	71-370 001-08	8 - 7
12-618 080-45	3 - 12	14-016 130-01	3 - 13	16-919 051-15	3 - 12	71-370 001-32	3 - 2
12-624 170-45	3 - 10, 3 - 11	14-016 150-01	3 - 7	16-919 071-15	3 - 12	71-370 001-34	3 - 2
12-624 260-45	15 - 4	14-016 151-91	3 - 7, 3 - 20	18-272 010-25	16 - 1	71-370 002-92	8 - 7
12-640 130-55	3 - 8	14-017 100-01	3 - 10	18-277 001-91	16 - 1, 16 - 2	71-520 006-01	8 - 6
12-640 150-55	3 - 9, 15 - 6	14-018 570-01	3 - 2	18-278 005-91	16 - 1, 16 - 2	71-520 006-02	17 - 3
12-640 170-55	3 - 14, 6 - 1	14-018 644-91	3 - 7	18-279 032-45	16 - 1, 16 - 2	71-520 006-04	17 - 3
12-640 190-55	8 - 5	14-022 080-01	3 - 9	18-372 001-91	16 - 1, 16 - 2	71-520 006-05	17 - 3
12-640 210-55	15 - 6	14-210 440-01	3 - 13	18-372 003-91	7 - 1	71-523 555-63	8 - 4
12-640 220-55	3 - 19	14-218 220-01	17 - 2	18-372 004-91	5 - 1, 7 - 1	71-590 007-21	8 - 6
12-640 230-55	15 - 7	14-602 901-01	3 - 8	18-372 009-91	15 - 1	71-590 007-32	17 - 2
12-660 350-45	3 - 17	14-650 243-05	3 - 3	18-372 010-25	16 - 2	71-590 007-70	8 - 3
12-660 390-45	3 - 17, 3 - 22	15-032 001-45	15 - 1, 15 - 8, 15 - 9, 16 - 1, 16 - 2	18-378 001-91	15 - 8, 16 - 1, 16 - 2	71-590 007-72	8 - 3
12-660 410-45	15 - 4	15-032 002-45	7 - 1	18-378 008-91	5 - 1, 15 - 6, 15 - 9, 16 - 1, 16 - 2	71-590 007-82	8 - 8
12-710 230-12	15 - 8	15-120 038-05	3 - 1	18-378 009-91	16 - 1, 16 - 2	71-590 007-91	8 - 3
13-030 341-05	10 - 1	15-120 241-05	3 - 13, 15 - 4	18-379 001-91	16 - 1, 16 - 2	71-590 007-92	17 - 2
13-033 103-05	15 - 2	15-120 248-05	3 - 25	25-161 801-49	3 - 2, 3 - 17, 3 - 25, 3 - 26	71-770 000-63	8 - 2
13-033 148-05	15 - 2	15-120 536-05	3 - 9	25-308 820-30	6 - 2, 16 - 1, 16 - 2	91-000 250-15	3 - 18
13-033 196-05	3 - 3	15-120 705-05	3 - 25	25-308 820-40	16 - 1, 16 - 2	91-000 366-15	15 - 2
13-033 208-05	3 - 9	15-120 709-05	3 - 13	25-308 820-60	5 - 1, 7 - 1	91-000 390-05	3 - 18
13-033 256-05	3 - 9	15-120 712-05	3 - 25	26-536 301-09	3 - 2	91-002 065-05	3 - 5, 15 - 2
13-052 049-55	3 - 4					91-002 134-05	3 - 18

No.	Seite Page Pages Página	No.	Seite Page Pages Página	No.	Seite Page Pages Página	No.	Seite Page Pages Página
91-006 814-05	3 - 5, 15 - 2	91-069 079-72/895	3 - 3	91-100 120-25	3 - 12	91-167 305-01	15 - 5
91-006 818-05	3 - 5, 15 - 2	91-069 165-15	4 - 2, 4 - 3	91-100 270-15	3 - 12	91-167 311-71/893	3 - 14
91-008 627-05	15 - 2	91-069 172-15	3 - 1, 15 - 1	91-100 270-25	3 - 9	91-167 312-91	4 - 2
91-009 026-05	3 - 18	91-069 287-05	3 - 15, 3 - 16, 3 - 19	91-100 275-15	4 - 2	91-167 316-12	15 - 8
91-010 181-25	15 - 2	91-069 335-72/893	12 - 1	91-100 281-25	3 - 8	91-167 372-71/893	6 - 1
91-010 183-05	15 - 2	91-069 375-15	3 - 25	91-100 283-15	3 - 12	91-167 436-05	3 - 17
91-010 184-15	15 - 2	91-069 562-05	3 - 3	91-100 289-15	3 - 21	91-167 437-15	3 - 17
91-010 538-05	3 - 12	91-069 585-25	3 - 8	91-100 296-25	3 - 16	91-167 442-91	3 - 22
91-020 324-05	4 - 3	91-083 772-15	15 - 6	91-100 331-15	3 - 6	91-167 443-05	3 - 22
91-020 877-05	3 - 9	91-083 781-11	15 - 7	91-105 447-25	15 - 2	91-167 463-71/893	3 - 12
91-021 124-15	15 - 6	91-084 321-05	15 - 7	91-107 204-25	3 - 15	91-167 464-75/895	3 - 12
91-025 212-05	15 - 6	91-084 474-05	15 - 9	91-118 099-91	3 - 8	91-167 467-21	3 - 12
91-027 285-05	3 - 9	91-084 475-75/893	15 - 1	91-118 612-05	4 - 2, 4 - 3	91-167 481-72/895	3 - 1
91-027 289-15	12 - 1	91-084 591-05	15 - 6	91-118 681-05	3 - 8	91-167 487-15	3 - 26
91-027 370-05	12 - 1	91-084 598-75/895	15 - 6	91-118 683-05	3 - 8	91-167 491-05	3 - 22, 3 - 23, 15 - 7
91-027 371-12	12 - 1	91-084 751-15	15 - 6	91-118 766-05	15 - 3	91-167 492-92	3 - 21
91-027 645-75/699	10 - 1	91-084 766-75/895	15 - 6	91-118 893-92	4 - 3	91-167 510-05	3 - 13
91-027 975-91	14 - 1	91-084 776-11	15 - 6	91-119 886-05	15 - 2	91-167 543-15	3 - 12
91-027 976-91	14 - 1	91-084 779-15	15 - 6	91-125 009-05	3 - 17	91-167 544-05	3 - 12
91-027 977-91	14 - 1	91-084 780-15	15 - 6	91-129 996-01	10 - 1	91-167 545-15	3 - 12
91-029 692-75/792	12 - 1	91-084 785-15	15 - 6	91-140 945-05	3 - 18	91-167 546-05	4 - 2
91-031 888-15	3 - 23	91-084 786-15	15 - 6	91-161 334-25	3 - 5	91-167 561-05	3 - 12
91-032 087-45	3 - 1	91-087 591-75/895	15 - 6	91-165 951-91	5 - 1	91-167 573-11	15 - 2
91-032 203-15	3 - 23	91-087 592-11	15 - 6	91-165 952-05	5 - 1	91-167 587-71/893	15 - 5
91-032 211-15	3 - 23	91-087 595-15	15 - 6	91-166 452-21	3 - 8	91-167 586-05	3 - 7
91-033 915-21	10 - 1	91-087 596-15	15 - 9	91-167 091-25	3 - 12	91-167 595-05	3 - 18
91-038 801-75/699	10 - 1	91-087 597-12	15 - 7	91-167 135-92	3 - 17	91-167 597-91	3 - 18
91-056 192-25	3 - 5, 3 - 8	91-087 598-04/001	15 - 7	91-167 137-92	3 - 17	91-167 598-41	3 - 18
91-056 193-25	3 - 5, 3 - 8	91-087 602-71/893	15 - 1	91-167 138-05	3 - 17	91-167 603-05	3 - 3
91-056 197-91	3 - 5	91-087 603-75/893	15 - 1	91-167 231-91	3 - 4	91-167 604-25	3 - 3
91-056 198-21	3 - 5	91-087 604-75/893	15 - 1	91-167 264-15	15 - 8	91-167 606-91	3 - 3
91-056 578-91	3 - 8	91-088 027-91	15 - 9	91-167 301-01	15 - 5	91-167 607-01	15 - 3
91-056 760-05	3 - 5	91-088 029-71/893	16 - 1	91-167 303-75/893	15 - 5	91-167 617-91	15 - 3

No.	Seite Page Pages Página	No.	Seite Page Pages Página	No.	Seite Page Pages Página	No.	Seite Page Pages Página
91-167 621-05	3 - 12	91-168 029-92	3 - 2	91-168 146-21	3 - 12	91-168 300-12	3 - 17
91-167 624-91	15 - 3	91-168 030-05	3 - 2	91-168 147-75/893	3 - 12	91-168 303-05	3 - 18
91-167 646-05	17 - 2	91-168 039-05	3 - 4	91-168 150-05	3 - 12	91-168 304-01	15 - 1
91-167 652-72/951	15 - 8	91-168 041-05	3 - 4	91-168 153-05	3 - 12	91-168 310-91	3 - 19
91-167 655-11	6 - 2	91-168 042-05	3 - 4	91-168 154-05	3 - 12	91-168 315-12	3 - 15, 3 - 16, 3 - 19
91-167 659-92	15 - 8	91-168 043-91	3 - 2	91-168 155-05	3 - 3	91-168 318-05	3 - 19
91-167 673-11	4 - 2	91-168 044-05	3 - 2	91-168 161-05	3 - 6	91-168 319-12	3 - 15
91-167 710-91	3 - 3	91-168 045-05	3 - 2	91-168 163-01	3 - 3	91-168 320-91	3 - 19
91-167 715-92	3 - 3	91-168 048-91	3 - 2	91-168 170-91	3 - 6	91-168 323-12	3 - 15, 3 - 16
91-167 724-05	3 - 17	91-168 054-92	3 - 7	91-168 173-05	3 - 3	91-168 331-05	3 - 24
91-167 731-75/893	6 - 1	91-168 055-91	3 - 7	91-168 192-25	3 - 5, 15 - 2	91-168 337-92	3 - 20
91-167 754-71/951	15 - 8	91-168 057-15	3 - 7	91-168 200-91	15 - 5	91-168 344-05	3 - 19
91-167 780-05	15 - 8	91-168 062-15	3 - 2	91-168 201-12	3 - 23, 15 - 5	91-168 347-05	3 - 19
91-167 786-91	15 - 2	91-168 063-25	3 - 5	91-168 202-15	3 - 22, 15 - 7	91-168 350-12	3 - 16
91-167 788-15	15 - 2	91-168 066-92	3 - 4	91-168 204-15	3 - 23, 15 - 5	91-168 352-15	3 - 16
91-167 789-15	15 - 2	91-168 069-05	15 - 3	91-168 206-12	3 - 23, 15 - 5	91-168 353-91	3 - 16
91-167 790-15	15 - 2	91-168 081-05	15 - 3	91-168 213-05	3 - 14, 6 - 1	91-168 370-71/951	3 - 24
91-167 798-21	15 - 2	91-168 084-91	15 - 3	91-168 214-15	3 - 14, 6 - 1, 15 - 5	91-168 371-75/951	3 - 24
91-167 800-91	3 - 21	91-168 088-15	3 - 11, 15 - 3	91-168 218-91	3 - 14, 6 - 1, 15 - 5	91-168 372-05	3 - 24
91-167 807-91	3 - 12	91-168 089-11	3 - 23	91-168 221-92	15 - 5	91-168 373-92	3 - 24
91-167 828-05	3 - 14, 6 - 1, 15 - 5	91-168 092-05	3 - 15, 3 - 16	91-168 223-01	3 - 14, 6 - 1	91-168 375-71/893	12 - 1
91-167 829-05	15 - 5	91-168 099-04	3 - 7	91-168 235-25	15 - 4	91-168 376-15	12 - 1
91-167 830-05	3 - 14, 6 - 1	91-168 106-05	3 - 10, 15 - 3	91-168 245-05	3 - 7	91-168 377-05	3 - 24
91-167 831-71/893	3 - 14	91-168 108-05	3 - 1, 15 - 1	91-168 256-05	3 - 24	91-168 381-15	3 - 1
91-167 832-01	3 - 14, 6 - 1	91-168 117-05	3 - 2	91-168 266-92	3 - 17	91-168 382-05	3 - 1
91-167 915-90	3 - 17	91-168 122-05	3 - 12	91-168 269-05	3 - 17	91-168 383-05	3 - 1
91-167 918-92	3 - 20	91-168 123-05	3 - 12	91-168 276-05	3 - 17	91-168 384-05	3 - 1
91-167 919-92	3 - 22	91-168 125-05	3 - 12	91-168 277-05	3 - 23, 15 - 5	91-168 385-05	3 - 22
91-167 987-91	15 - 2	91-168 131-01	3 - 12	91-168 281-05	3 - 22	91-168 389-91	3 - 4
91-167 996-75/893	3 - 1	91-168 134-05	3 - 12	91-168 284-15	3 - 22	91-168 434-01	3 - 17
91-167 997-75/893	3 - 1	91-168 136-01	3 - 12	91-168 290-91	3 - 22	91-168 438-05	3 - 2
91-168 019-91	3 - 4	91-168 139-72/893	3 - 12	91-168 293-12	3 - 17	91-168 442-15	3 - 17
91-168 020-01	3 - 4	91-168 144-05	3 - 18	91-168 295-91	3 - 17	91-168 443-05	3 - 6

No.	Seite Page Pages Página	No.	Seite Page Pages Página	No.	Seite Page Pages Página	No.	Seite Page Pages Página
91-168 480-15	3 - 7	91-168 565-15	3 - 14, 6 - 1	91-171 971-05	3 - 2	91-264 358-05	3 - 8
91-168 493-91	3 - 20	91-168 571-05	15 - 4	91-172 939-05	3 - 14, 6 - 1	91-265 052-75/895	3 - 1
91-168 494-04/002	3 - 22	91-168 572-93	3 - 13	91-174 279-92	3 - 3	91-265 072-05	16 - 3
91-168 496-92	3 - 20	91-168 574-91	3 - 7	91-174 396-05	3 - 5, 15 - 2	91-265 225-91	3 - 18
91-168 498-15	4 - 2	91-168 575-91	3 - 7	91-174 438-25	3 - 5, 15 - 2	91-265 227-05	3 - 18
91-168 499-05	4 - 2	91-168 577-71/893	3 - 7	91-174 439-25	3 - 5, 15 - 2	91-266 114-15	3 - 1
91-168 503-92	3 - 21	91-168 578-91	3 - 7	91-174 440-25	3 - 5, 15 - 2	91-266 397-01	3 - 8
91-168 505-91	3 - 15	91-168 579-91	3 - 20	91-174 441-05	3 - 5, 15 - 2	91-266 757-05	4 - 1
91-168 509-91	3 - 19	91-168 592-05	3 - 22	91-174 454-91	3 - 5, 15 - 2	91-266 852-75/893	8 - 5
91-168 511-04/002	3 - 23	91-168 593-05	3 - 19	91-174 455-15	3 - 5, 15 - 2	91-266 856-25	10 - 1
91-168 512-91	3 - 15	91-168 720-75/698	3 - 1, 3 - 9	91-174 501-15	3 - 1	91-268 016-91	3 - 2
91-168 513-15	3 - 15	91-168 810-05	3 - 3	91-174 503-15	3 - 1	91-268 032-91	3 - 20
91-168 514-12	3 - 15	91-168 924-05	3 - 1	91-174 504-15	3 - 1	91-268 033-92	3 - 20
91-168 515-05	3 - 15	91-168 928-05	15 - 3	91-174 507-05	3 - 18	91-268 035-72/893	3 - 1
91-168 521-91	3 - 23	91-168 929-05	15 - 3	91-174 733-25	15 - 2	91-268 037-91	3 - 2
91-168 523-15	3 - 23	91-168 961-15	4 - 2	91-174 783-05	3 - 8	91-268 040-05	3 - 2
91-168 525-12	3 - 23	91-168 968-91	3 - 10	91-174 879-05	3 - 8	91-268 051-72/893	15 - 1
91-168 526-05	3 - 23	91-168 972-05	3 - 10	91-175 690-05	3 - 18	91-268 055-03/002	3 - 4
91-168 527-91	3 - 23	91-168 979-05	3 - 10	91-177 464-75/893	16 - 1, 16 - 2	91-268 066-02	3 - 1
91-168 528-15	3 - 23	91-168 980-05	3 - 10	91-187 386-15	7 - 1	91-268 099-91	3 - 4
91-168 529-15	3 - 23	91-168 981-05	3 - 10	91-187 426-70/893	7 - 1	91-268 102-91	3 - 4
91-168 530-12	3 - 23	91-168 987-25	3 - 12	91-188 354-12	15 - 7	91-268 220-05	3 - 12
91-168 533-91	3 - 21	91-168 989-05	3 - 10	91-188 624-75/893	15 - 1	91-268 227-05	3 - 13
91-168 538-01	3 - 14, 6 - 1	91-169 166-05	3 - 6	91-188 625-75/893	15 - 1	91-268 233-05	3 - 10
91-168 543-05	3 - 14, 6 - 1	91-170 809-05	15 - 7	91-188 715-71/893	15 - 1	91-268 234-05	3 - 10
91-168 544-05	3 - 14, 6 - 1	91-171 042-05	3 - 8	91-188 720-72/895	15 - 1	91-268 241-92	3 - 10
91-168 546-01	3 - 14, 6 - 1	91-171 049-05	3 - 8	91-188 721-71/895	15 - 1	91-268 247-05	3 - 9, 3 - 11
91-168 550-11	3 - 14, 6 - 1	91-171 288-12	15 - 7	91-229 070-70/895	9 - 1	91-268 254-91	3 - 11
91-168 553-92	3 - 14, 6 - 1	91-171 409-12	3 - 22, 3 - 23, 15 - 7	91-229 180-90	8 - 7	91-268 255-05	3 - 11
91-168 555-21	3 - 14, 6 - 1	91-171 549-05	15 - 2	91-229 287-75/699	10 - 1	91-268 256-91	3 - 10
91-168 559-92	3 - 14, 6 - 1	91-171 561-15	15 - 2	91-229 403-91	14 - 1	91-268 258-92	3 - 10
91-168 561-91	3 - 14, 6 - 1	91-171 562-15	15 - 2	91-262 385-75/893	8 - 6	91-268 632-71/895	3 - 9
91-168 563-05	3 - 14, 6 - 1	91-171 565-01	15 - 2	91-264 357-05	3 - 8	91-268 635-05	3 - 9

No.	Seite Page Pages Página	No.	Seite Page Pages Página	No.	Seite Page Pages Página	No.	Seite Page Pages Página
91-268 636-05	3 - 9	91-268 698-05	3 - 13	95-774 346-15	4 - 2	99-135 835-05	16 - 1, 16 - 2
91-268 637-05	3 - 9	91-268 700-05	3 - 13	95-774 347-11	4 - 2	99-136 546-91	7 - 1
91-268 638-75/895	3 - 9	91-268 702-05	3 - 10	95-774 348-15	8 - 4	99-136 854-55	8 - 6, 8 - 8
91-268 639-25	3 - 9	91-268 704-05	3 - 11	95-774 369-75/895	3 - 1	99-136 881-91	5 - 1
91-268 641-71/895	3 - 11	91-268 711-71/895	3 - 1	95-774 372-91	4 - 3	99-136 963-91	16 - 3
91-268 642-75/895	3 - 11	91-268 712-05	3 - 1	95-774 373-92	4 - 3	99-136 964-91	16 - 3
91-268 643-05	3 - 11	91-268 719-70	10 - 1	95-774 391-15	5 - 1	99-137 151-45	3 - 8
91-268 644-05	3 - 11	91-268 720-75/895	3 - 1	95-774 392-15	5 - 1	99-137 196-05	8 - 6
91-268 645-01	3 - 11	91-268 731-05	3 - 10	95-774 414-15	8 - 5	99-137 390-05	3 - 25
91-268 649-05	3 - 25	91-269 027-11	8 - 4	95-774 416-15	8 - 5	99-137 391-05	3 - 17
91-268 650-91	3 - 25	91-291 458-91	8 - 8	95-774 430-11	8 - 5	99-137 398-91	6 - 2
91-268 651-05	3 - 25	91-291 899-91	8 - 8	95-774 433-71/895	8 - 5		
91-268 652-01	3 - 17	91-292 136-91	8 - 1	95-774 468-05	8 - 5		
91-268 654-05	3 - 25	91-292 165-91	17 - 1	95-774 512-15	8 - 5		
91-268 655-05	3 - 25	91-292 166-91	17 - 1	95-774 567-05	15 - 7		
91-268 656-05	3 - 25	91-700 226-15	3 - 12	99-115 425-91	16 - 3		
91-268 657-01	3 - 26	91-700 249-15	4 - 2	99-133 042-91	16 - 1, 16 - 2		
91-268 659-05	3 - 25	91-700 338-25	15 - 2	99-133 093-91	15 - 2		
91-268 660-91	3 - 26	91-700 655-15	15 - 6	99-133 374-91	15 - 6		
91-268 666-06	3 - 10	91-700 689-15	3 - 7	99-134 299-91	16 - 1, 16 - 2		
91-268 668-75/895	8 - 3	91-700 785-15	3 - 15, 3 - 19, 3 - 21, 3 - 22, 3 - 23, 15 - 7	99-134 361-91	16 - 2		
91-268 669-91	3 - 17	91-701 179-15	3 - 4	99-134 498-91	15 - 8		
91-268 671-70	8 - 3	91-701 344-15	15 - 5	99-134 580-91	16 - 1, 16 - 2		
91-268 672-05	4 - 1	91-701 522-25	15 - 2	99-134 850-91	16 - 1		
91-268 681-07	3 - 10	95-665 735-91	14 - 1	99-134 886-91	15 - 9		
91-268 682-75/698	3 - 9	95-721 192-11	4 - 2	99-134 901-91	15 - 1		
91-268 683-25	3 - 9	95-721 193-91	4 - 2	99-134 961-91	16 - 1		
91-268 684-05	3 - 9	95-774 265-91	4 - 3	99-135 350-91	16 - 1, 16 - 2		
91-268 690-92	3 - 10	95-774 266-15	4 - 3	99-135 549-91	15 - 2		
91-268 692-05	3 - 10	95-774 267-15	4 - 3	99-135 617-95	16 - 1, 16 - 2		
91-268 693-91	15 - 4	95-774 268-15	5 - 1	99-135 775-91	5 - 1		
91-268 694-92	15 - 4	95-774 345-05	3 - 20	99-135 776-91	5 - 1		
91-268 697-01	3 - 13			99-135 777-95	5 - 1		

PFAFF

939 U

3704^{-2/02}_{-2/03}

Unterklassen-Ausstattung

Subclass parts

Composition des sous-classes

Composición de las subclases

19.01

Nähwerkzeuge[▲]
Gauge parts
Organes de couture
Organos de costura

PFAFF 939-U

-6/01

Für allgemeine Näharbeiten. For ordinary sewing operations.
Standardform des Teilesatzes. Standard part set.

Travaux d'utilité courante.
Jeu de pièces standard.

Para trabajos de costura en general.
Juego de piezas estándar.

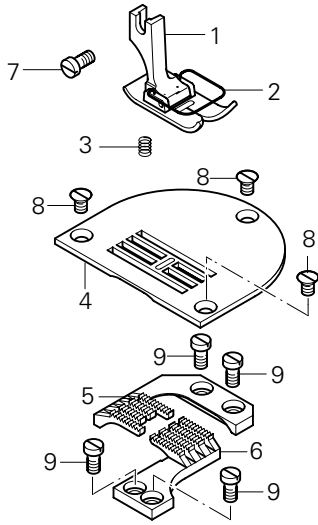

Pos.-Nr. Item No. N° pos.	Ausführung Model Version Tipo	Stichlänge Stitch length Longeur du point Largo de puntada	Überstichbreite Stitch width Amplitude zigzag Ancho de zig-zag	Teile-Nr. Part No. N° de piezas
1 - 6	B [◆]	4,5	6,0	91-201 102-93/001
1 - 3	B [◆]	4,5	6,0	91-054 695-23/001
2	B [◆]	4,5	6,0	91-057 133-04/001 <u>3/1</u>
3				91-051 724-05
4	B [◆]	4,5	6,0	91-058 034-24/002
5 - 6	B [◆]	4,5	6,0	91-047 381-03/002
5	B [◆]	4,5	6,0	91-047 383-04/002
6	B [◆]	4,5	6,0	91-047 382-04/002
7				11-108 174-25
8				91-100 296-25
9				11-108 174-15

19.01

Nähwerkzeuge[▲]
Gauge parts
Organes de couture
Organos de costura

PFAFF 939-U

-32/23

Arbeitsgang
Operation
Opération
Operación

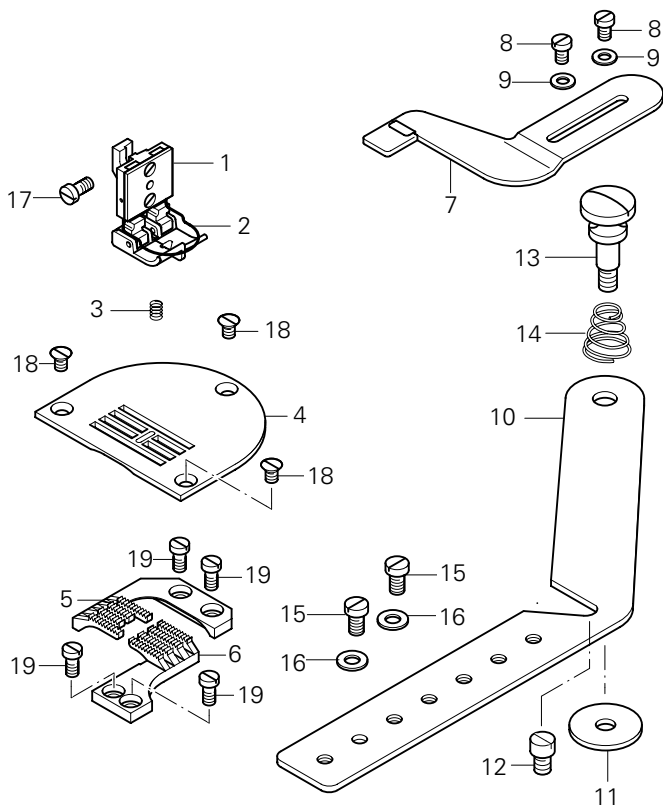
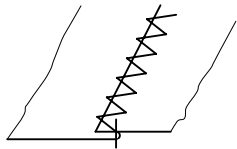

Pos.-Nr. Item No. N° pos.	Ausführung Model Version Tipo	Stichlänge Stitch length Longeur du point Largo de puntada	Überstichbreite Stitch width Amplitude zigzag Ancho de zig-zag	Teile-Nr. Part No. N° de piezas
1 - 16	B [◆]	N24 [◆]	6,0	91-201 103-93/001
1 - 3	B [◆]	N24 [◆]	6,0	91-157 299-93/001
2				91-157 303-05 <u>3/1</u>
3				91-010 099-05
4	B [◆]	N24 [◆]	6,0	91-058 113-24/003
5 - 6	B [◆]	N24 [◆]	6,0	91-047 746-03/003
5	B [◆]	N24 [◆]	6,0	91-047 748-04/003
6	B [◆]	N24 [◆]	6,0	91-047 747-04/003
7 - 9				91-050 946-23/001
8				11-108 168-15
9				12-305 114-15
10 - 16				91-753 936-90
10				91-753 936-25
11				91-028 036-25
12				91-100 288-25
13				91-700 824-25
14				91-040 624-25
15				11-108 168-15
16				12-305 114-15
17				11-108 174-25
18				91-100 296-25
19				11-108 174-15

19 - 2

▲ Weitere Unterklassen und Ausführungen auf Anfrage
Further Subclasses and versions on enquiry
Autres sous-classes et modèles sur demande
Otras subclases y tipos, sobre demanda

☐ siehe Kapitel 2 Erläuterung der Schlüsselzeichen
see chapter 2 Explanation of key markings
voir le chap. 2 Explication des symboles
véase el Cap. 2 Explicaciones de los signos clave

PFAFF

-2/02

Arbeitsgang
 Operation
 Opération
 Operación

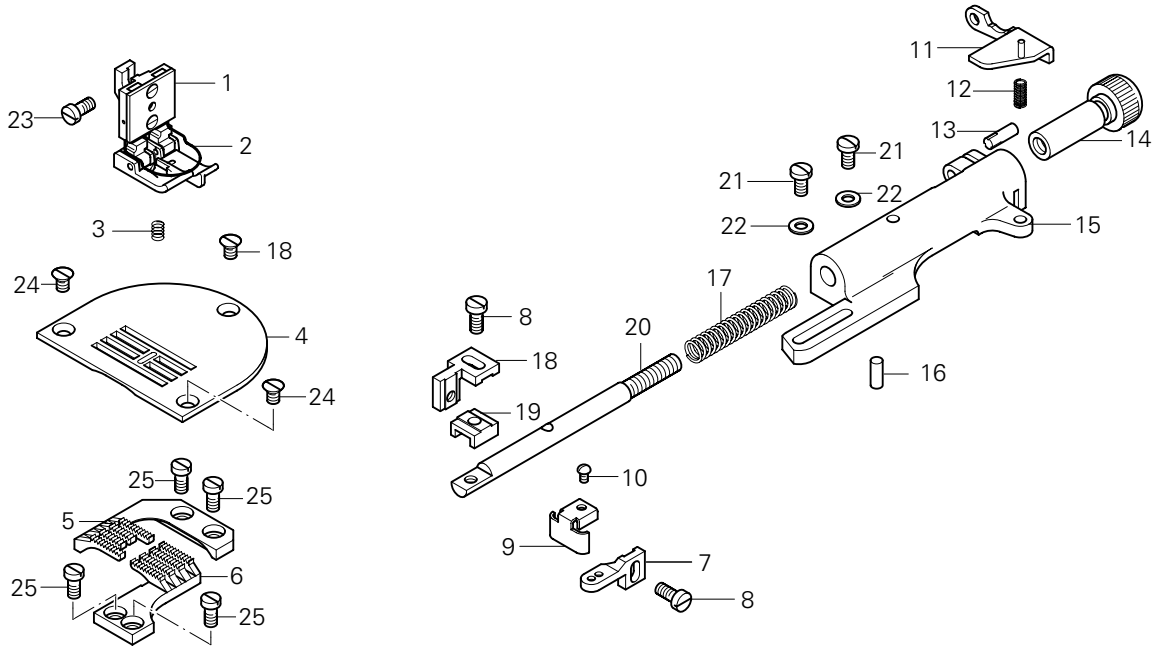
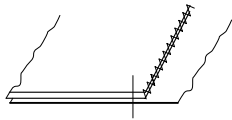

Pos.-Nr. Item No. N° pos.	Ausführung Model Version Tipo	Stichlänge Stitch length Longeur du point Largo de puntada	Überstichbreite Stitch width Amplitude zigzag Ancho de zig-zag	Teile-Nr. Part No. N° de piezas N° de pieza	Pos.-Nr. Item No. N° pos.	Ausführung Model Version Tipo	Stichlänge Stitch length Longeur du point Largo de puntada	Überstichbreite Stitch width Amplitude zigzag Ancho de zig-zag	Teile-Nr. Part No. N° de piezas N° de pieza
1 - 22	B [♦]	N24 [♦]	6,0	91-201 106-93/002	12			91-009 518-05	
1 - 3	B [♦]	N24 [♦]	6,0	91-155 047-91	13			13-063 247-05	
2				91-157 303-05[3/1]	14			91-053 607-15	
3				91-010 099-05	15			91-053 604-75/895	
4	B [♦]	N24 [♦]	6,0	91-058 113-24/003	16			13-033 244-05	
5 - 6	B [♦]	N24 [♦]	6,0	91-047 746-03/003	17			91-053 606-05	
5	B [♦]	N24 [♦]	6,0	91-047 748-04/003	18			91-014 791-15	
6	B [♦]	N24 [♦]	6,0	91-047 747-04/003	19			91-014 790-15	
7 - 20				91-053 620-71/895	20			91-053 605-05	
7				91-053 619-15	21			91-700 486-15	
8				91-000 073-15	22			12-305 114-15	
9				91-053 616-15	23			11-108 174-25	
10				91-700 996-15	24			91-100 296-25	
11 - 20				91-053 603-71/895	25			11-108 174-15	
11				91-156 517-11					

-2/03

Arbeitsgang
Operation
Opération
Opéracion

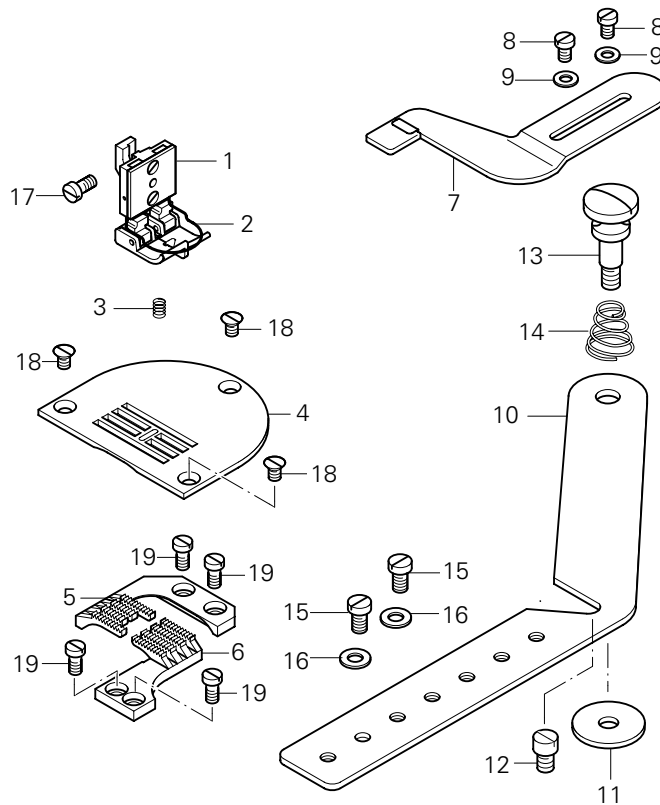
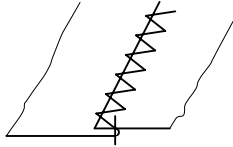

Pos.-Nr. Item No. N° pos. N° de pos.	Ausführung Model Version Tipo	Stichlänge Stitch length Longeur du point Largo de puntada	Überstichbreite Stitch width Amplitude zigzag Ancho de zig-zag	Teile-Nr. Part No. N° de piezas N° de pieza
1 - 16	B♦	N24♦	6,0	91-201 103-93/001
1 - 3	B♦	N24♦	6,0	91-157 299-93/001
2				91-157 303-05[3/1]
3				91-010 099-05
4	B♦	N24♦	6,0	91-058 113-24/003
5 - 6	B♦	N24♦	6,0	91-047 746-03/003
5	B♦	N24♦	6,0	91-047 748-04/003
6	B♦	N24♦	6,0	91-047 747-04/003
7 - 9				91-050 946-23/001
8				11-108 168-15
9				12-305 114-15

Pos.-Nr. Item No. N° pos. N° de pos.	Ausführung Model Version Tipo	Stichlänge Stitch length Longeur du point Largo de puntada	Überstichbreite Stitch width Amplitude zigzag Ancho de zig-zag	Teile-Nr. Part No. N° de piezas N° de pieza
10 - 16				91-753 936-90
10				91-753 936-25
11				91-028 036-25
12				91-100 288-25
13				91-700 824-25
14				91-040 624-25
15				11-108 168-15
16				12-305 114-15
17				11-108 174-25
18				91-100 296-25
19				11-108 174-15

PFAFF

PFAFF Industrie Maschinen AG

Postfach 3020
D-67653 Kaiserslautern

Königstr. 154
D-67655 Kaiserslautern

Telefon: (0631) 200-0
Telefax: (0631) 17202
E-Mail: info@pfaff-industrial.com

Gedruckt in der BRD
Printed in Germany
Imprimé en R.F.A.
Impreso en la R.F.A.