



MA 2081

MA 2083

Teileliste

Parts list

Lista de piezas

零件表

This manual applies to all machines of the mentioned type from the following serial number onward: # 100011 →

本零件表对从下列序列号起的机器有效：

Alle Informationen und Abbildungen waren zum Zeitpunkt der Druckgebung auf dem neusten Stand.

Technische Änderungen vorbehalten!

Der Nachdruck, die Vervielfältigung sowie die Übersetzung - auch auszugsweise - aus Mauser Spezial-Teilelisten ist nur mit unserer vorherigen Zustimmung und mit der Quellenangabe gestattet.

At the time of printing, all information and illustrations contained in this document were up to date.

Subject to alteration!

The reprinting, copying or translation of Mauser Spezial Parts lists whether in whole or in part, is only permitted with our previous permission and with written reference to the source.

Todas las informaciones e ilustraciones de este manual estaban al día en el momento de entregarse para su impresión.

¡ Salvo modificaciones técnicas!

La reimpresión, reproducción y traducción - aunque sólo sea parcial - de las listas de piezas Mauser Spezial sólo está permitida con nuestro permiso previo e indicando la fuente.

所有信息和图片在付印时都是最新的。

保留技术更改的权力！

全部或部分翻印、复制以及翻译 Mauser Spezial 零件表必须事先经由我们同意并且注明来源。

Mauser Spezial

Pfaff Industrial (Taicang) Co., Ltd.
No. 105 Shanghai East Road
A20 Foreign Industrial Park
215400 Taicang, Jiangsu
People's Republic of China

	Seite Page Página 页
0 Wichtiger Hinweis Important note Observación importante 重要提示	7
1 Vorwort Foreword Notas preliminares 前言	8
2 Erläuterungen der Schlüsselzeichen Explanation of key markings Explicaciones de los signos clave 标记说明	9
3 Basismaschine Basic machine Máquina básica 基础机器	11
3.01 Gehäuseteile Housing sections Piezas del cárter 机身零件	11
3.02 Kopfteile Needle head parts Piezas de la cabeza 机头零件	12
3.03 Armteile Arm parts Piezas del brazo 机臂零件	16
3.04 Grundplattenteile Bedplate parts Piezas del cárter 底板零件	24
4 Abweichende Teile der MA 2081-G;2083-G Different parts for MA 2081-G;2083-G Piezas de la MA 2081-G;2083-G que son diferentes MA 2081-G;2083-G 中有差别的零件	31
5 SRP	34
6 Kanten-Beschneideinrichtung (-731/01) Edge trimmer (-731/01) Recortador (-731/01) 切边器 (-731/01)	37
7 Fadenabschneid-Einrichtung (-900/24) Thread trimmer (-900/24) Cortahilos (-900/24) 切线器 (-900/24)	40

	Seite Page Página 页
8 Fadenklemme (-909/14) Thread trapper (-909/14) Pinza suje tahlilos (-909/14) 夹线器 (-909/14)	43
9 Presserfuß -Automatik (-910/06) Automatic presser foot lifter (-910/06) Grupo acondicionador del aire comprimido (-910/06) 压脚自动提升器 (-910/06)	44
10 Verriegelungs-Einrichtung (-911/37)..... Bactacking mechanism (-911/37) Rematador (-911/37) 锁紧装置 (-911/37)	45
11 Spulensfadenvorratswächter (-926/06)..... Bobbin thread supply monitor (-926/06) Detector del hilo de la canilla (-926/06) 底线余量监视器 (-926/06)	47
12 Walzentransport-Einrichtung (-948/26) Puller feed (-948/26) Puller (-948/26) 滚筒送料器 (-948/26)	48
13 Elektrische Ausrüstung Electrical equipment Equipo eléctrico 电气设备	50
13.01 Kabelbaum zum Oberteil..... Cable tree to sewing head Ma zo de cables para el cabezal 上部机器电缆束	50
13.02 Tastschalter Push-button Inte rruptor pulsador 按钮 开关	51
13.03 Oberteilerkennung und Einschaltsperr..... Sewing head identification and start inhibitor Detección de la parte superior y bloqueo de a rranque 上部机器识别和起动闭锁	52
13.04 Einbaumotor Built-in motor Motor incorporado 内装式电机	53

	Seite Page Página 页
13 .05 Motor-Hauptschalter Main switch Interruptor principal 电机主开关	54
13 .06 Knietaster mit Leitung Knee switch with cable Interruptor de rodillera con cable 带电缆膝键	54
13 .07 Antrieb Drive Motor 驱动器	55
13 .08 Steuerungspaket Mauser Drive mit MA 40 ED-A Control package Mauser Drive with MA 40 ED-A Paquete de control Mauser Drive con MA 40 ED-A 控制组件 Mauser Drive 带 MA 40 ED-A	56
13 .09 Steuerungspaket Mauser Drive mit MA 50 ED Control package Mauser Drive with MA 50 ED Paquete de control Mauser Drive con MA 50 ED 控制组件 Mauser Drive 带 MA 50 ED	58
13 .10 Steuerungspaket Mauser Drive mit MA 350 ED Control package Mauser Drive with MA 350 ED Paquete de control Mauser Drive con MA 350 ED 控制组件 Mauser Drive 带 MA 350 ED	60
14 Garnrollenständer Reel stands Portacarretes 线轴支架	62
15 Einstellehren Adjustment gauges Calibres de ajuste 设置量规	63
16 Teile zur Tischplatte Parts for table top Piezas para el tablero 用于台板的零件	63
17 Keilriemen V-belt Correa trapezoidal 三角皮带	64
18 Knielüfterteile Knee lifter parts Piezas del alzaprensatelas por rodillera 膝松线器零件	64

	Seite Page Página 页
19 Optionen	65
Options	
Opciones	
选项	
19.01 Anbausatz für externen Motor	65
Mounting kit for external motor	
Juego de piezas acoplables para motor externo	
外部电机安装组件	
20 Schmiermittel- Übersicht	66
Overview of lubricants	
Tabla de lubricantes	
润滑剂一览	
21 Index (Teilenummern / Seitenzahlen)	67
Index (part numbers / page numbers)	
Index (números de pieza / números de página)	
注脚(零件号/页号)	
22 Unterklassen-Ausstattung	73
Subclass parts	
Composición de las subclases	
子机型-设备	
22.01 Nähwerkzeuge (MA 2081)	74
Gauge parts (MA 2081)	
Organos de costura (MA 2081)	
缝纫工具 (MA 2081)	
22.02 Nähwerkzeuge (MA 2083)	77
Gauge parts (MA 2083)	
Organos de costura (MA 2083)	
缝纫工具 (MA 2083)	



Achtung!

Wir machen ausdrücklich darauf aufmerksam, daß Ersatz- und Zubehörteile, die nicht von uns geliefert werden, auch nicht von uns geprüft und freigegeben sind. Der Einbau und / oder die Verwendung solcher Produkte kann daher u. Umständen konstruktiv vorgegebene Eigenschaften Ihrer Maschine negativ verändern. Für Schäden, die durch die Verwendung von Nicht-Originalteilen entstehen, übernehmen wir keine Haftung!



Caution!

We warn you expressively that spare parts and accessories that are not supplied by us are not tested and released by us. Fitting or using these products may therefore have negative influences on features that depend on the machine design. We are not liable for any damage caused by the use of non-original parts!



¡Atención!

Se hace observar que en el caso de piezas de recambio y accesorios que no hayan sido suministrados por nosotros, quiere decir que non han sido sometidas por nuestra parte a un control y que no se les ha dado el visto bueno. Por esta razón, el montaje y/o empleo de tales productos puede repercutir negativamente en las características previstas en su máquina. ¡Para los daños que eventualmente pudiesen presentarse al utilizar piezas no originales, no asumimos ninguna garantía!



注意!

我们必须明确指出，所有不是由我们供货的备件和附件都未经我们检查，也没有被我们批准使用。装入和/或使用这些产品可能在一定的情况下会对机器的设计特性造成负面改变。对由于使用非原装件所造成的损失，我们不负责任何责任！

- Die Seriennummer der Maschine, für die diese Teileliste Gültigkeit hat, ist auf der Titelseite aufgeführt.
 - Alle Teile sind so abgebildet, wie sie in der Maschine funktionsmäßig zusammengehören.
 - Gestrichelt dargestellte Teile zeigen angrenzende Teile aus anderen Funktionsgruppen.
 - Im oberen Teil der Bildseiten befindet sich eine Gesamtansicht der Maschine .
 - Der Einbauort der dargestellten Teile wird durch eine gerasterte Fläche gekennzeichnet.
 - Einrahmungen auf den Bildseiten zeigen, aus welchen Einzelteilen sich die Gruppenteile zusammensetzen.
 - Die auf den Bildseiten verwendeten Schlüsselzeichen (; 2 ; 3 usw.) sind im Kapitel "Erläuterungen der Schlüsselzeichen" aufgelistet.
-
- The serial number of the machine to which this parts list applies is indicated on the cover page.
 - All parts are illustrated in function groups with the parts which they function together with in the machine.
 - Parts illustrated with broken lines are parts from other function groups which border on the illustrated function group.
 - The above section of the page of illustrations contains a total view of the machine. The place for the installation of the parts pictured here is marked by the grid.
 - The framed-in sections on the illustration pages show the individual parts comprising a group.
 - The key markings used on the illustrated pages (; 2 ; 3 etc.) are listed in the chapter "Explanation of key markings".
-
- El número de serie de la máquina para la cual tiene validez esta lista de piezas va indicado en la página de título.
 - Todas las piezas están ilustradas tal como aparecen en la máquina para su funcionamiento.
 - Las piezas representadas con rayitas muestran piezas colindantes de otros grupos de funciones.
 - En la parte superior de las páginas ilustradas se puede ver una vista en conjunto de la máquina.
 - El lugar de montaje de la pieza representada va caracterizada mediante una superficie reticulada.
 - Los recuadros en las páginas ilustradas indican las piezas individuales de que se componen los grupos.
 - Los signos clave (; 2 ; 3 etc.) empleados en las páginas con ilustraciones van listados en el capítulo "Explicaciones de los signos clave".
-
- 适用于本零件表的机器系列号列在首页上。
 - 所有的零件都按照其在机器中的功能情况合在一起表达。
 - 用虚线表示的零件为相邻功能组中的零件。
 - 图的上部为机器全景。
 - 所示零件的安装部位用影格面表示。
 - 页上的框表示这套组件都由哪些零件所组成。
 - 图页上所使用的标记（ ; 2 ; 3 等）列表在“标记说明”中。

- Unterklassenabhängig, Teilenummer siehe Unterklassen-Ausstattung.**
Subclas-dependent, for part number see subclass parts listing.
Dependientes de la subclase, para el número de pieza véase "Dotación de subclases".
取决于子机型，零件号见子机型设备。
- A** **Maschinen-Ausstattung für feine Materialien.**
Model A for sewing thin and light-weight materials.
Tipo A para materiales ligeros.
用于薄料的机器设备。
- B** **Maschinen-Ausstattung für mittlere Materialien.**
Model B for sewing thin and medium-weight materials.
Tipo B para materiales semiligeros.
用于中厚料的机器设备。
- C** **Maschinen-Ausstattung für mittelschwere Materialien.**
Model C for sewing medium-heavy materials.
Tipo C para materiales semipesados.
用于中偏厚料的机器设备。
- N** **Stichlänge 6,0 mm.**
Stitch length 6.0 mm.
Largo de puntada 6,0 mm
针距6.0 mm。
- 3/1** **Gesichert mit Loctite.**
Secured with loctite.
Asegurado con Loctite.
用 Loctite 粘胶固定。
- 3/3** **Selbstklebende Folie**
Self-adhesive foil
Hoja autoadhesiva
自粘式薄膜
- 3/4** **Selbstklebend**
Self-adhesive
Autoadhesivo
自粘的
- 6** **Nadeldicke und Spitzenform bei Bestellung angeben.**
Needle size and style of point to be stated on order.
Grosor de aguja y forma de la punta, indíquese en los pedidos.
在订货时给出针厚和针尖型式。
- 27/5** **Eingeklammerte Zahl = Länge in mm.**
Number in brackets = length in mm.
Cifra entre paréntesis = largura en mm.
被括起的数字=长度，单位mm。
- 27/12** **Eingeklammerte Zahl = Durchmesser x breite in mm.**
Number in brackets = diameter x width in mm.
Cifra entre paréntesis = diámetro x anchura en mm.
被括起的数字=直径 x 宽度，单位 mm。
- 28** **Sonderausführung**
Special version
Tipo especial
特殊款式

- 35/1 Bei Montage vernieten.
 To be riveted after assembly.
 Remáchese después del montaje.
 装配时铆接
- 38/7 Kunststoffbeschichtet
 Plastic-coated
 Con revestimiento de plástico
 塑料涂层的
- 38/8 Gezahnt
 Toothed
 Dentado
 帽形齿的
- 38/9 Gerändelt
 Knurled
 Moleteado
 滚花的
- 40/1 Füllen mit 28-011 201-44; Bestellnummer siehe Seite 66.
 Top up with 28-011 201-44; for part number see page 66.
 Rellene con 28-011 201-44; para el número de pedido véase la página 66.
 注油用28-011 201-44; 订货号见第66页。
- 40/2 Tränken mit 28-011 201-44; Bestellnummer siehe Seite 66.
 Grease with 28-011 201-44; for part number see page 66.
 Engrase con grasa 28-011 201-44; para el número de pedido véase la página 66.
 浸油用28-011 201-44; 订货号见第66页。
- 40/3 Fetten mit 28-011 202-47; Bestellnummer siehe Seite 66.
 Grease with 28-011 202-47; for part number see page 66.
 Engrase con grasa 28-011 202-47; para el número de pedido véase la página 66.
 上脂用28-011 202-47; 订货号见第66页。
- 40/5 Ölen mit 28-011 201-44; Bestellnummer siehe Seite 66.
 Oil with 28-011 201-44; for part number see page 66.
 Lubrifique con grasa 28-011 201-44; para el número de pedido véase la página 66.
 上油用28-011 201-44; 订货号见第66页。
- 40/13 Fetten mit 28-011 202-05; Bestellnummer siehe Seite 66.
 Grease with 28-011 202-05; for part number see page 66.
 Graisser avec de la graisse 28-011 202-05; n de commande, voir page66.
 上脂用28-011 202-05; 订货号见第66页。
- 90/1 Für Wechselstrom
 For single-phase A.C.
 Para corriente alterna monofásica
 适用于交流电
- 90/110 Zum Bundnähen im Nahtschatten.
 For sink-stitching.
 Para pespuntear pretinas con "puntas invisibles".
 用于在接缝处缝裤腰接缝
- 90/111 Zum Bunddurchsteppen.
 For top-stitching waistbands.
 Para bien sobrecoser pretinas.
 用于裤腰绗缝
- 96 Länge angeben.
 State length.
 Indíquese la largura.
 给出长度。

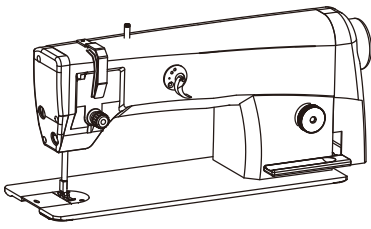

Gehäuseteile
Housing sections
Piezas del cárter MA 2081;2081-D
机身零件 MA 2083;2083-D

3.01

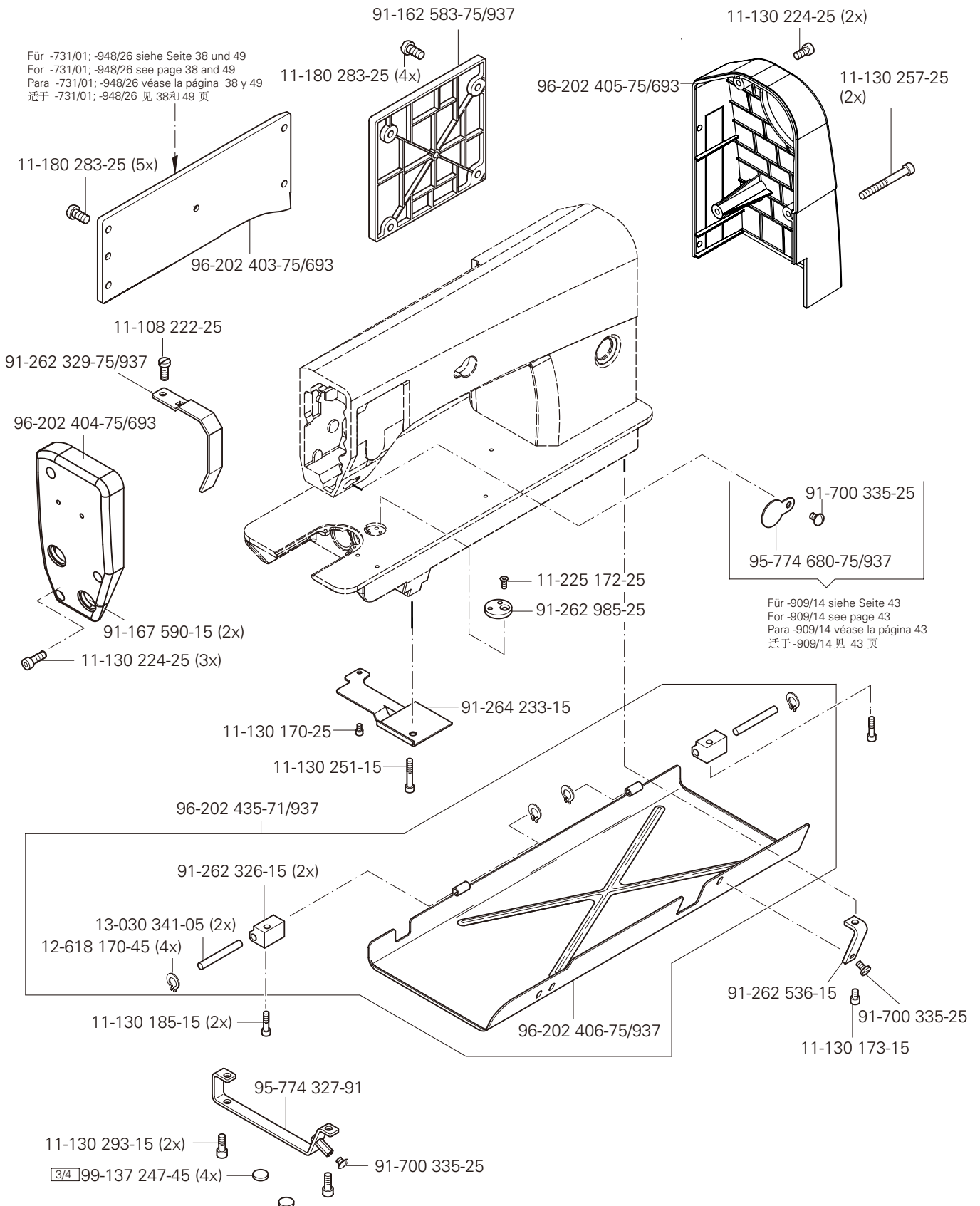

3.02

Kopfteile Needle head parts Piezas de la cabeza 机头零件

MA 2081;2081-D
MA 2083;2083-D

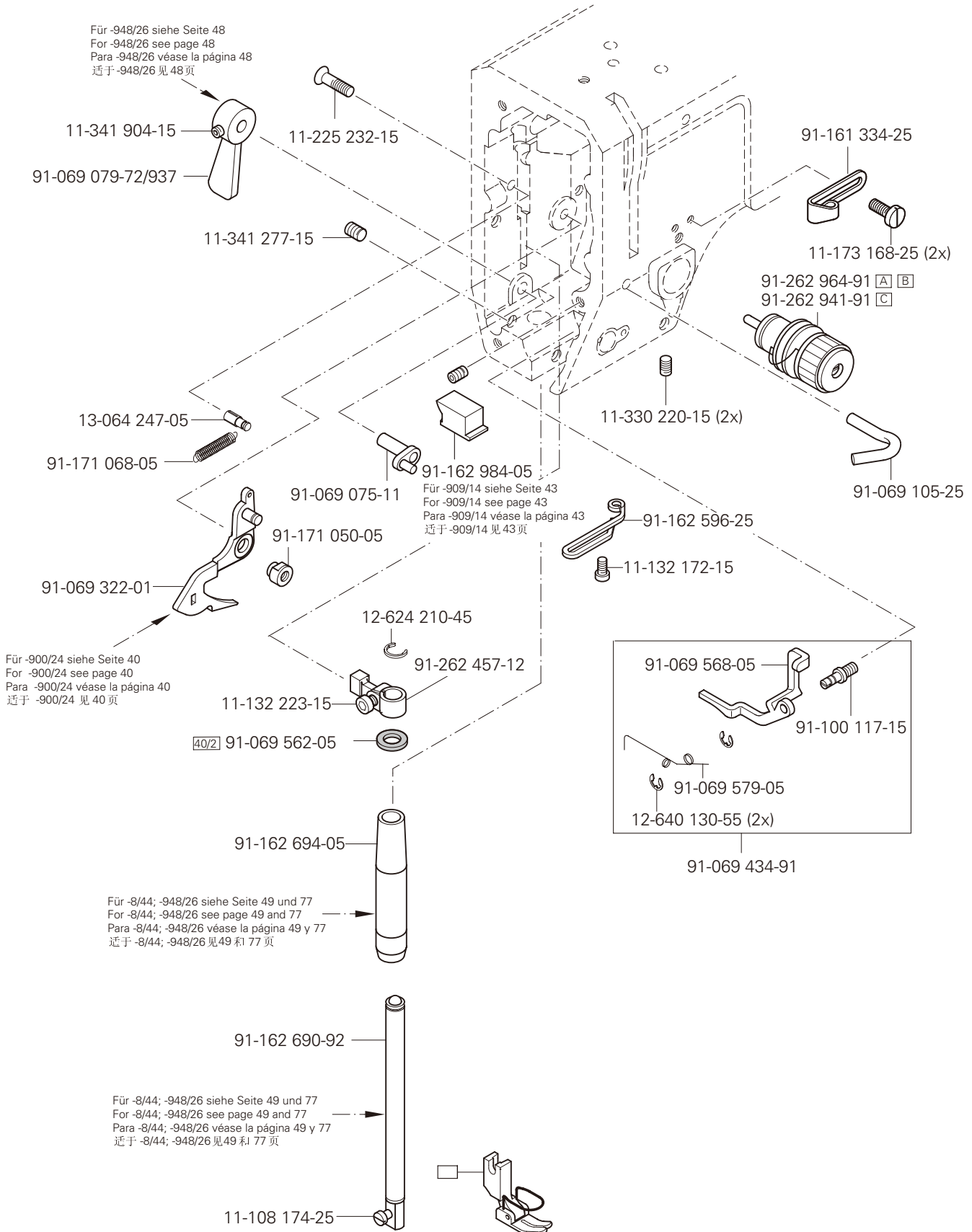
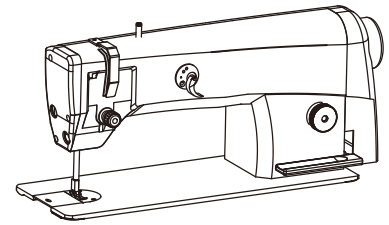

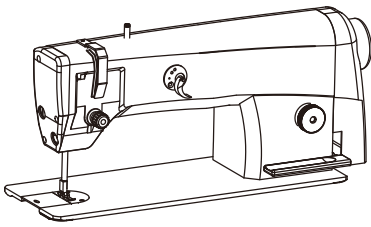

Kopfteile
Needle head parts
Piezas de la cabeza MA 2081;2081-D
机头零件 MA 2083;2083-D

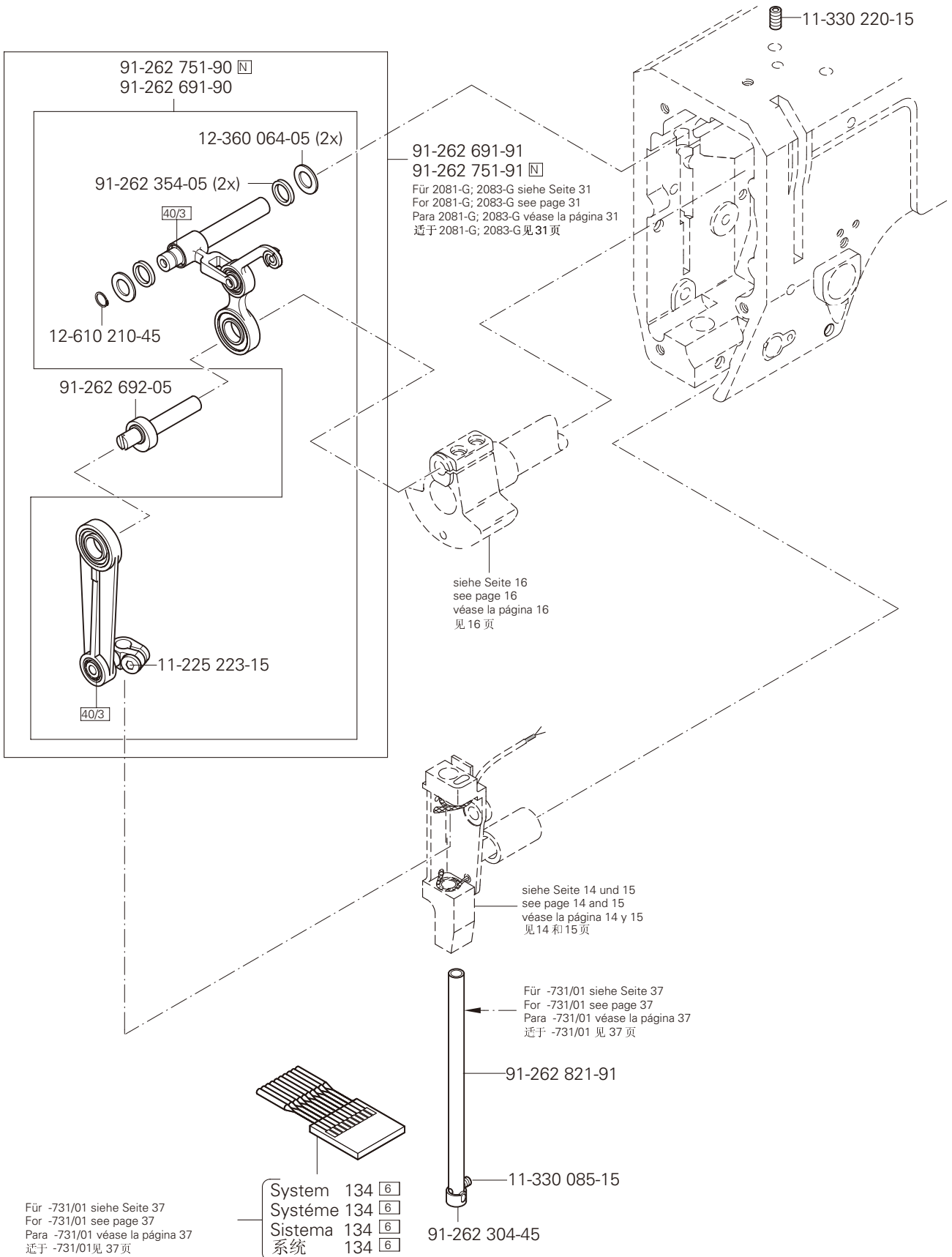

siehe Kapitel 2 Erläuterung der Schlüsselzeichen
 see chapter 2 Explanation of key markings
 véase el Cap. 2 Explicaciones de los signos clave
 见第2章标记说明

3.02

Kopfteile
Needle head parts
Piezas de la cabeza
机头零件

MA 2081;2081- D

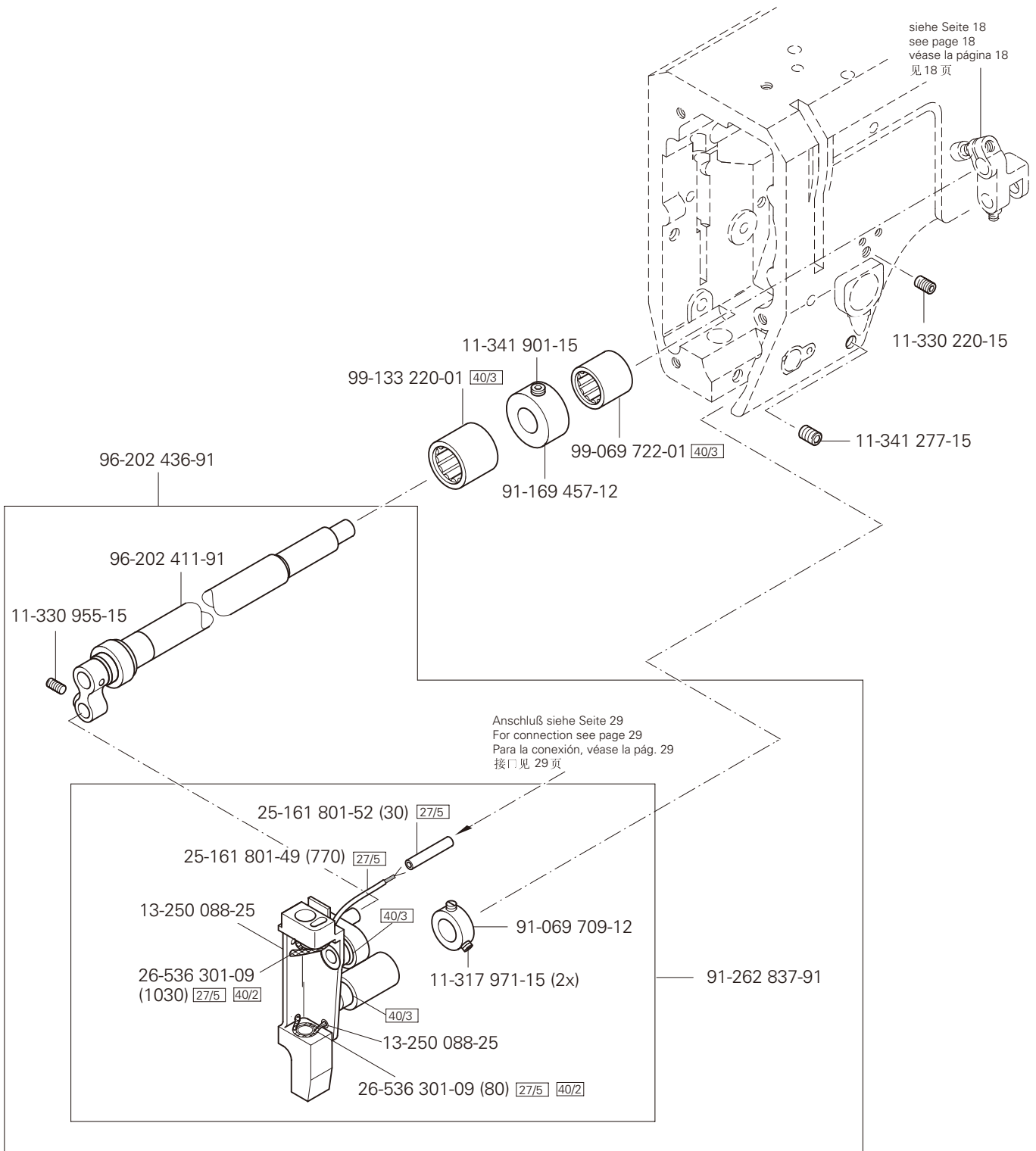
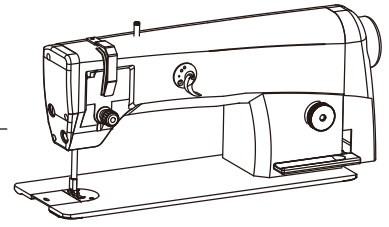

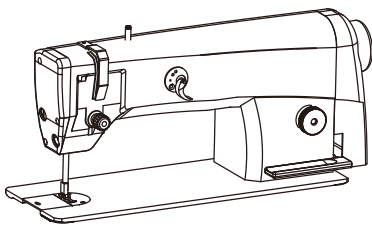

Kopfteile
Needle head parts
Piezas de la cabeza
机头零件

MA 2083 ; 2083-D

3.02

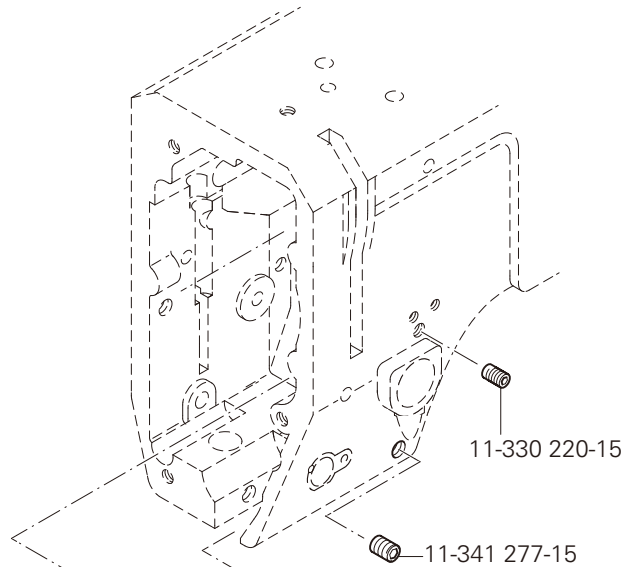

siehe Seite 13
see page 13
véase la página 13
见13页

Anschluß siehe Seite 29
For connection see page 29
Para la conexión, véase la pág. 29
接1见29页

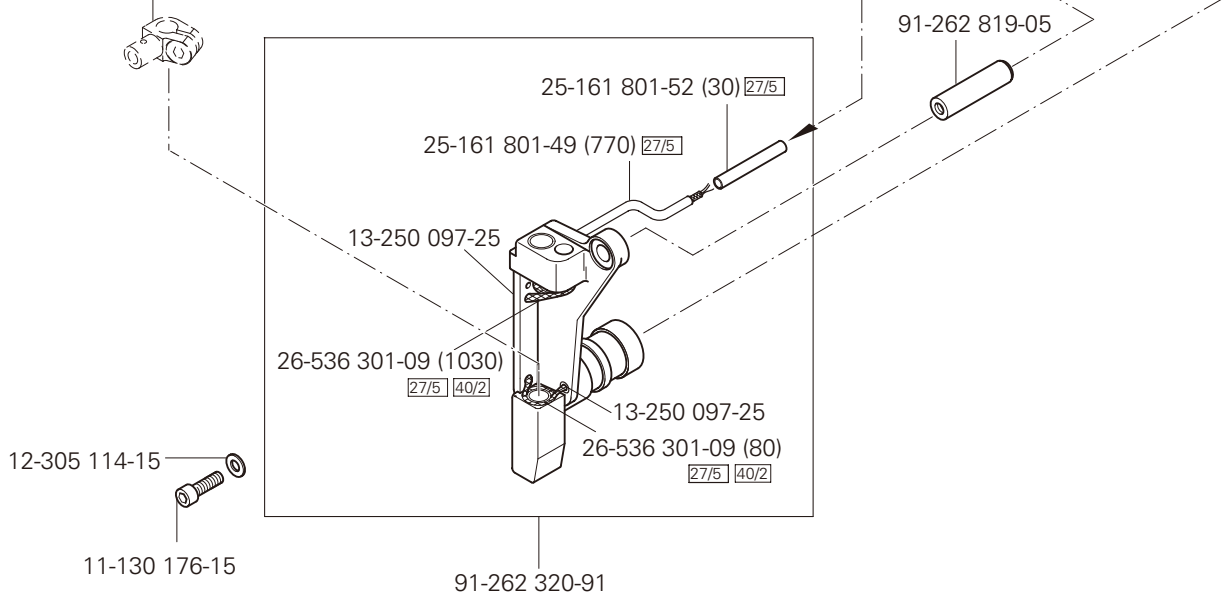

3.03

Armteile
 Arm parts
 Piezas del brazo
 机臂零件

MA 2081;2081-D
 MA 2083;2083-D

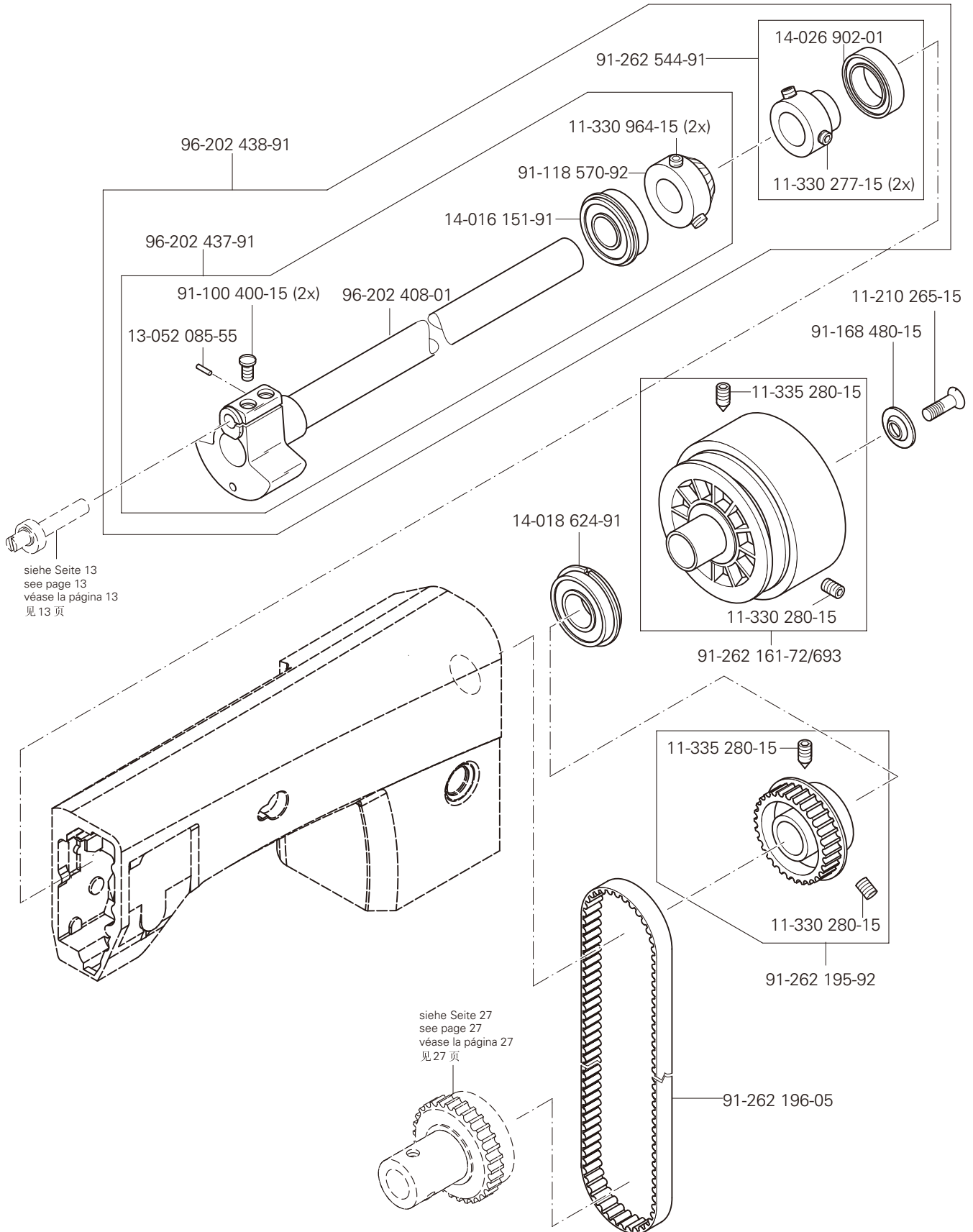
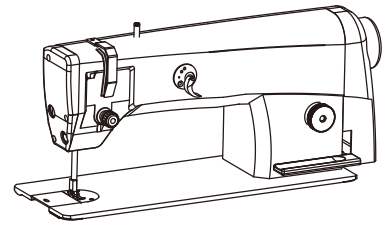

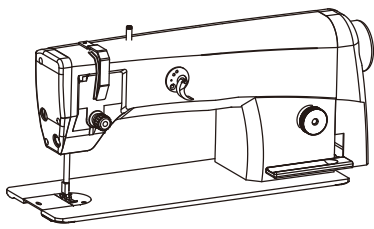

Armteile

Arm parts

Piezas del brazo MA 2081;2081-D

机臂零件

MA 2083;2083-D

3.03

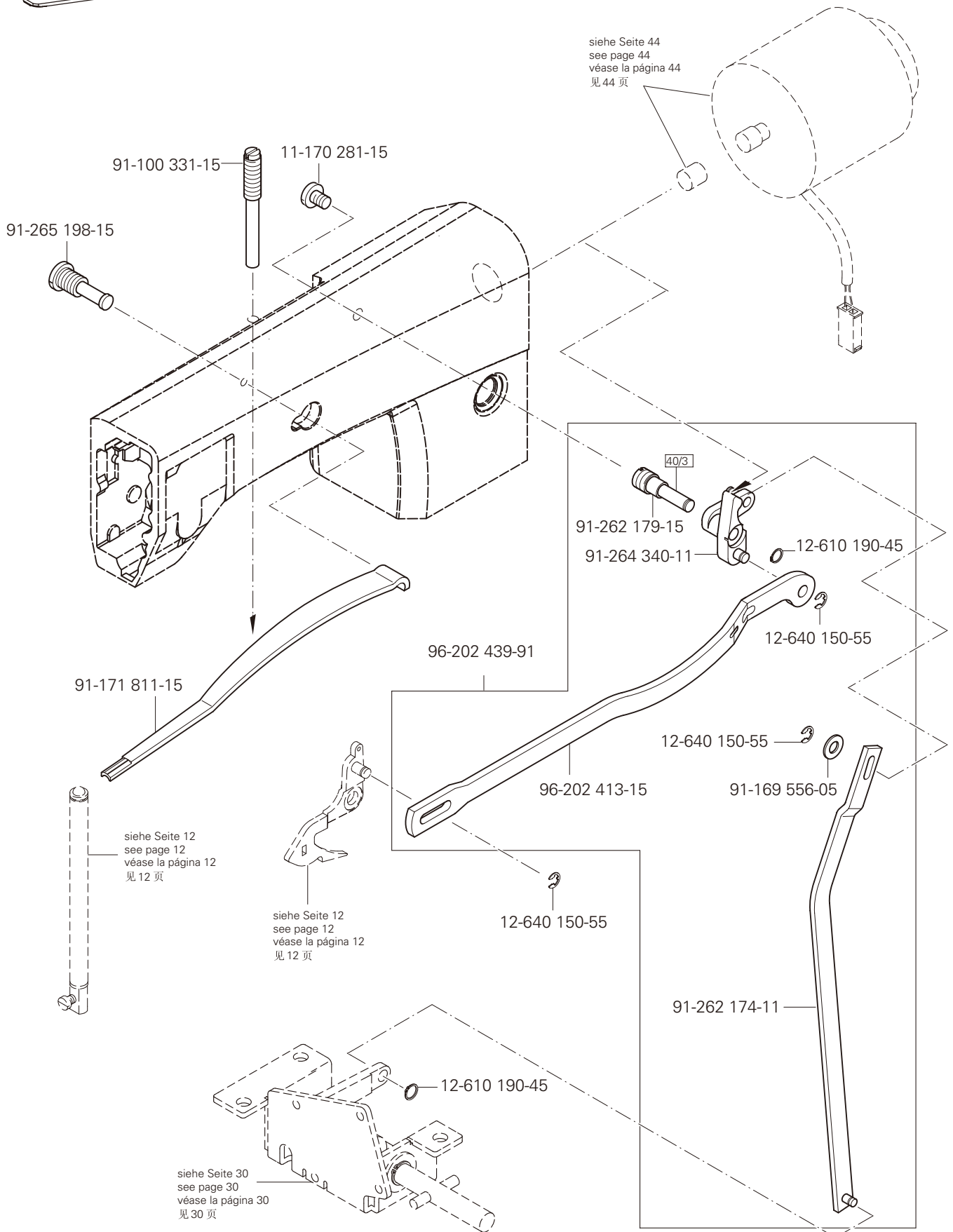

3.03

Armteile
 Arm parts
 Piezas del brazo
 机臂零件

MA 2081;2081- D

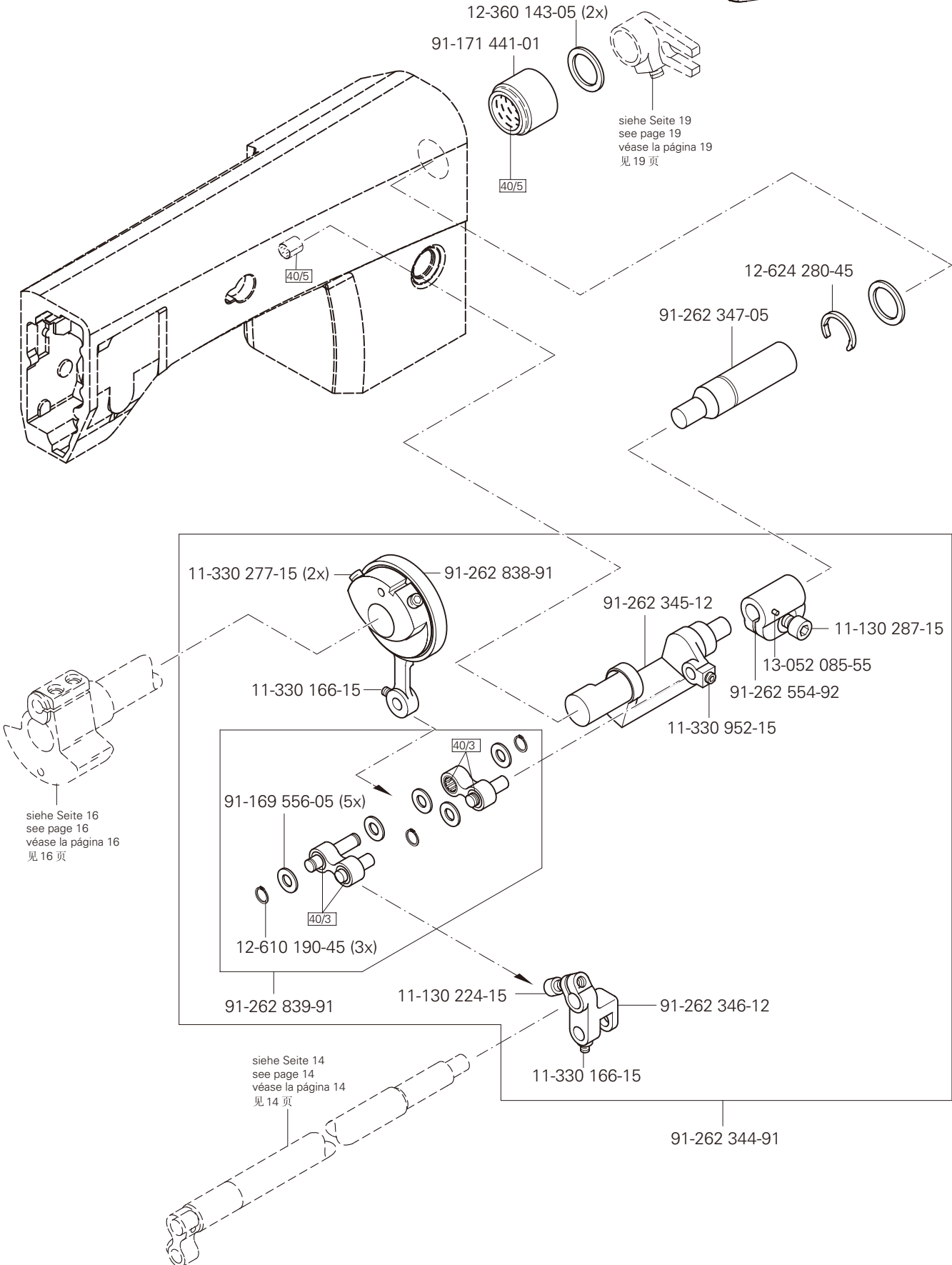
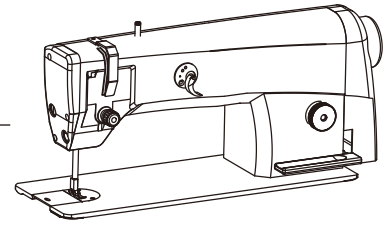

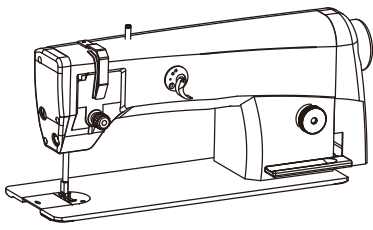

Armteile
 Arm parts
 Piezas del brazo
 机臂零件

MA 2081;2081-D

3.03

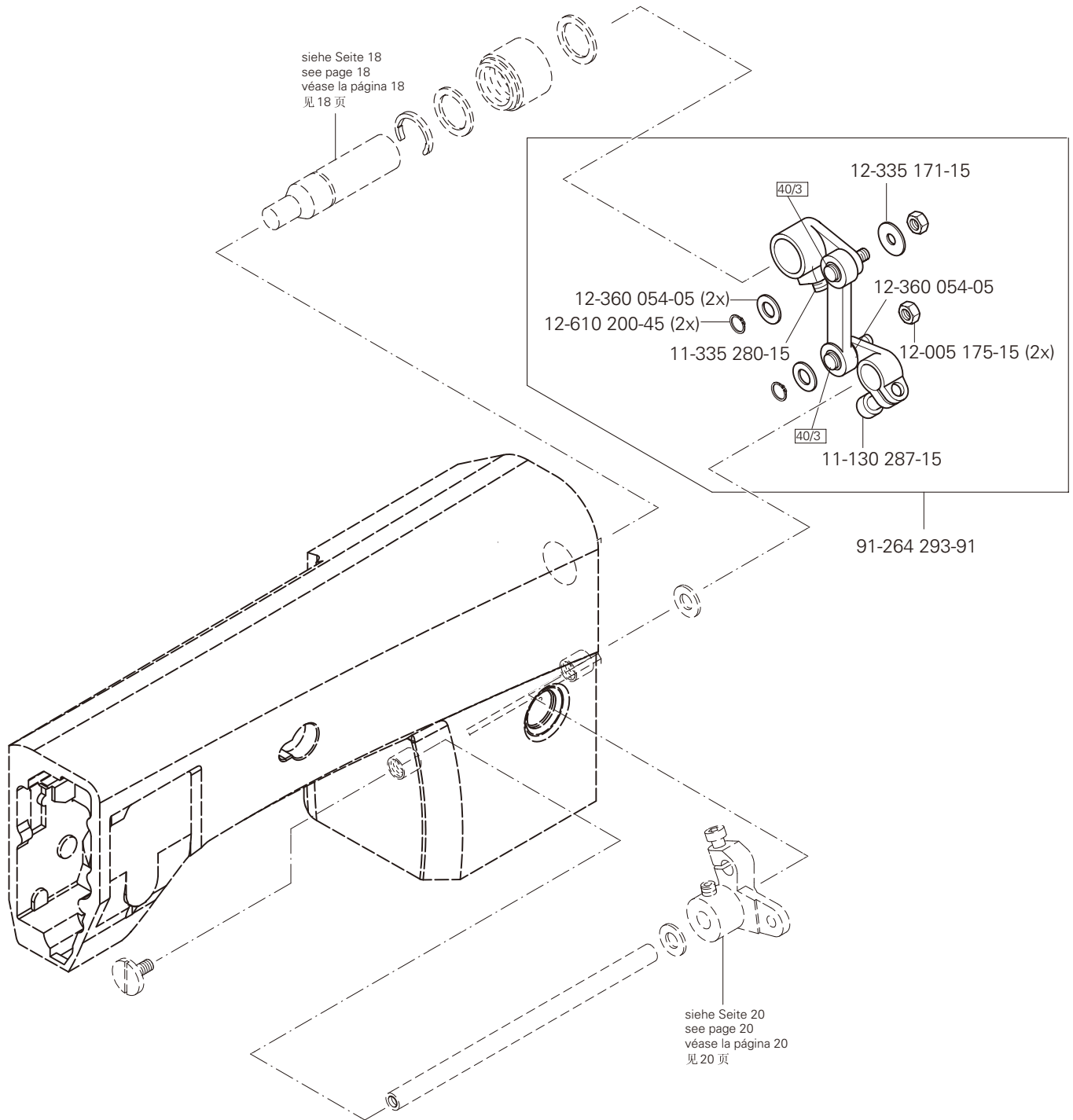

3.03

Armteile
 Arm parts
 Piezas del brazo MA 2081;2081-D
 机臂零件 MA 2083;2083-D

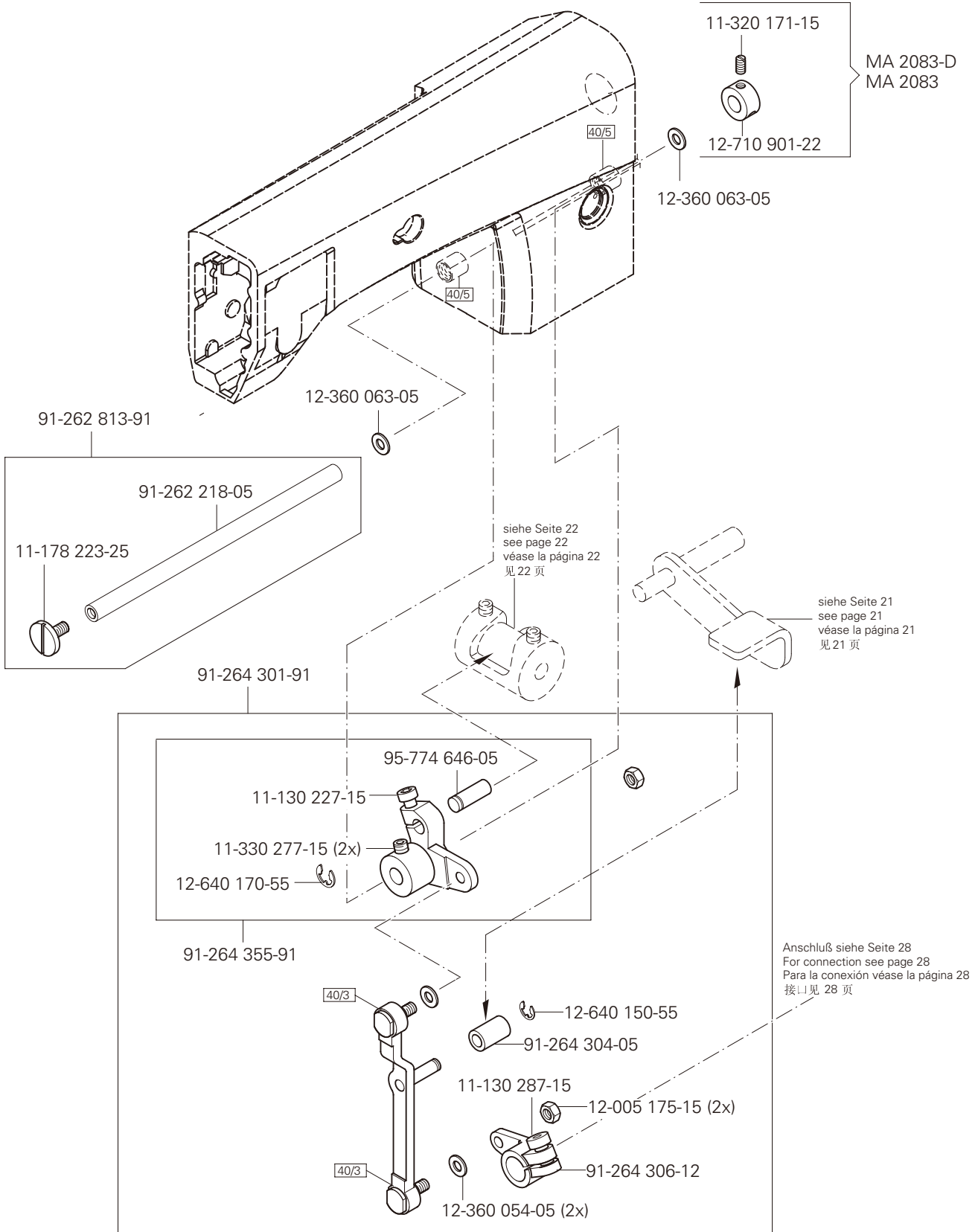
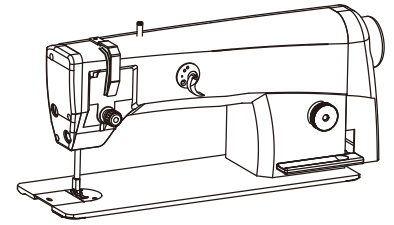

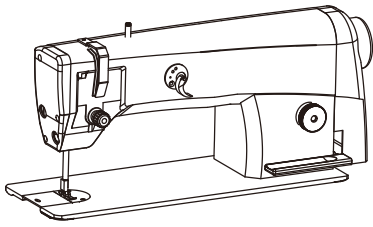

Armteile
 Arm parts
 Piezas del brazo
 机臂零件

MA 2081;2081-D
 MA 2083;2083-D

3.03

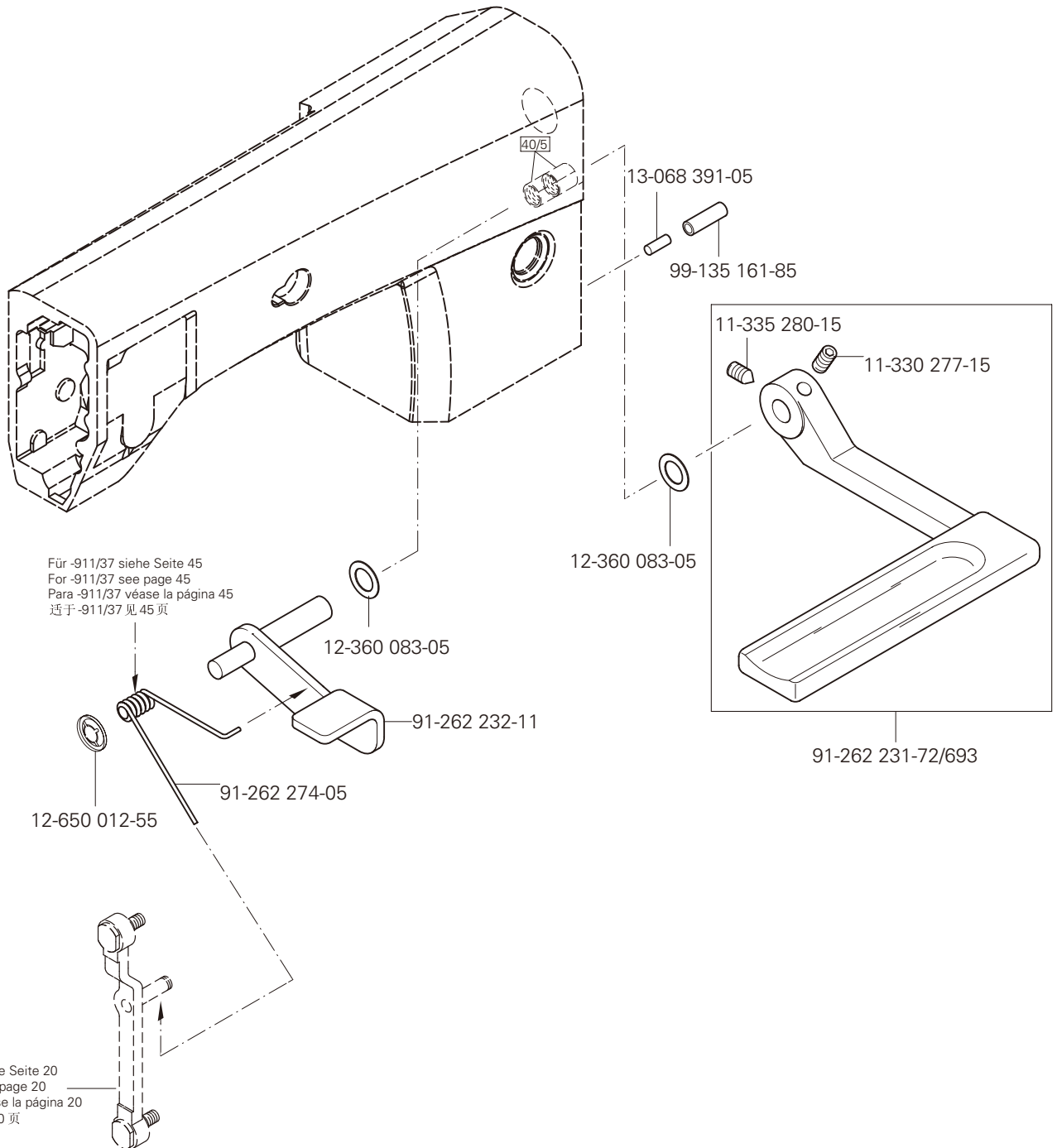

3.03

Armteile
 Arm parts
 Piezas del brazo
 机臂零件

MA 2081;2081-D
 MA 2083;2083-D

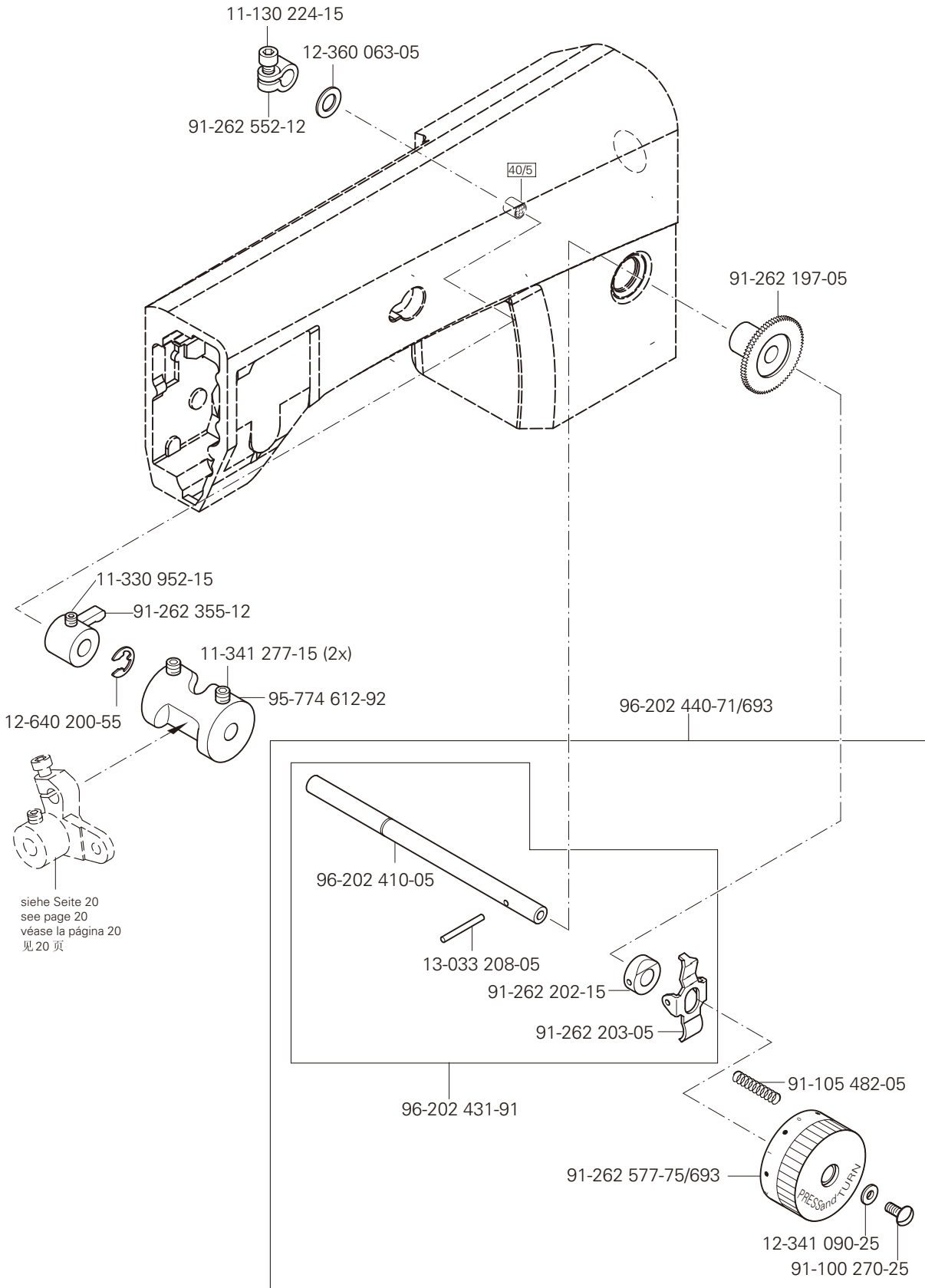
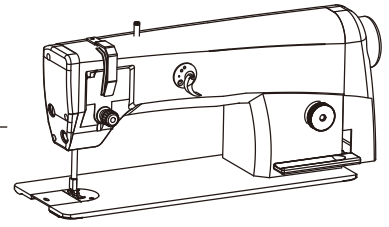

siehe Seite 20
 see page 20
 véase la página 20
 见 20 页

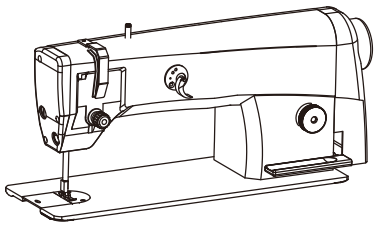

Armteile
 Arm parts
 Piezas del brazo
 机臂零件

MA 2081;2081-D
 MA 2083;2083-D

3.03

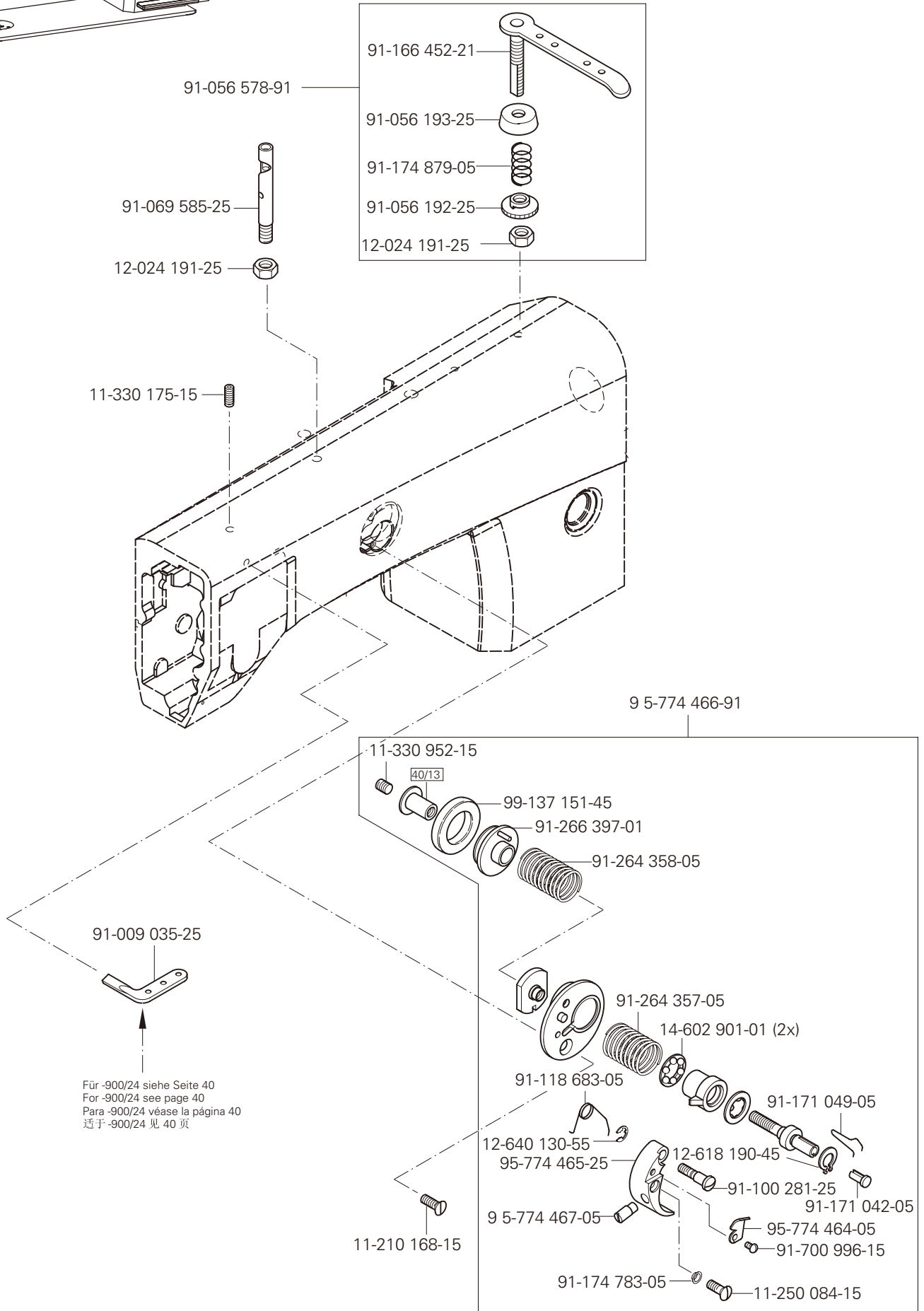

☐ siehe Kapitel 2 Erläuterung der Schlüsselzeichen
 see chapter 2 Explanation of key markings
 véase el Cap. 2 Explicaciones de los signos clave
 见第2章标记说明

3.04

Grundplattenteile
Bedplate parts
Piezas del cárter
底板零件

MA 2081;2081-D
MA 2083;2083-D

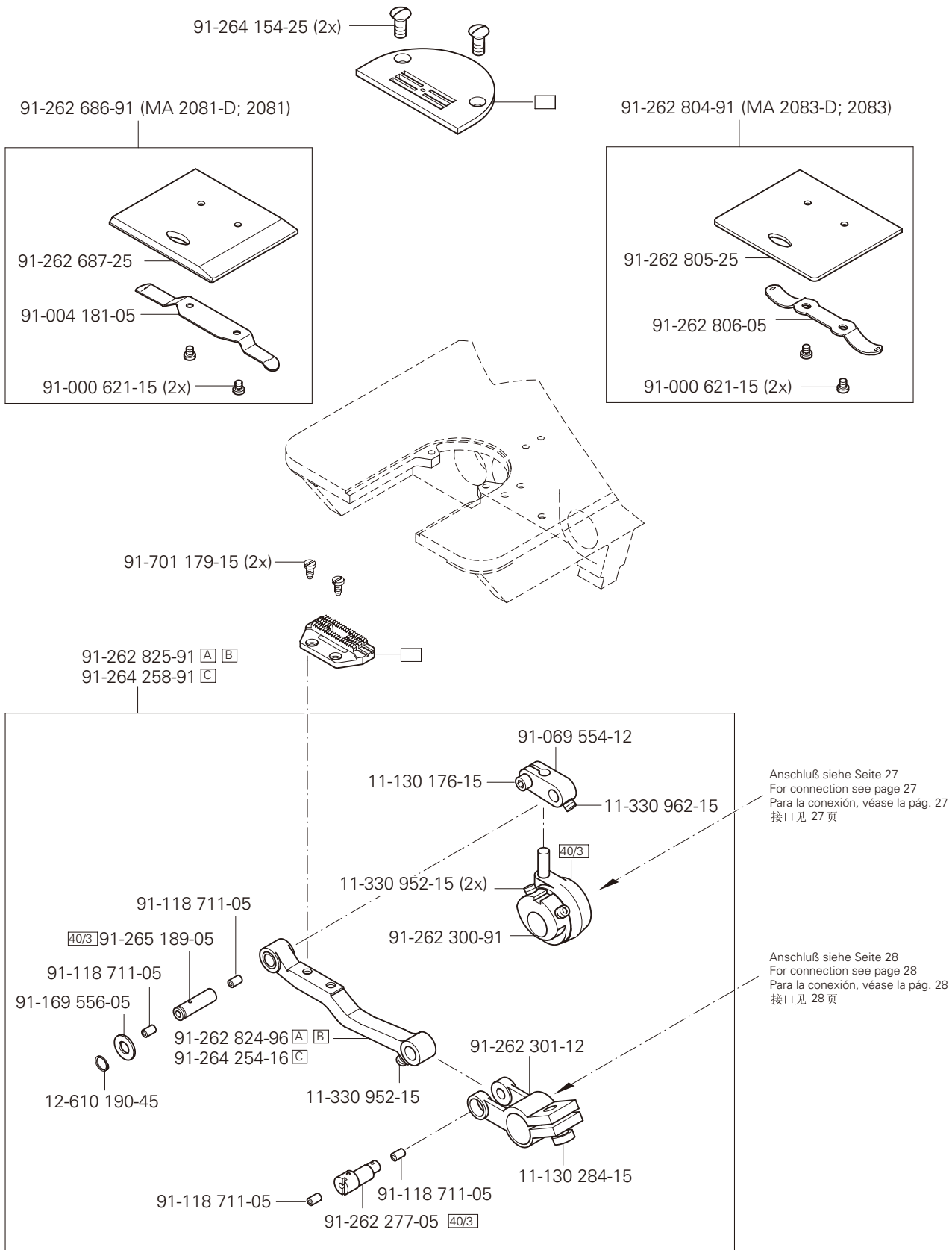
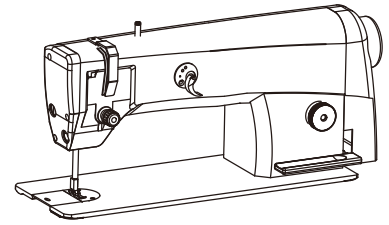

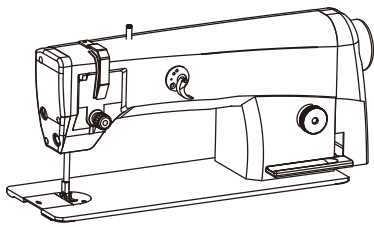

Grundplattenteile

Bedplate parts

Piezas del cárter MA 2081-D

底板零件

MA 2081-D

MA 2083-D

3.04

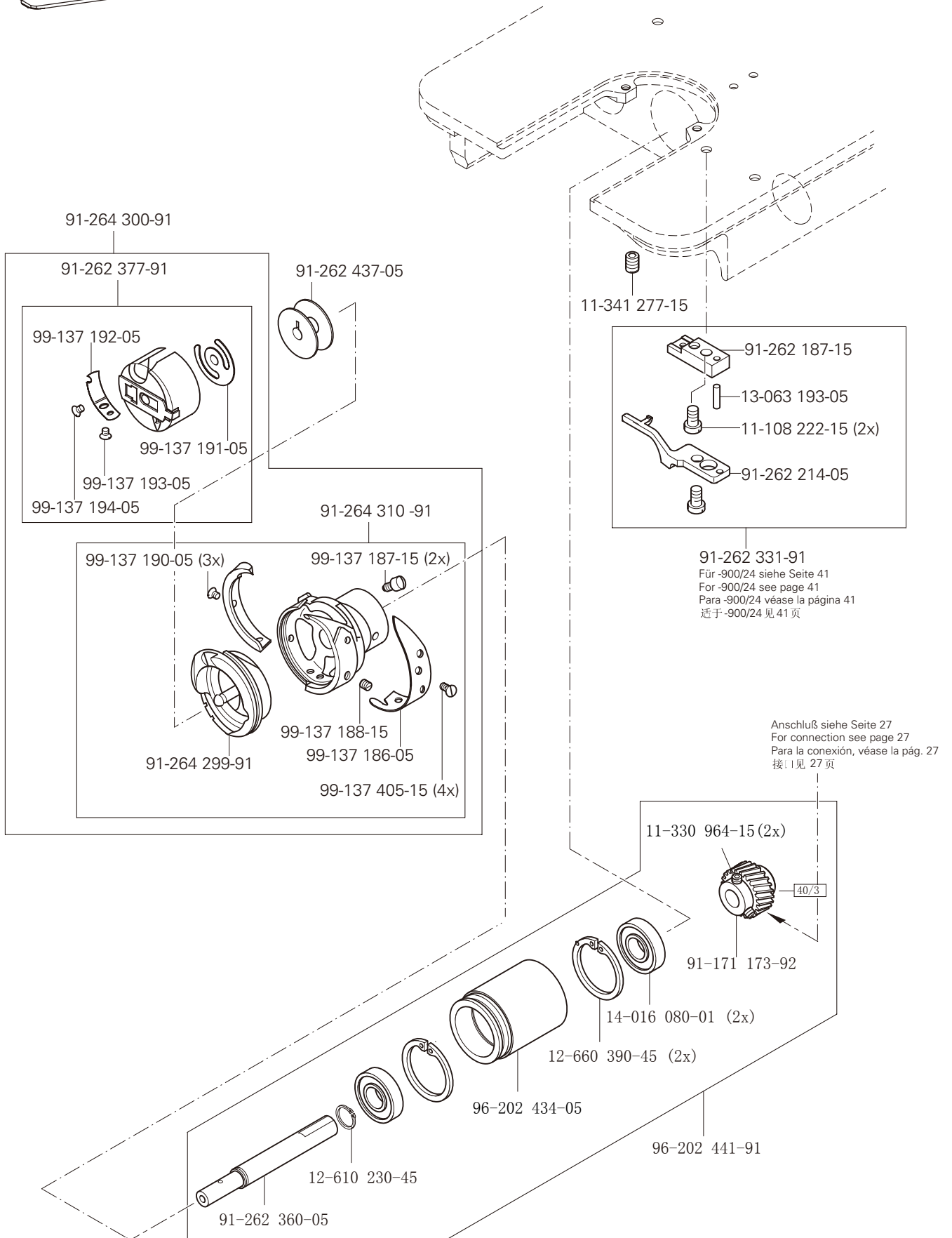

siehe Kapitel 2 Erläuterung der Schlüsselzeichen
 see chapter 2 Explanation of key markings
 véase el Cap. 2 Explicaciones de los signos clave
 见第2章标记说明

3.04

Grundplattenteile Bedplate parts Piezas del cárter 底板零件

MA 2081
MA 2083

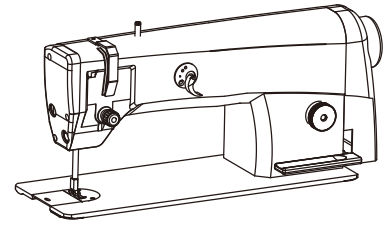

91-262 250-91 **A** **B**

Für 2081-G; 2083-G siehe Seite 32
For 2081-G; 2083-G see page 32
Para 2081-G; 2083-G véase la página 32
适于 2081-G; 2083-G 见 32 页

91-262 437-05

Für 2081-G; 2083-G siehe Seite 32
For 2081-G; 2083-G see page 32
Para 2081-G; 2083-G véase la página 32
适于 2081-G; 2083-G 见 32 页

91-264 383-91 **C**

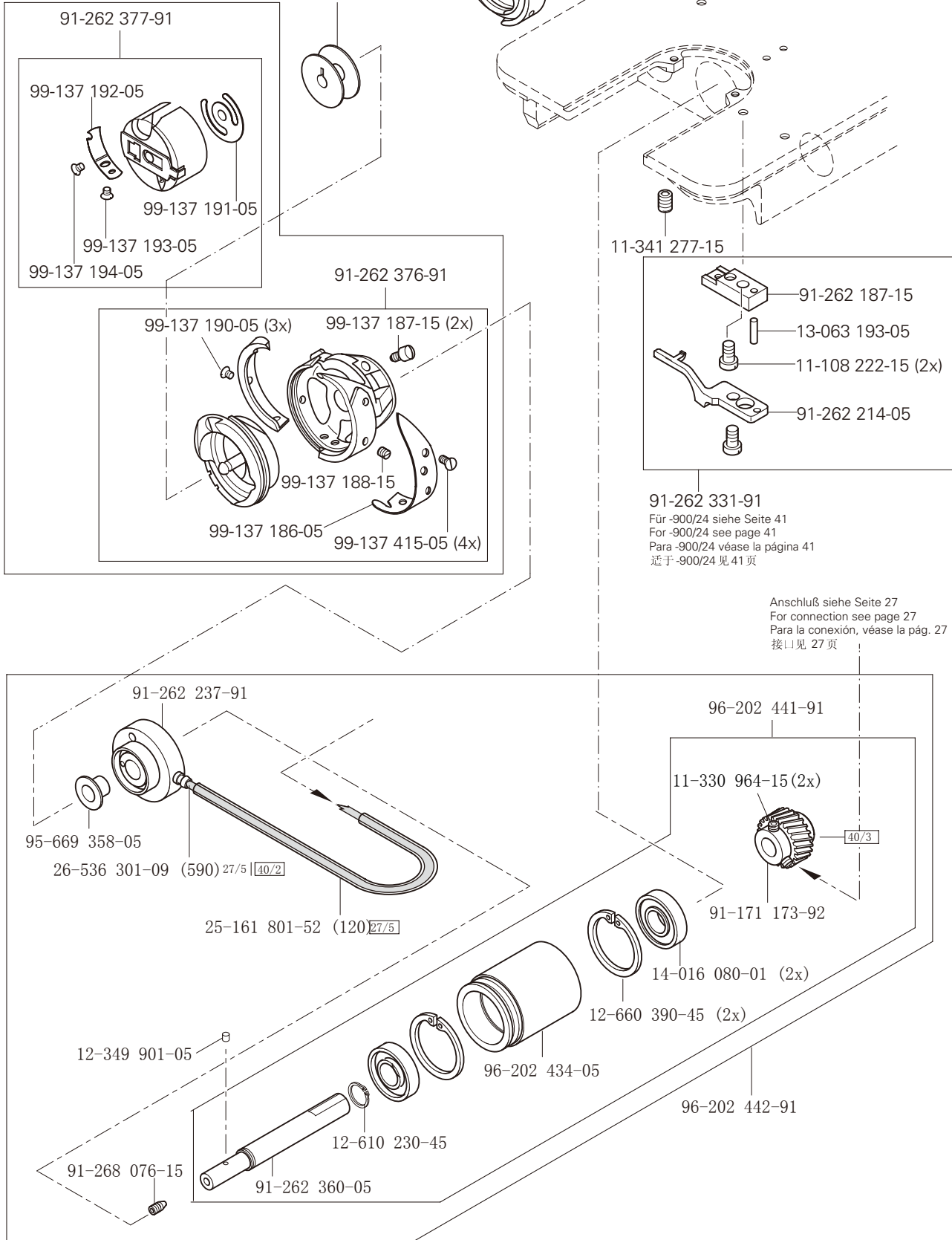
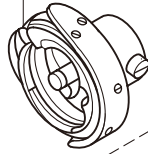

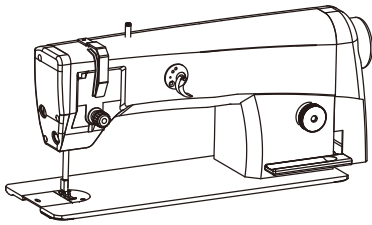

Grundplattenteile
 Bedplate parts
 Piezas del cárter MA 2081;2081-D
 底板零件 MA 2083;2083-D

3.04

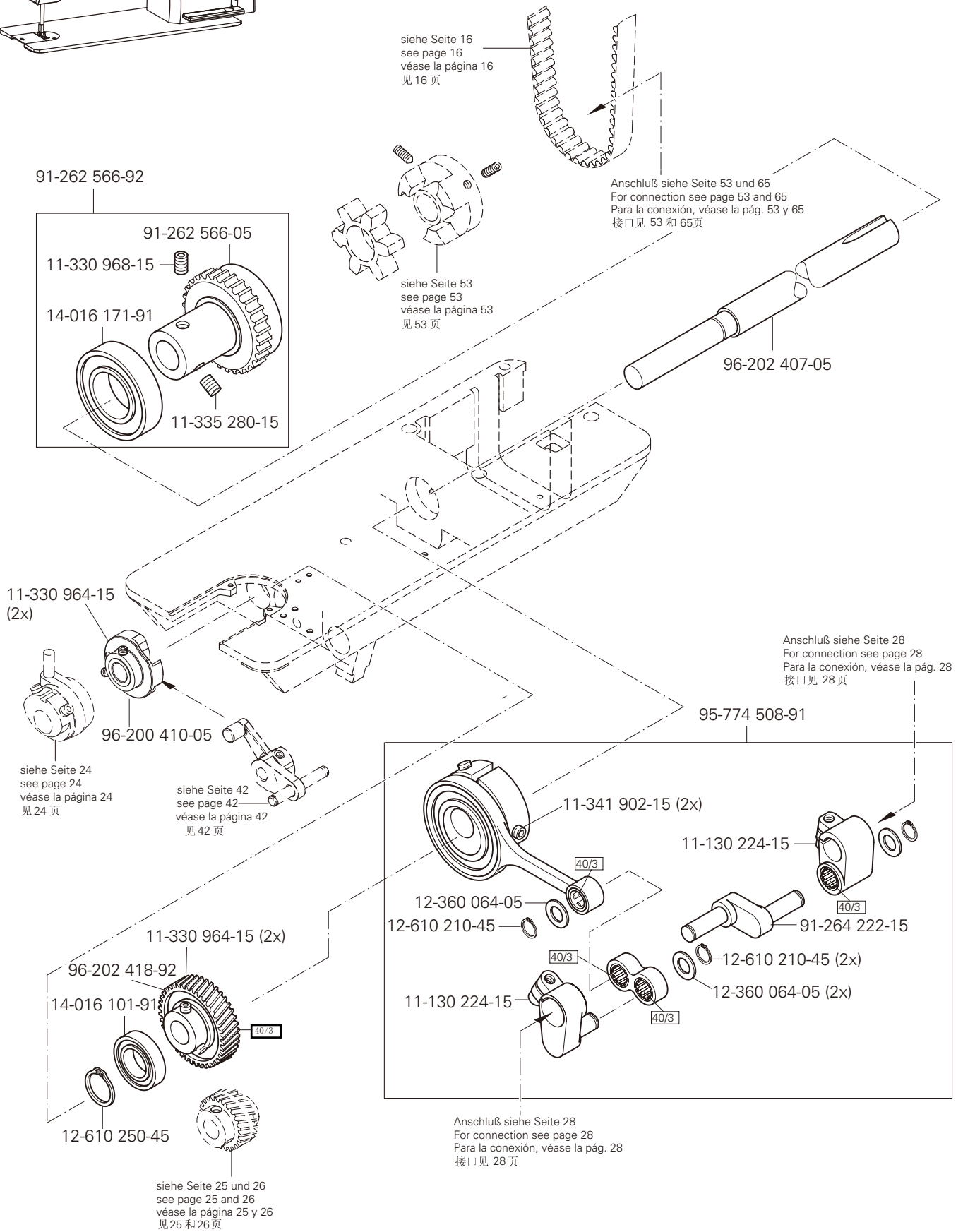

3.04

Grundplattenteile
Bedplate parts
Piezas del cárter
底板零件

MA 2081;2081-D
MA 2083;2083-D

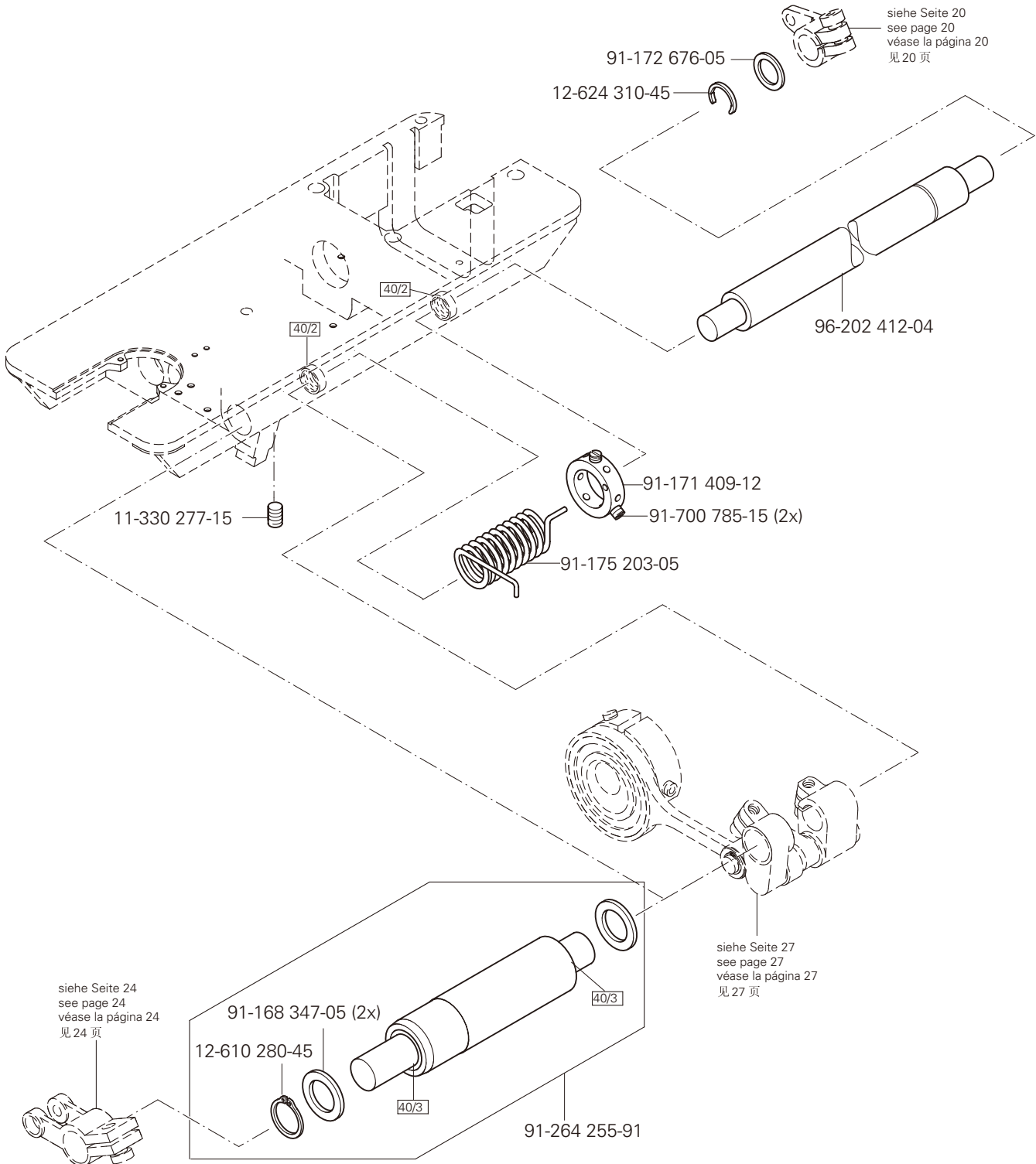
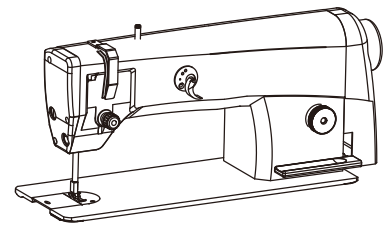

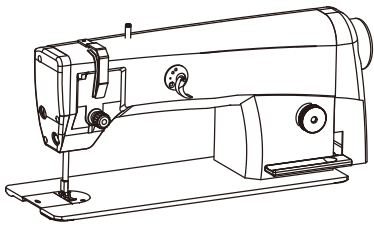

Grundplattenteile
Bedplate parts
Piezas del cárter
底板零件

MA 2081
MA 2083

3.04

siehe Seite 14 und 15
see page 14 and 15
véase la página 14 y 15
见14和15页

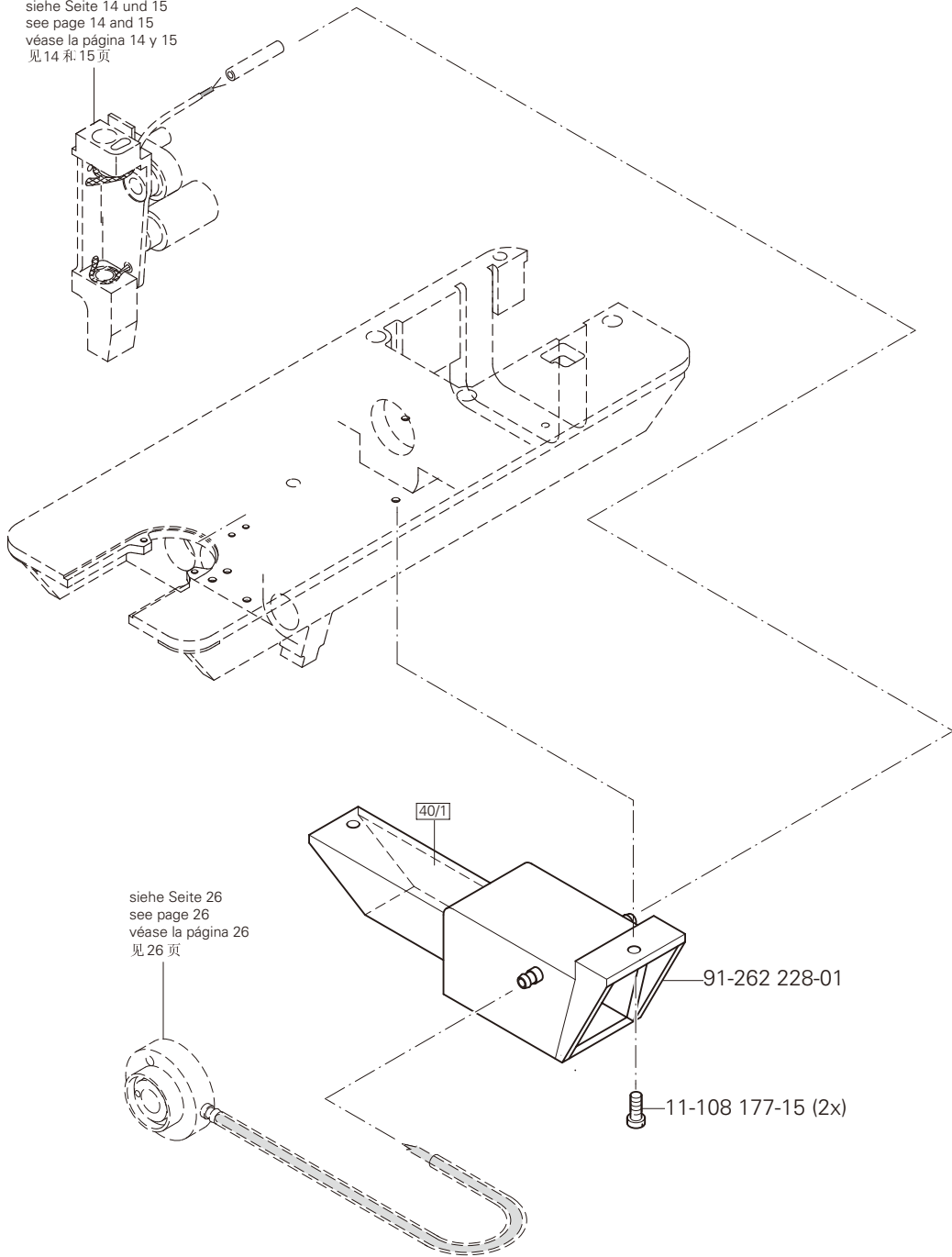

siehe Seite 26
see page 26
véase la página 26
见26页

40/1

91-262 228-01

11-108 177-15 (2x)

3.04

Grundplattenteile
Bedplate parts
Piezas del cárter
底板零件

MA 2081;2081- D
MA 2083;2083- D

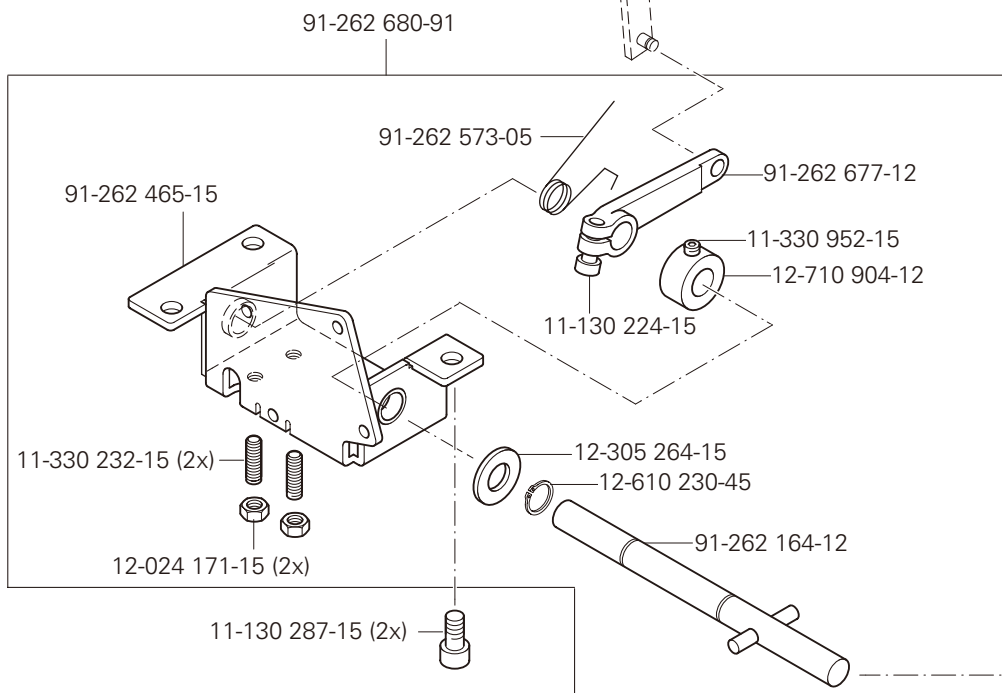
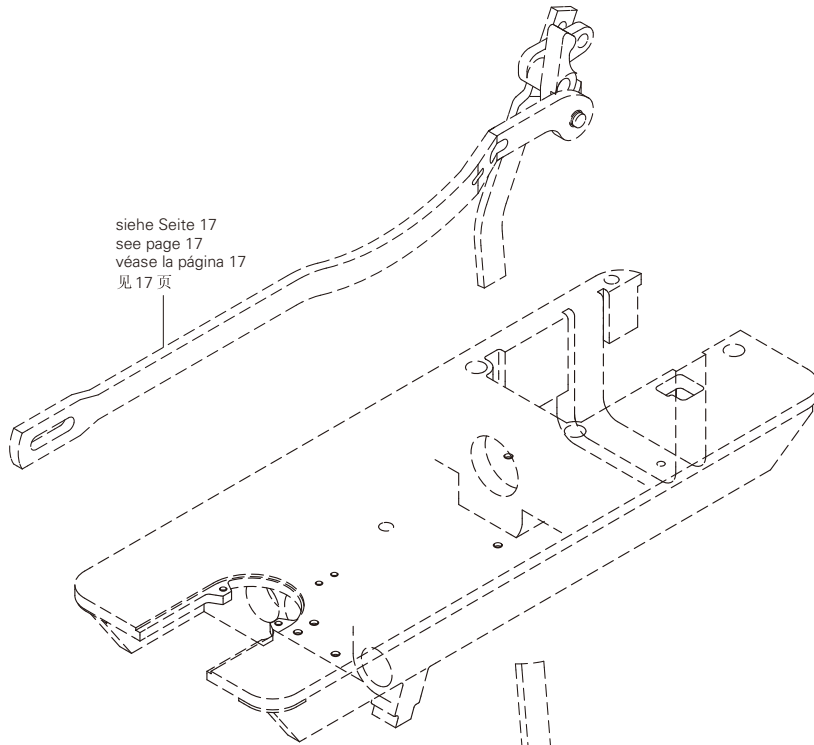
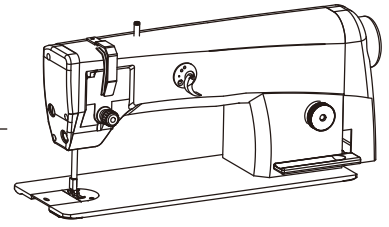

Anschluß siehe Seite 64
For connection see page 64
Para la conexión, véase la pág. 64
接 64 页

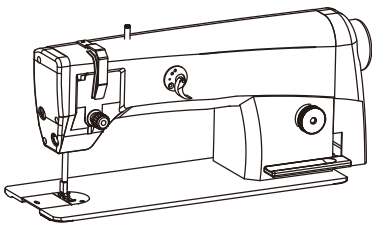

Abweichende Teile der MA 2081-G;2083-G
 Different parts for MA 2081-G;2083-G
 Piezas de la MA 2081-G;2083-G que son diferentes
 MA 2081-G;2083-G 中有差别的零件

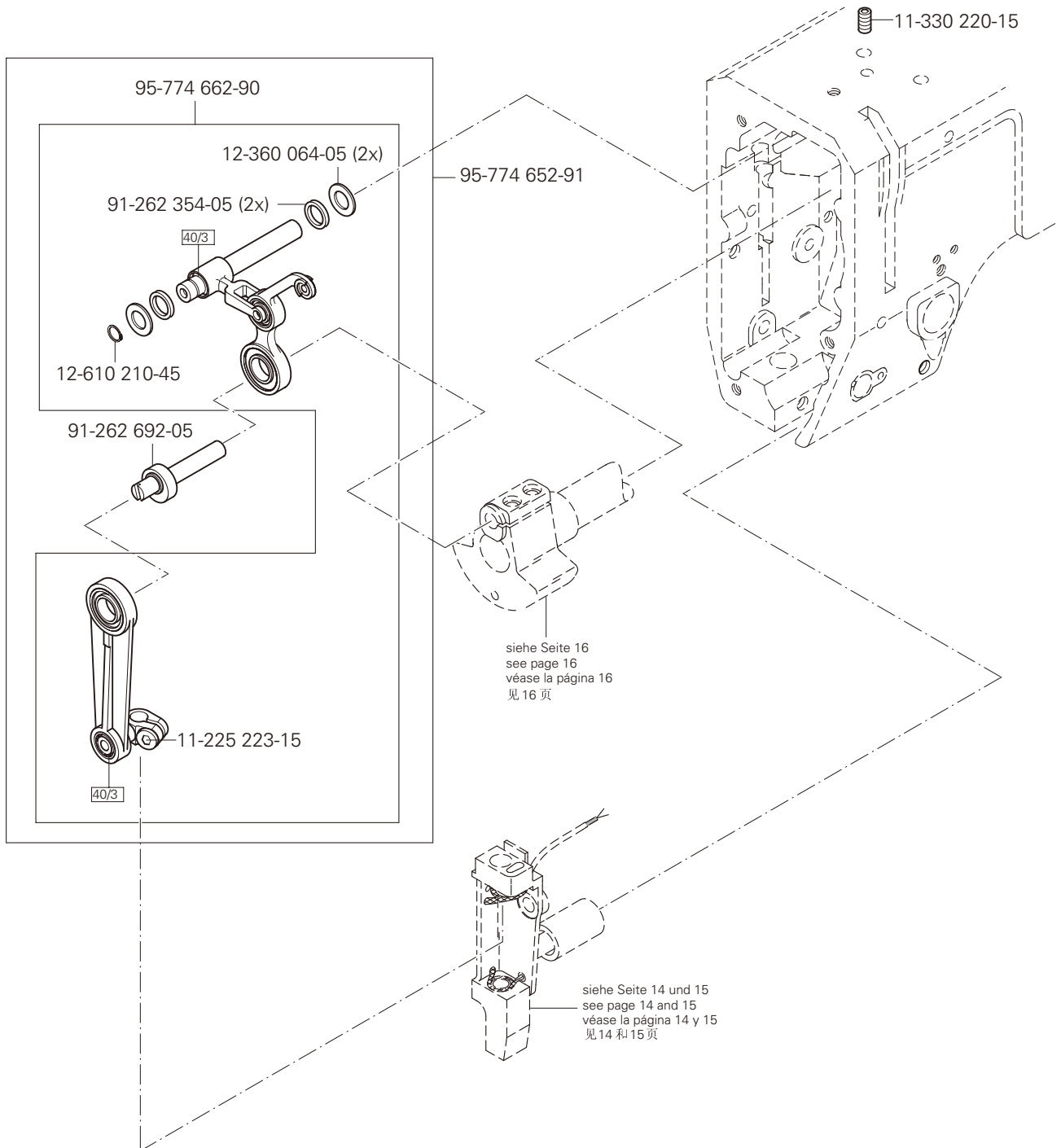

□ siehe Kapitel 2 Erläuterung der Schlüsselzeichen
 see chapter 2 Explanation of key markings
 véase el Cap. 2 Explicaciones de los signos clave
 见第2章标记说明

(die sonstigen Teile wie in Register 3.01 bis 3.04)
 (for all other parts see Sections 3.01 to 3.04)
 (las demás piezas como en los registros 3.01 al 3.04)
 (其它零件与3.01至3.04章中的相同)

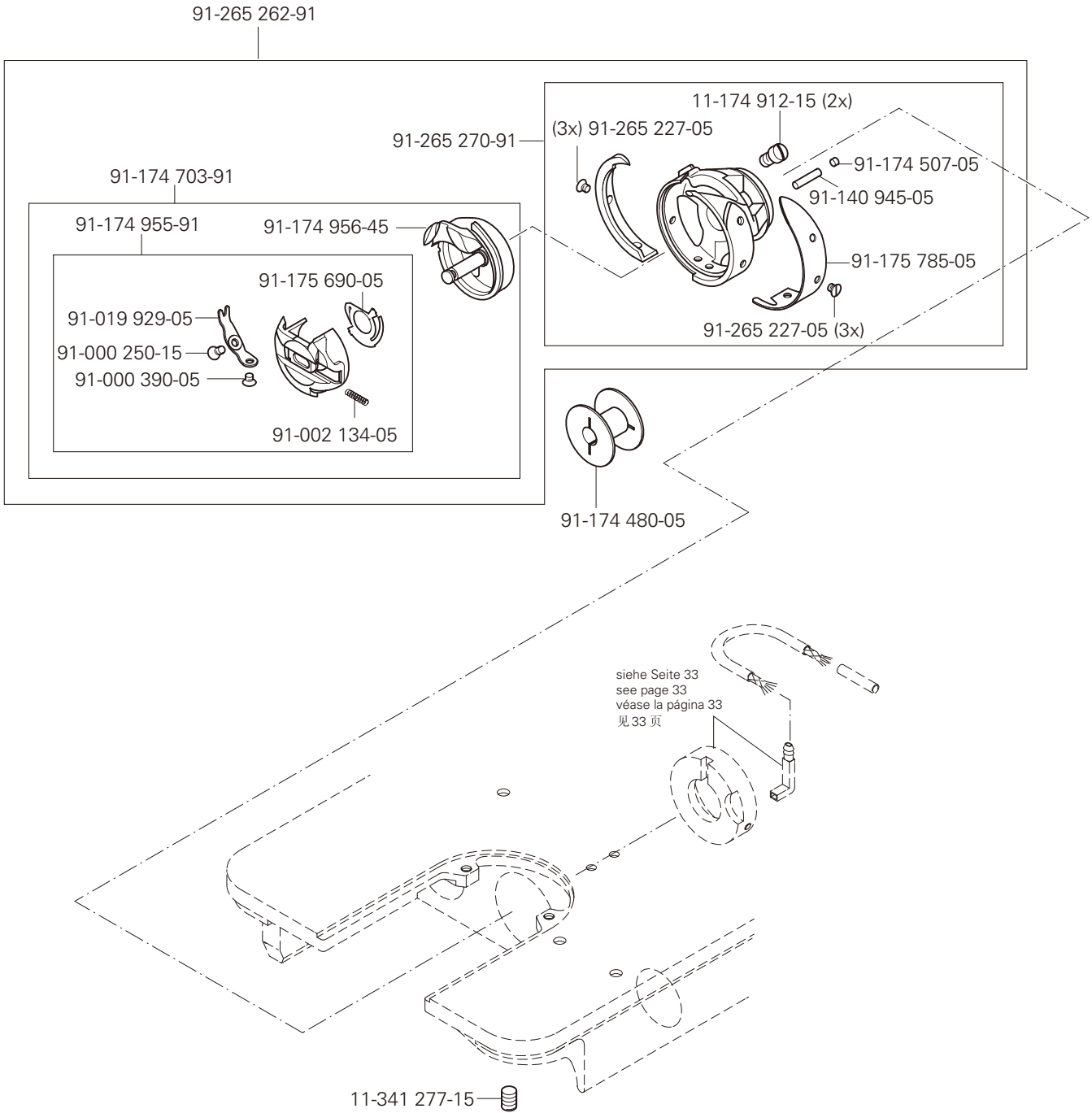
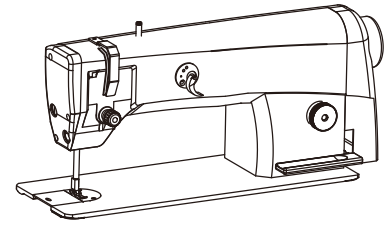

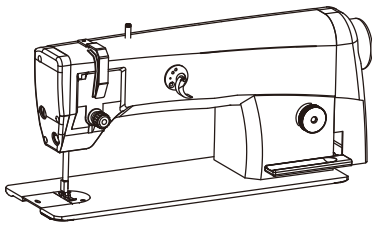

Abweichende Teile der MA 2081-G;2083-G
 Different parts for MA 2081-G;2083-G
 Piezas de la MA 2081-G;2083-G que son diferentes
 MA 2081-G;2083-G 中有差别的零件

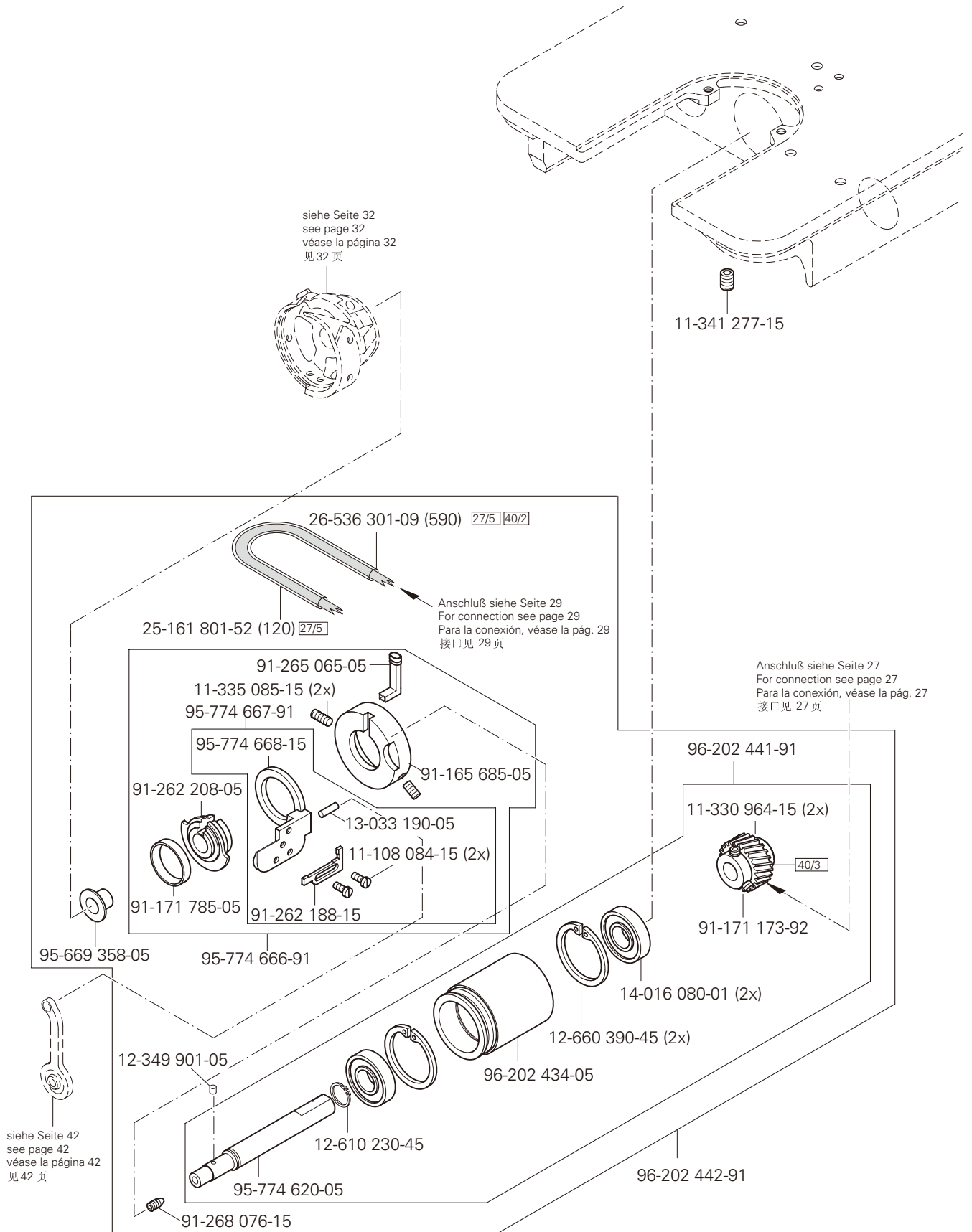

siehe Kapitel 2 Erläuterung der Schlüsselzeichen
 see chapter 2 Explanation of key markings
 véase el Cap. 2 Explicaciones de los signos clave
 见第2章标记说明

(die sonstigen Teile wie in Register 3.01 bis 3.04)
 (for all other parts see Sections 3.01 to 3.04)
 (las demás piezas como en los registros 3.01 al 3.04)
 (其它零件与3.01至3.04章中的相同)

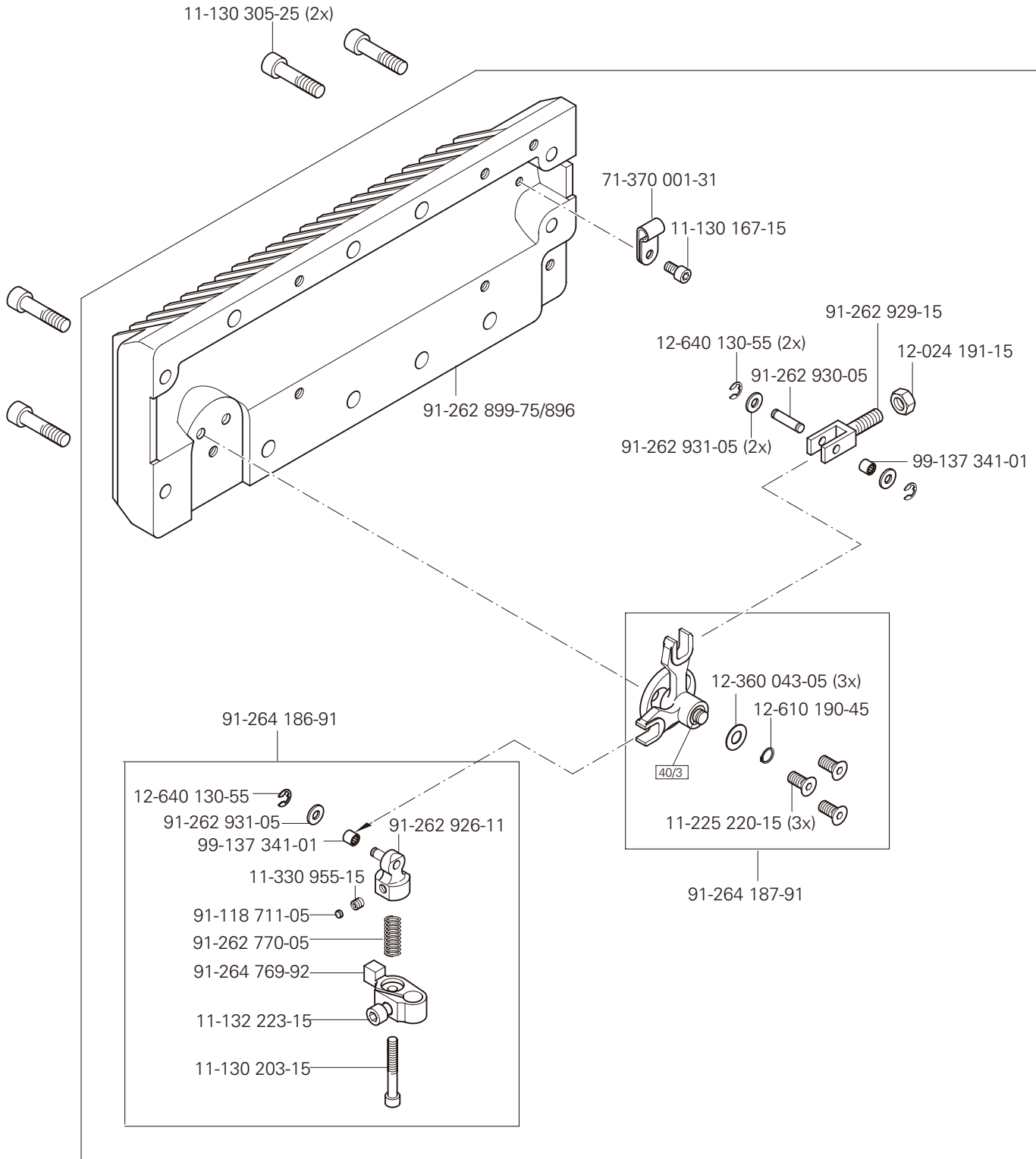
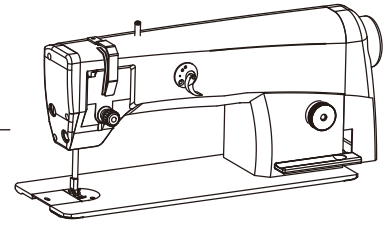

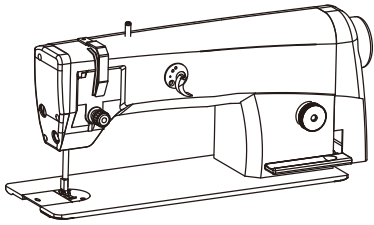

SRP
SRP
SRP
SRP

MA 2081-900/24
MA 2083-900/24

91-264 189-71/896

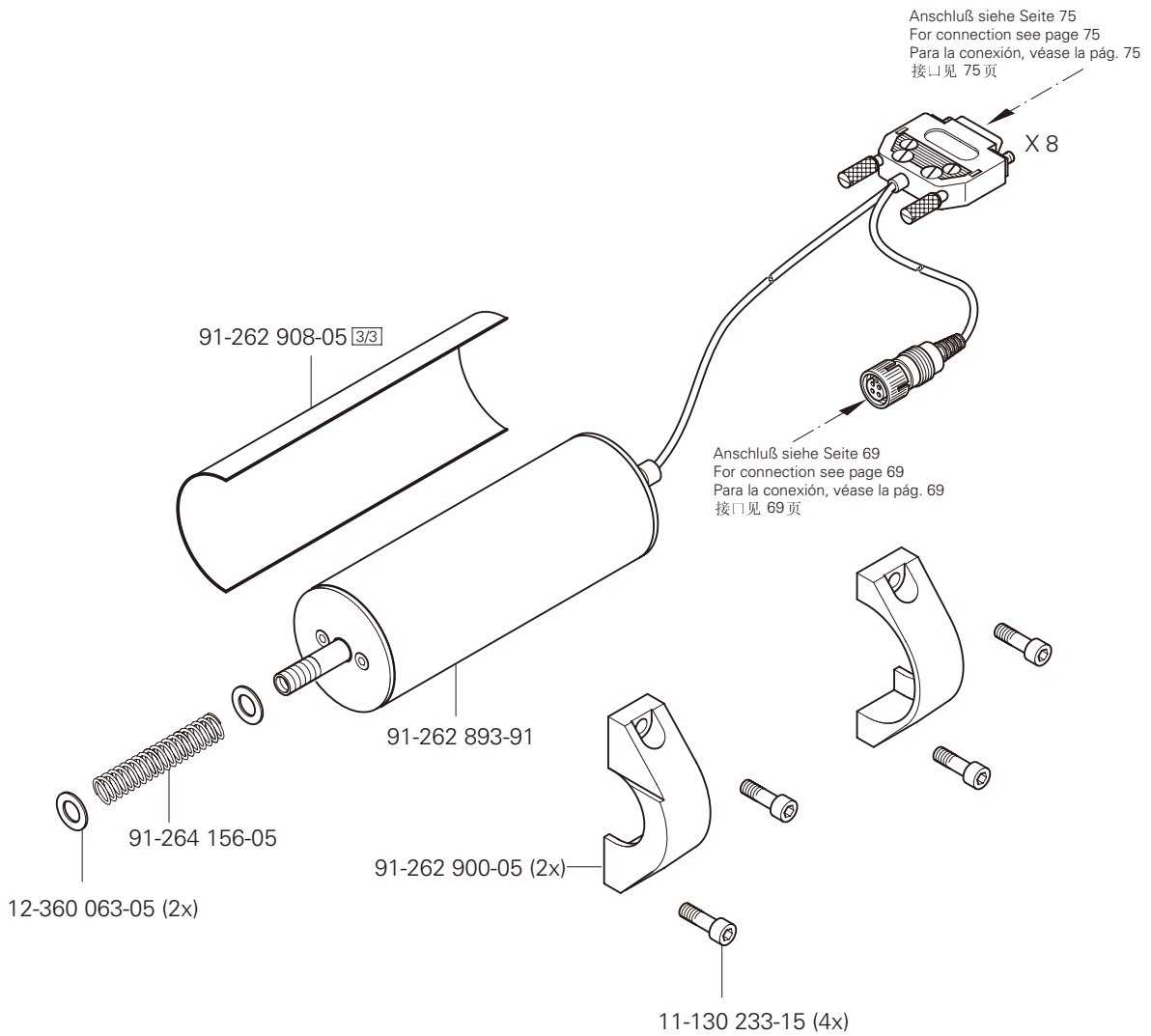

siehe Kapitel 2 Erläuterung der Schlüsselzeichen
see chapter 2 Explanation of key markings
véase el Cap. 2 Explicaciones de los signos clave
见第2章标记说明

(die sonstigen Teile wie in Register 3.01 bis 3.04)
(for all other parts see Sections 3.01 to 3.04)
(las demás piezas como en los registros 3.01 al 3.04)
(其它零件与3.01至3.04章中的相同)

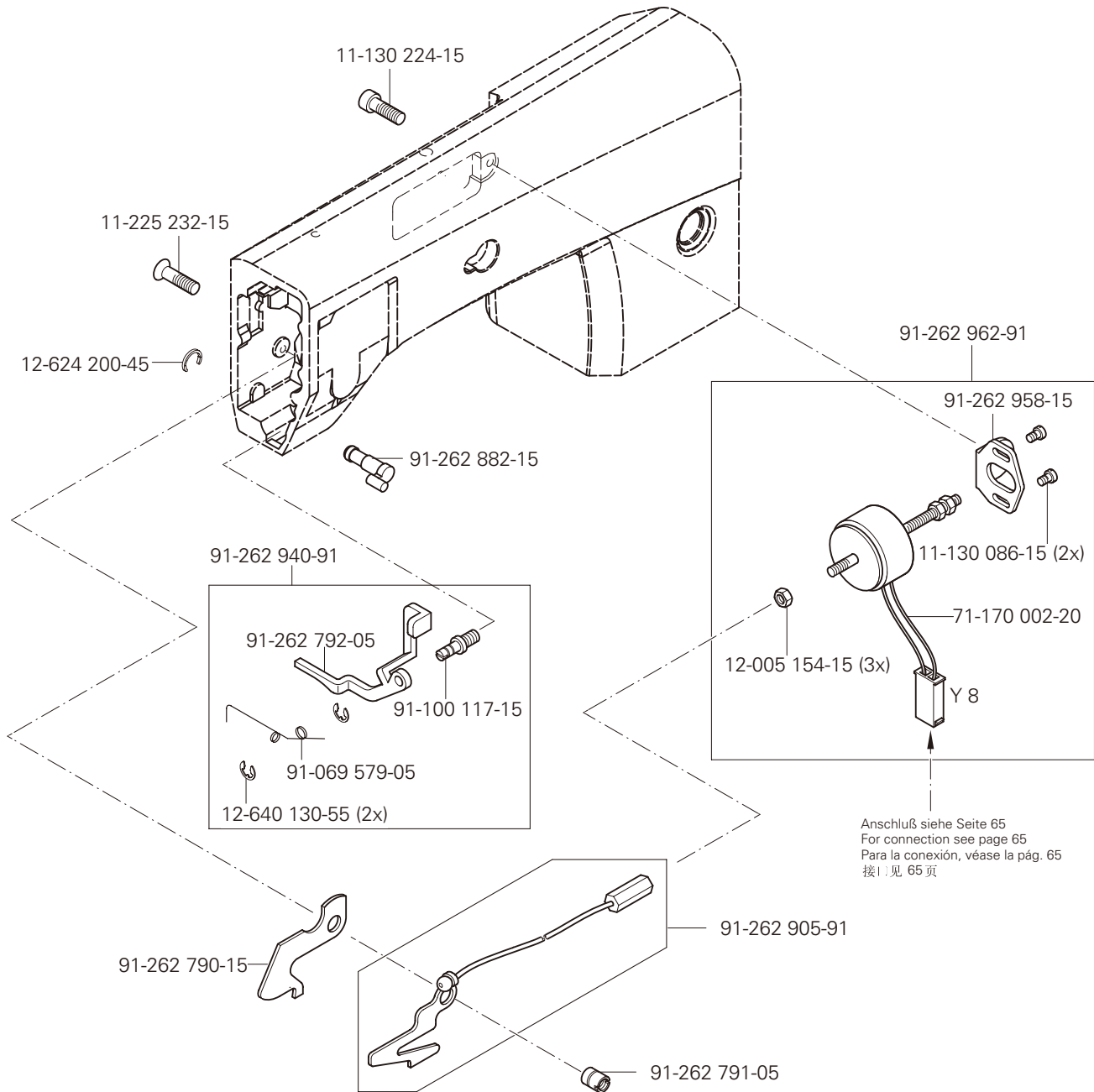
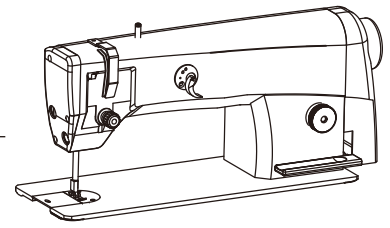

Anschluß siehe Seite 65
For connection see page 65
Para la conexión, véase la pág. 65
接线 见 65 页



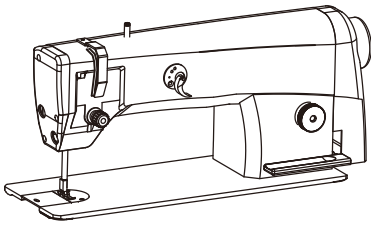

Kanten-Beschneideinrichtung (-731/01)
 Edge trimmer (-731/01)
 Recortador (-731/01) MA 2081
 切边器 (-731/01) MA 2083

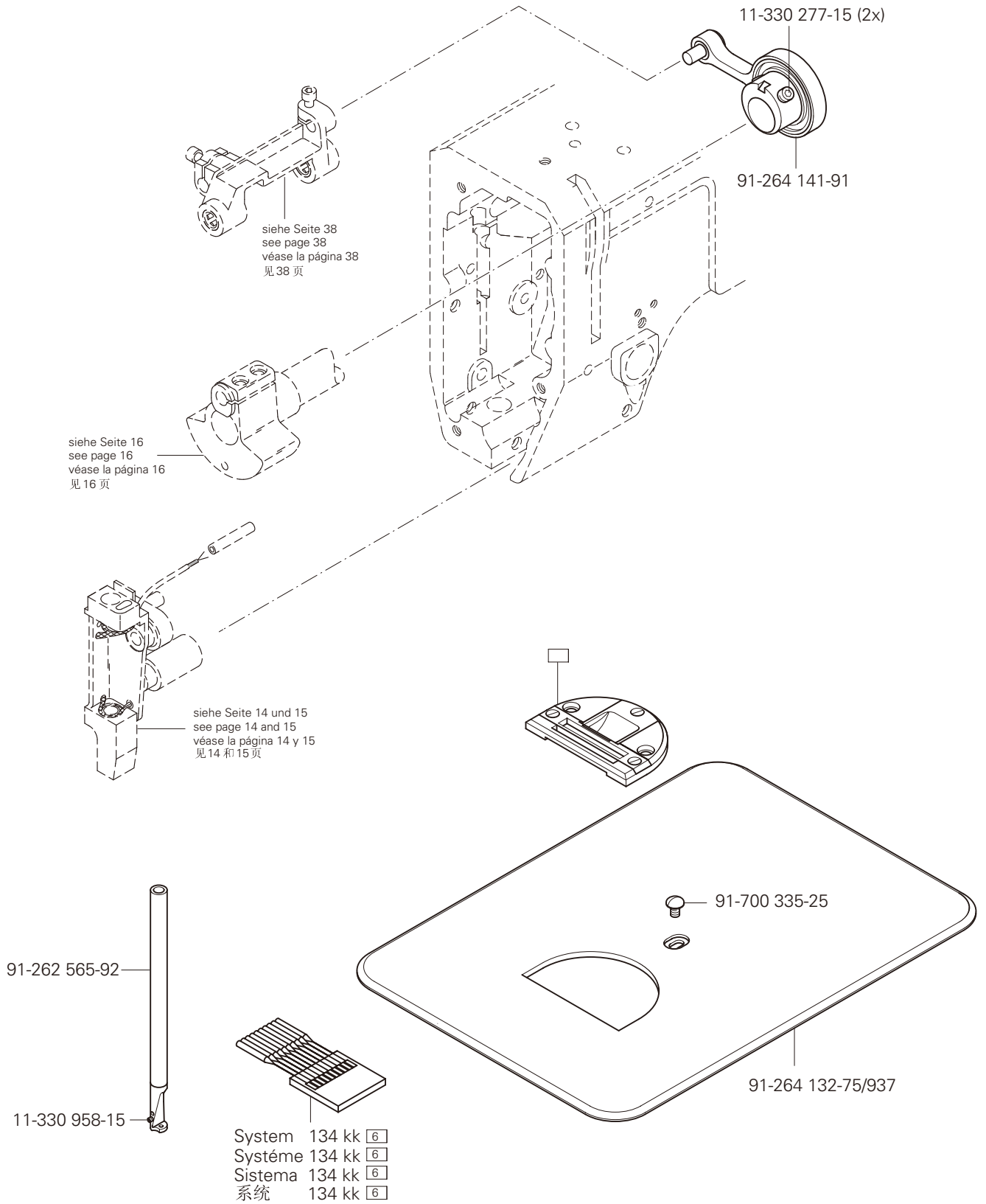

□ siehe Kapitel 2 Erläuterung der Schlüsselzeichen
 see chapter 2 Explanation of key markings
 véase el Cap. 2 Explicaciones de los signos clave
 见第2章标记说明

(die sonstigen Teile wie in Register 3.01 bis 3.04)
 (for all other parts see Sections 3.01 to 3.04)
 (las demás piezas como en los registros 3.01 al 3.04)
 (其它零件与3.01至3.04章中的相同)

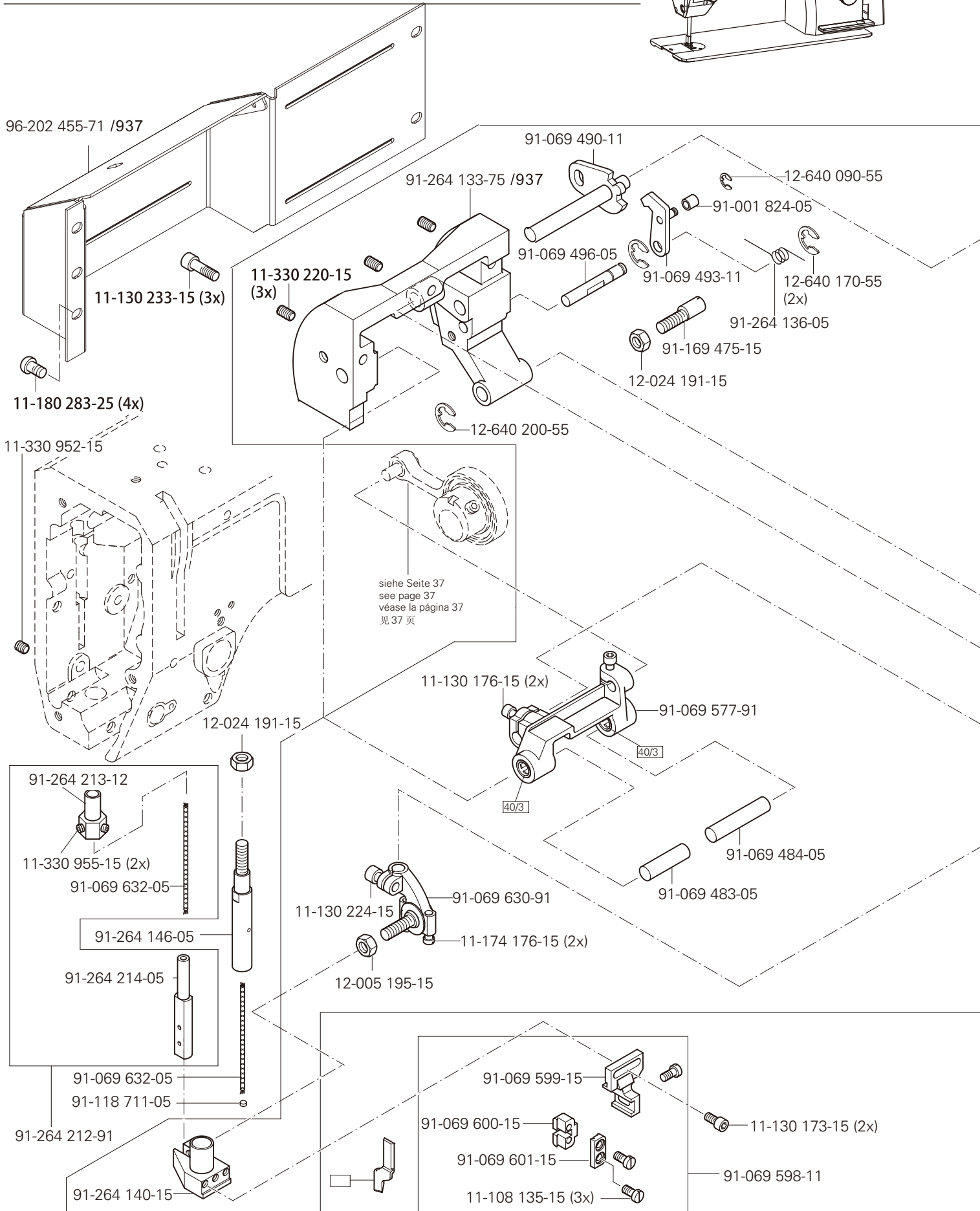
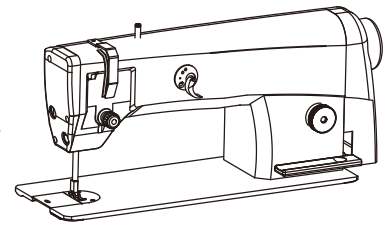

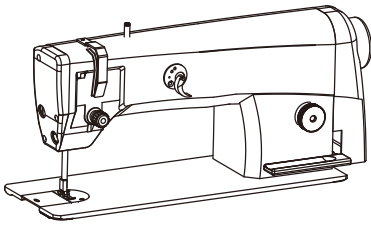

Kanten-Beschneideinrichtung (-731/01)
 Edge trimmer (-731/01)
 Recortador (-731/01) MA 2081
 切边器 (-731/01) MA 2083

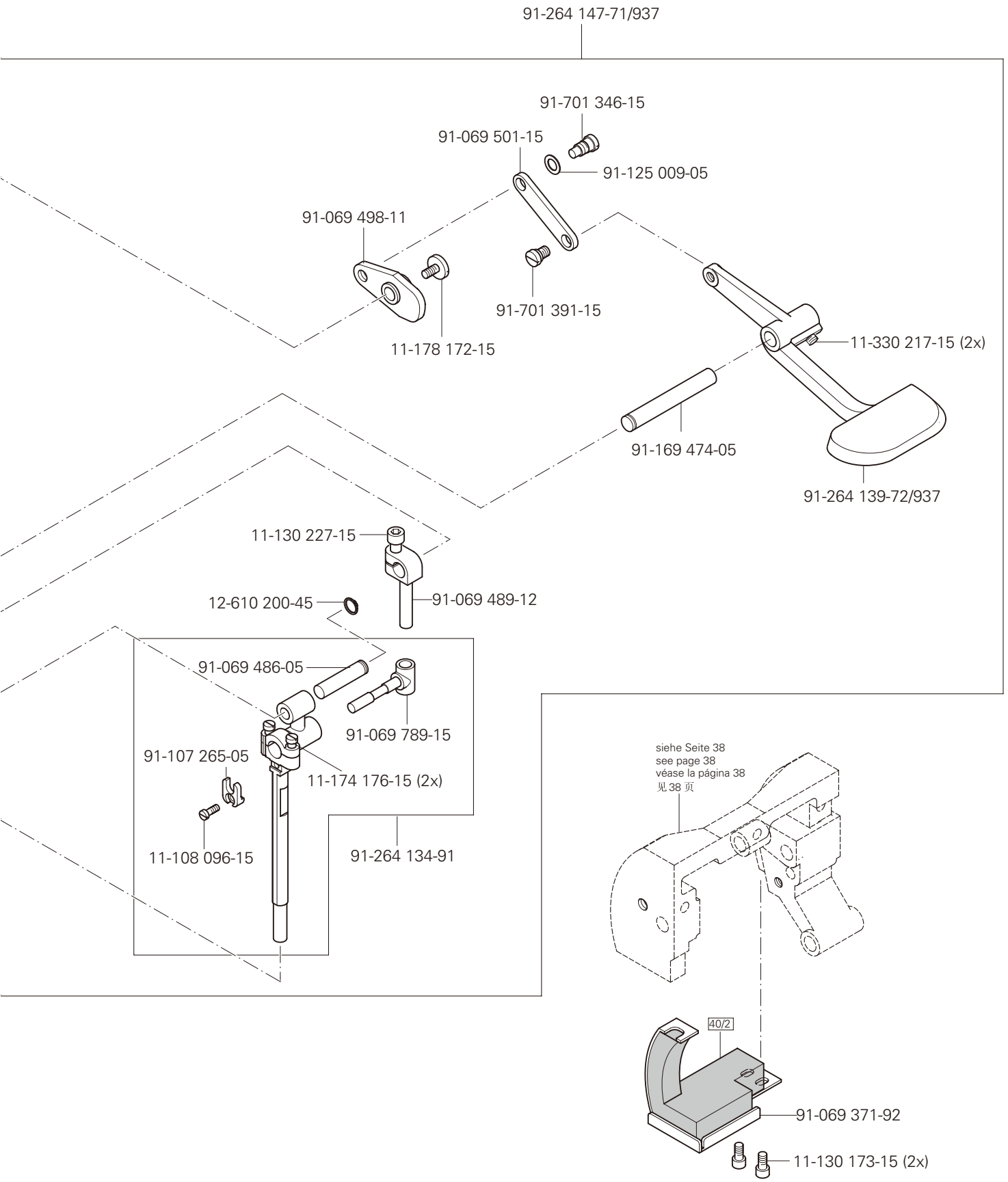

☐ siehe Kapitel 2 Erläuterung der Schlüsselzeichen
 see chapter 2 Explanation of key markings
 véase el Cap. 2 Explicaciones de los signos clave
 见第2章标记说明

(die sonstigen Teile wie in Register 3.01 bis 3.04)
 (for all other parts see Sections 3.01 to 3.04)
 (las demás piezas como en los registros 3.01 al 3.04)
 (其它零件与3.01 至3.04 章中的相同)

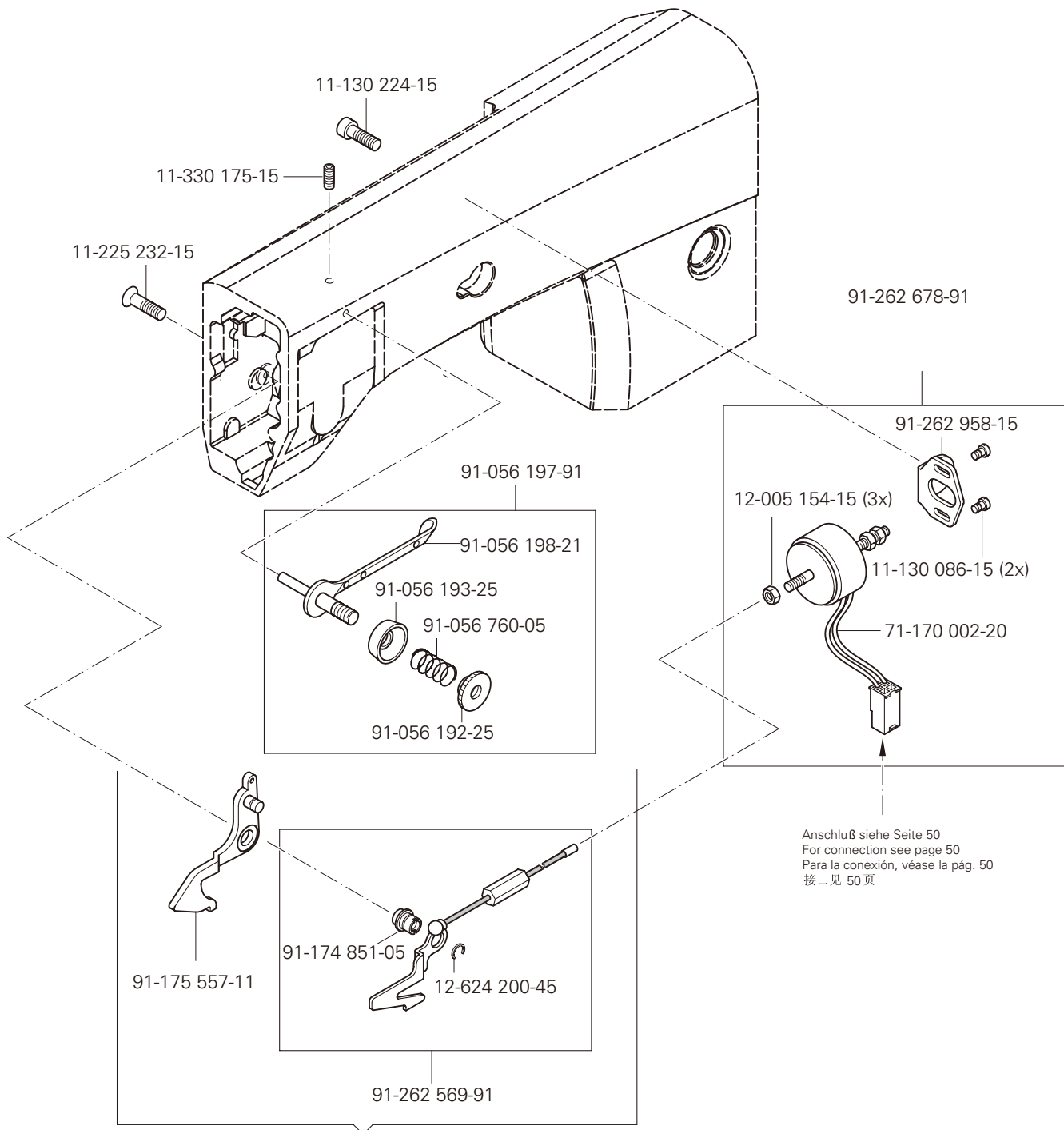
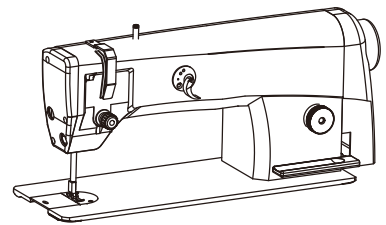

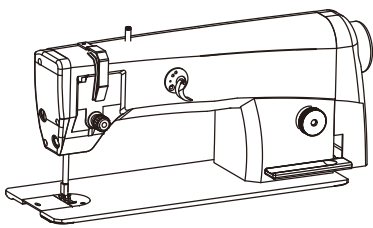

Fadenabschneid-Einrichtung (-900/24)

Thread trimmer (-900/24)

Cortahilos (-900/24)

切线器 (-900/24)

MA 2081;2081-D;2081-G

MA 2083;2083-D;2083-G

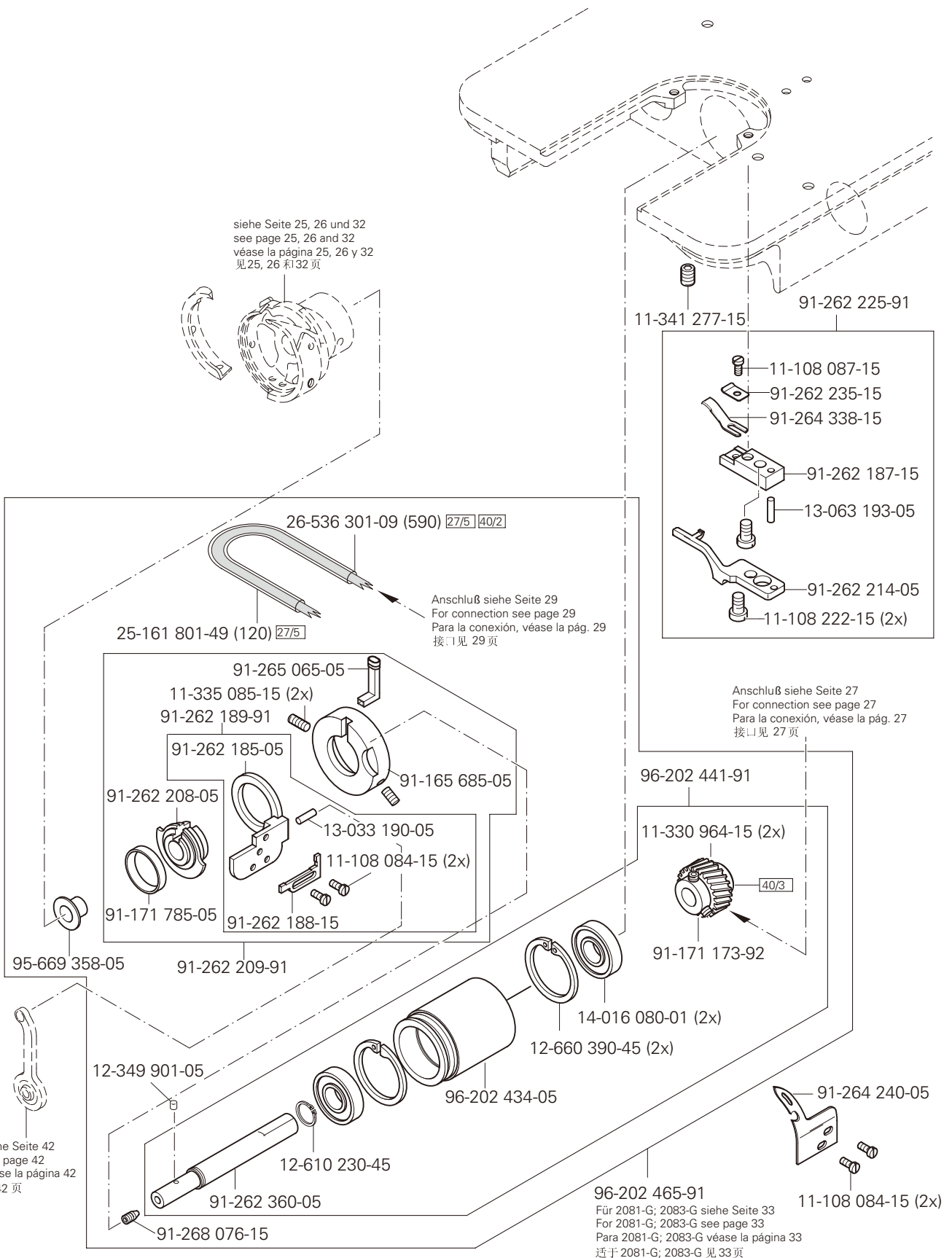

siehe Seite 42
see page 42
véase la página 42
见 42 页

 siehe Kapitel 2 Erläuterung der Schlüsselzeichen
see chapter 2 Explanation of key markings
véase el Cap. 2 Explicaciones de los signos clave
见第2章标记说明

(die sonstigen Teile wie in Register 3.01 bis 3.04)
(for all other parts see Sections 3.01 to 3.04)
(las demás piezas como en los registros 3.01 al 3.04)
(其它零件与3.01至3.04章中的相同)

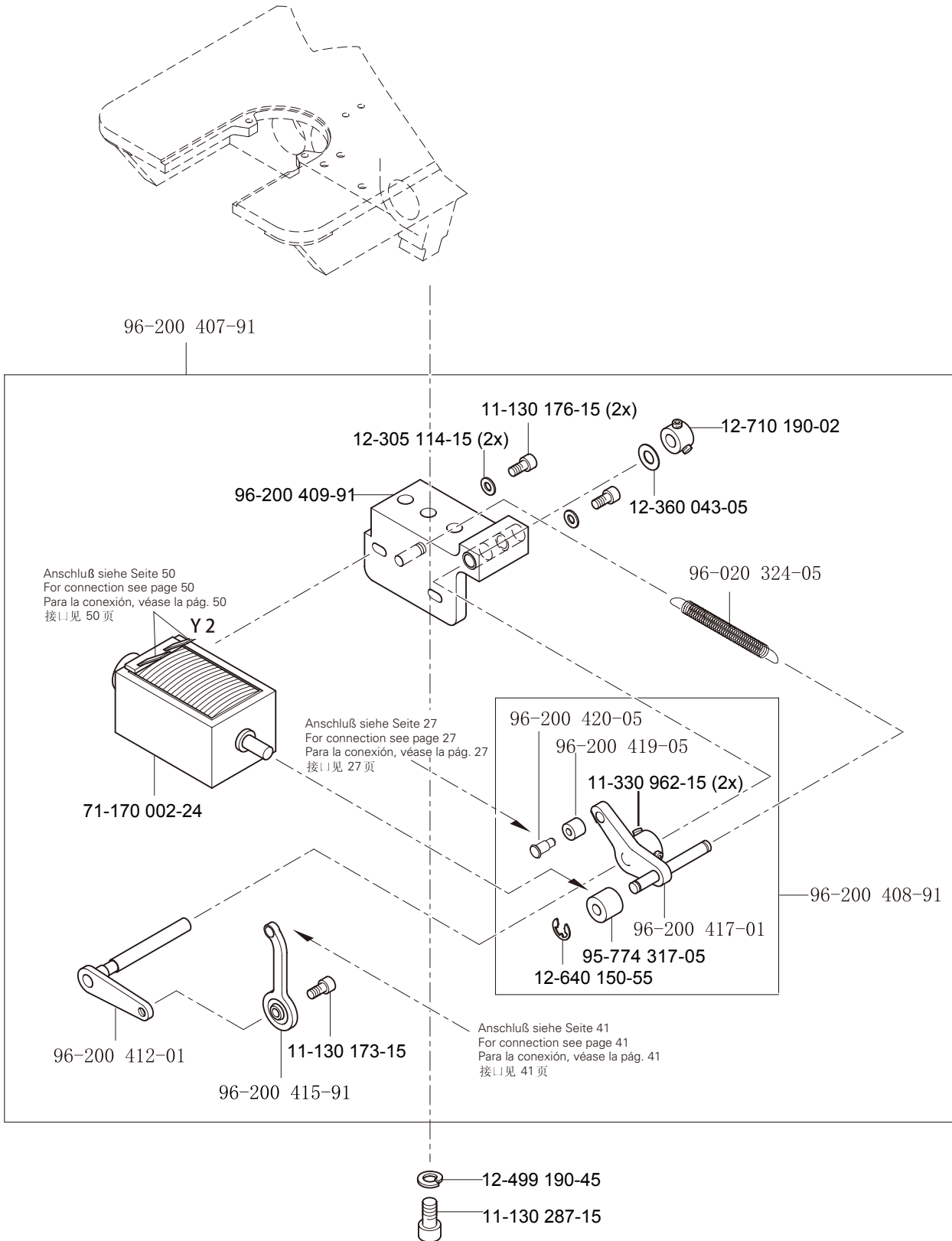
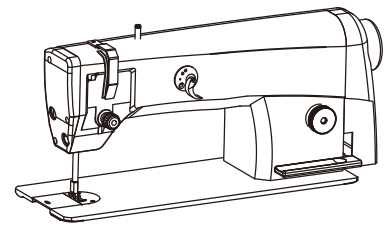

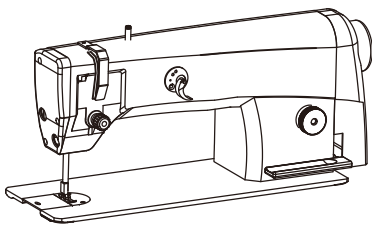

Fadenklemme (-909/14)
 Thread trapper (-909/14)
 Pinza sujetahilos (-909/14)
 夹线器 (-909/14)

MA 2081;2081-D;2081-G
 MA 2083;2083-D;2083-G

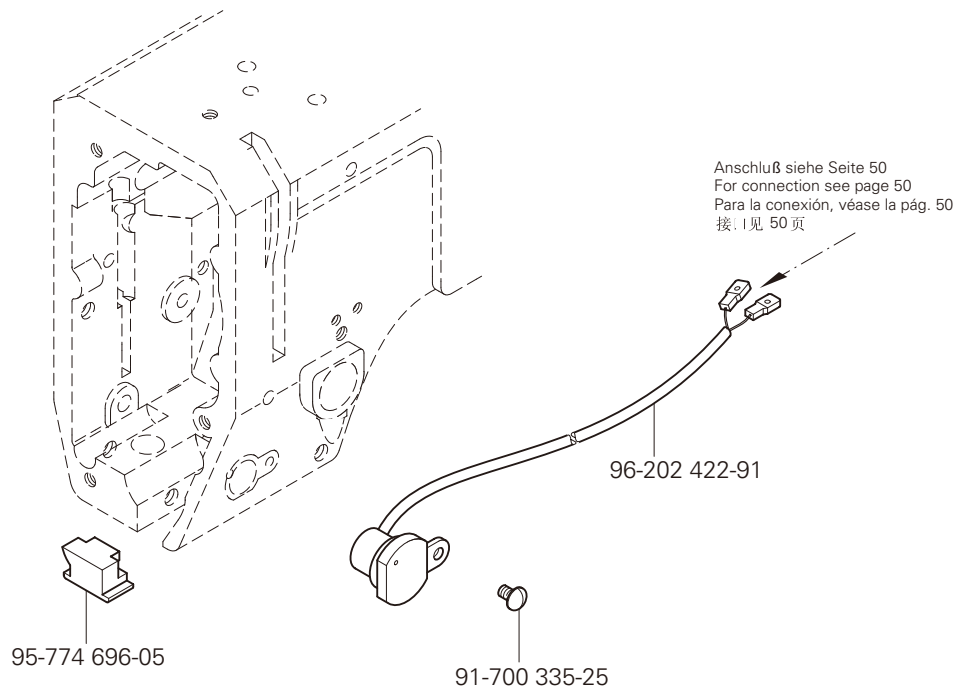

Presserfuß-Automatik (-910/06)

Automatic presser foot lifter (-910/06) MA 2081-900/24;2081- D-900/24;2081-G-900/24

Alzaprensatelas (-910/06) MA 2083-900/24;2083- D-900/24;2083-G-900/24

压脚自动提升器 (-910/06) MA 2081-731/01-900/24;2083-731/01-900/2 4

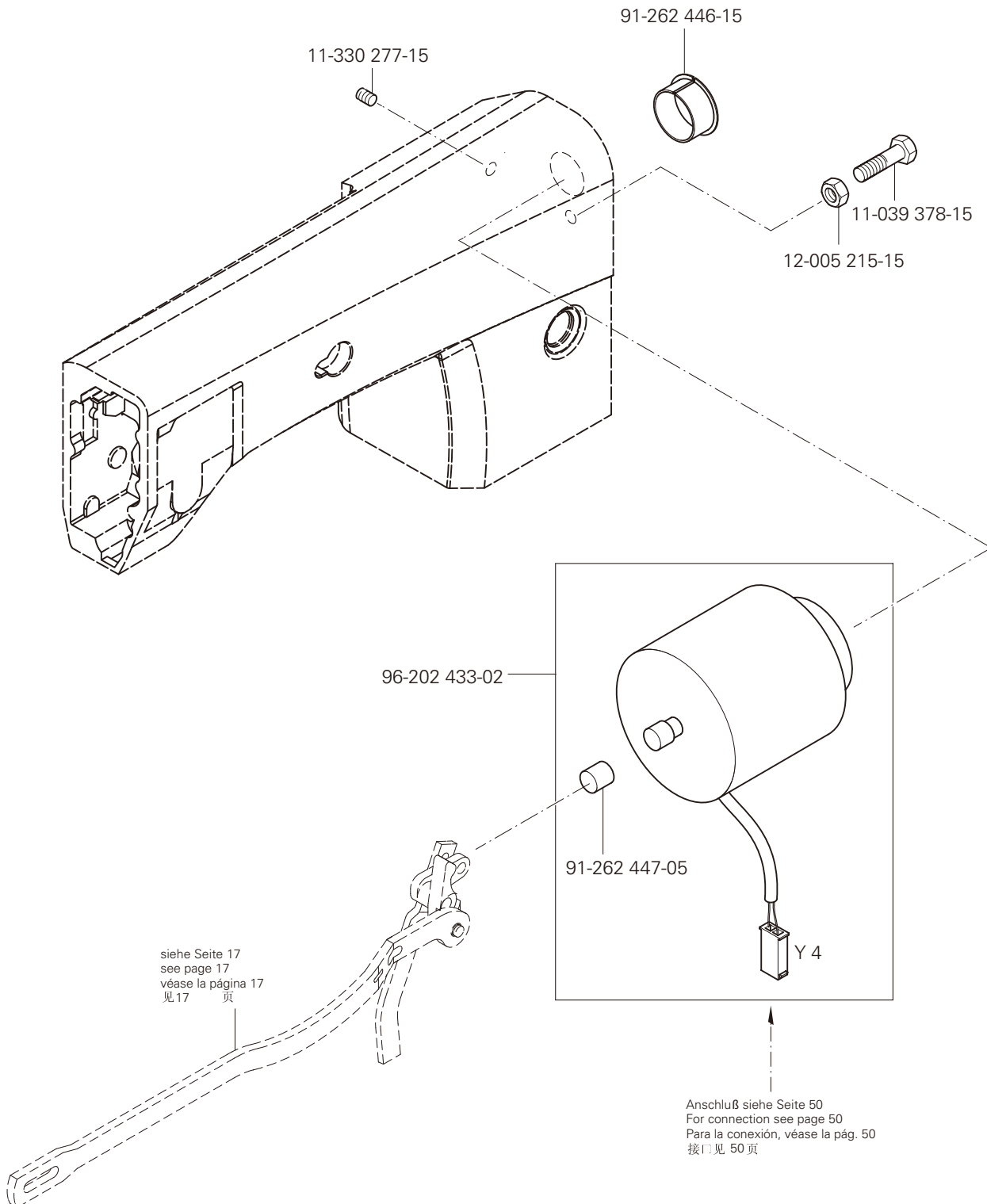
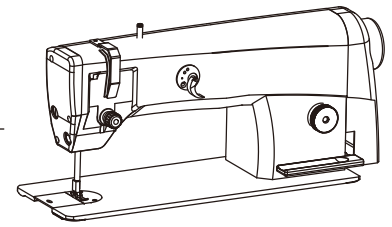

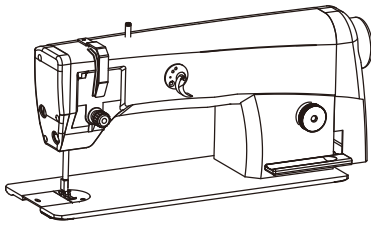

Verriegelungs-Einrichtung (-911/37)
 Backtacking mechanism (-911/37)
 Rematador (-911/37)
 锁紧装置 (-911/37)

MA 2081-900/24;2081-D-900/24;2081- G-900/24
 MA 2083-900/24;2083-D-900/24;2083- G-900/24
 MA 2081-731/01-900/24;2083-731/01-900/24

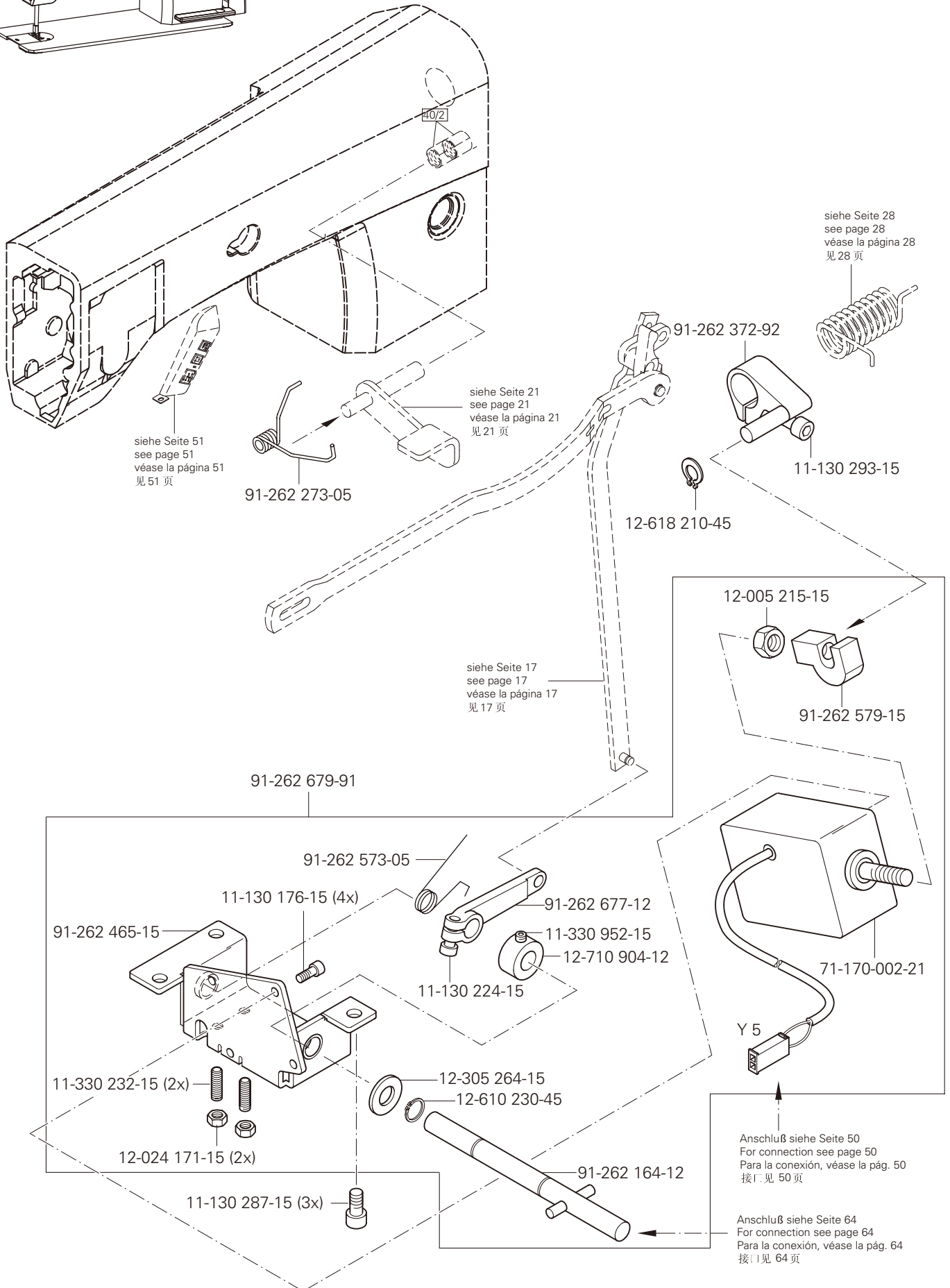

siehe Kapitel 2 Erläuterung der Schlüsselzeichen
 see chapter 2 Explanation of key markings
 véase el Cap. 2 Explicaciones de los signos clave
 见第2章标记说明

(die sonstigen Teile wie in Register 3.01 bis 3.04)
 (for all other parts see Sections 3.01 to 3.04)
 (las demás piezas como en los registros 3.01 al 3.04)
 (其它零件与3.01至3.04章中的相同)

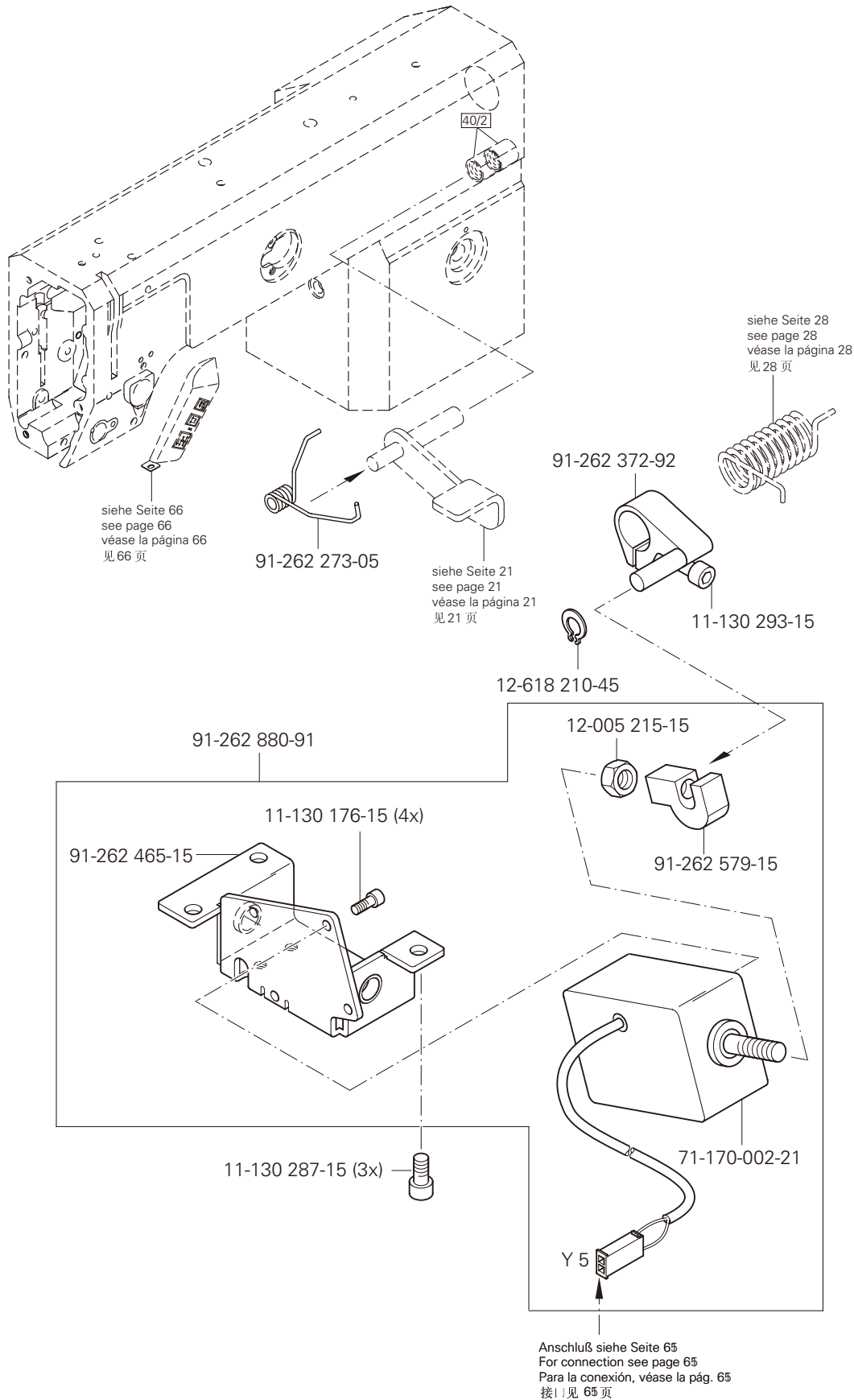
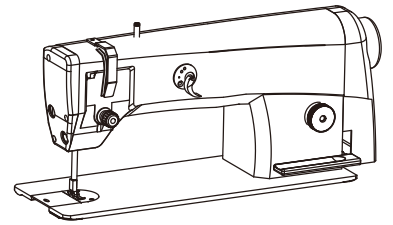

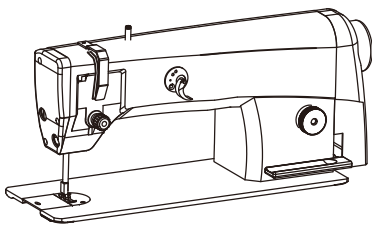

Spulensfadenvorratswächter (-926/06)

Bobbin thread supply monitor (-926/06) MA 2081; 2083

Detector del hilo de la canilla (-926/06) MA 2081-731/01;2083-731/01

底线余量监视器 (-926/06)

MA 2081-948/26; 2083-948/26

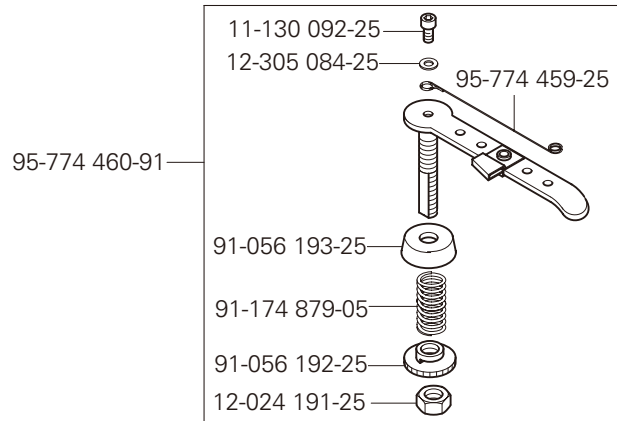

95-774 525-91 (MA 2081)

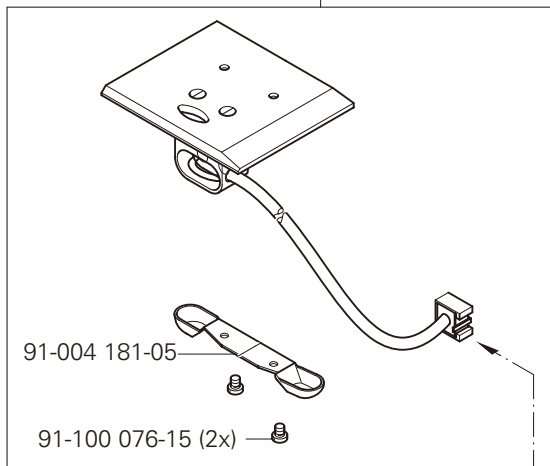

Anschluß siehe Seite 57 und 61
For connection see page 57 and 61
Para la conexión, véase la pág. 57 y 61
接口见 57和 61 页

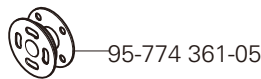

95-774 524-91 (MA 2083)

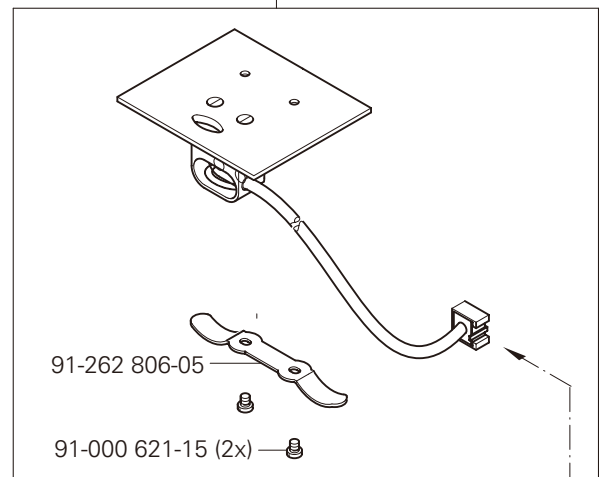

Anschluß siehe Seite 57 und 61
For connection see page 57 and 61
Para la conexión, véase la pág. 57 y 61
接口见 57和 61 页

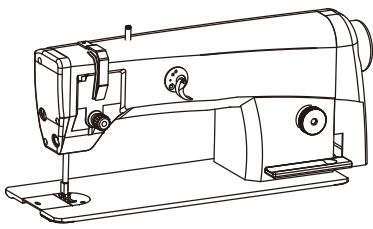

Walzentransport-Einrichtung (-948/26)

Puller feed (-948/26)

Puller (-948/26)

滚筒送料器 (-948/26)

MA 2081-900/24

MA 2083-900/24

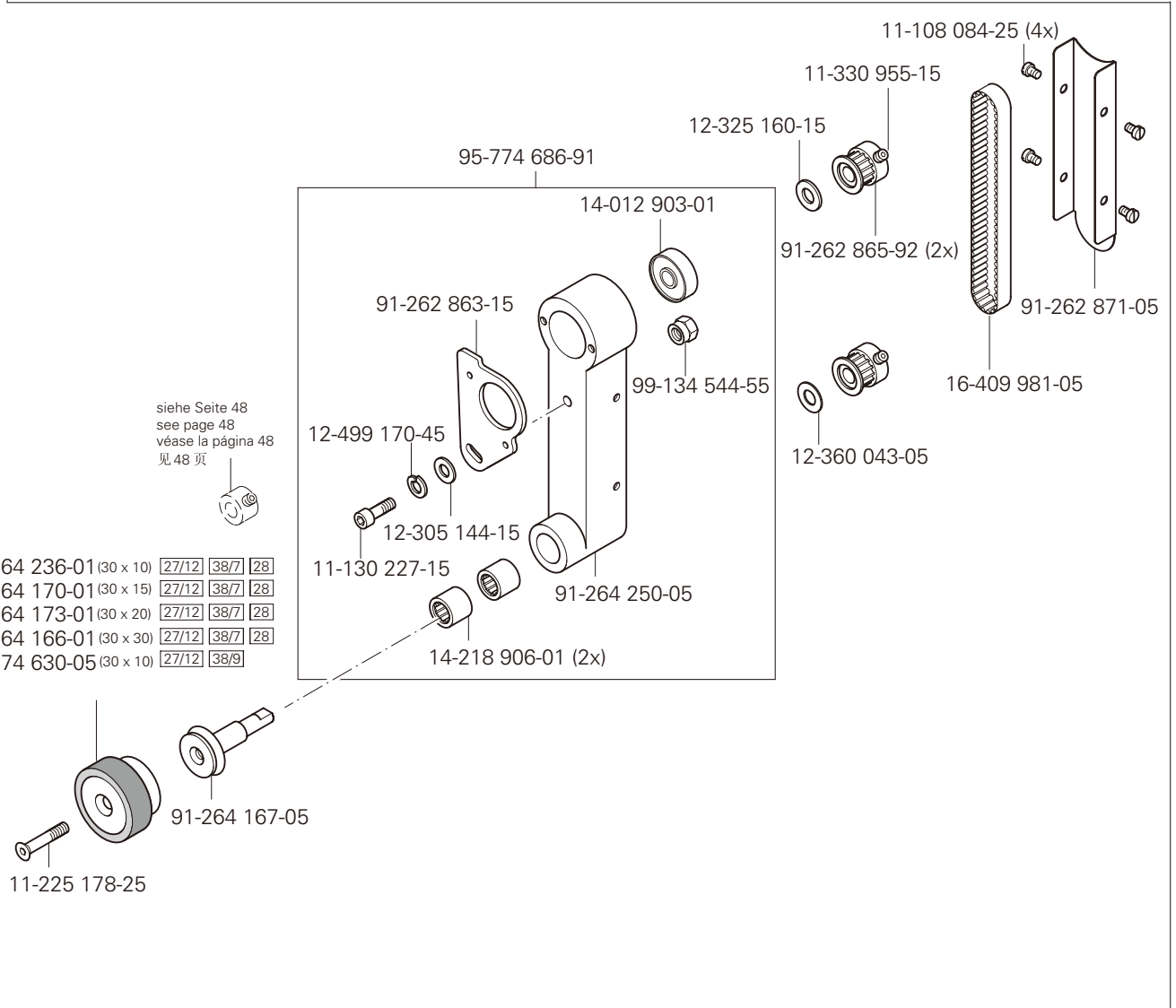
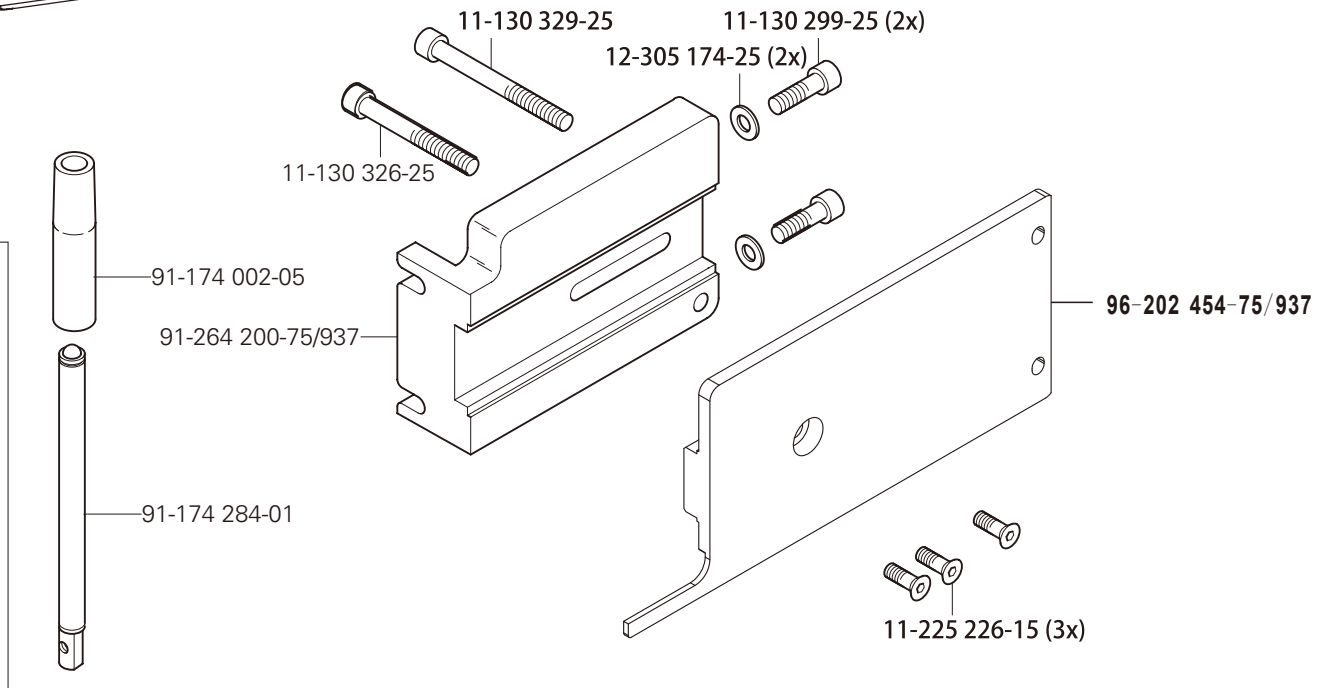

siehe Seite 48
see page 48
véase la página 48
见 48 页

- 91-264 236-01 (30 x 10) 27/12 38/7 28
- 91-264 170-01 (30 x 15) 27/12 38/7 28
- 91-264 173-01 (30 x 20) 27/12 38/7 28
- 91-264 166-01 (30 x 30) 27/12 38/7 28
- 95-774 630-05 (30 x 10) 27/12 38/9

Kabelbaum zum Oberteil

Cable tree to sewing head

Mazo de cables para el cabezal MA 2081-900/24;2081-D-900/24;2081-G-900/24

上部机器电缆束

MA 2083-900/24;2083-D-900/24;2083-G-900/24

13.01

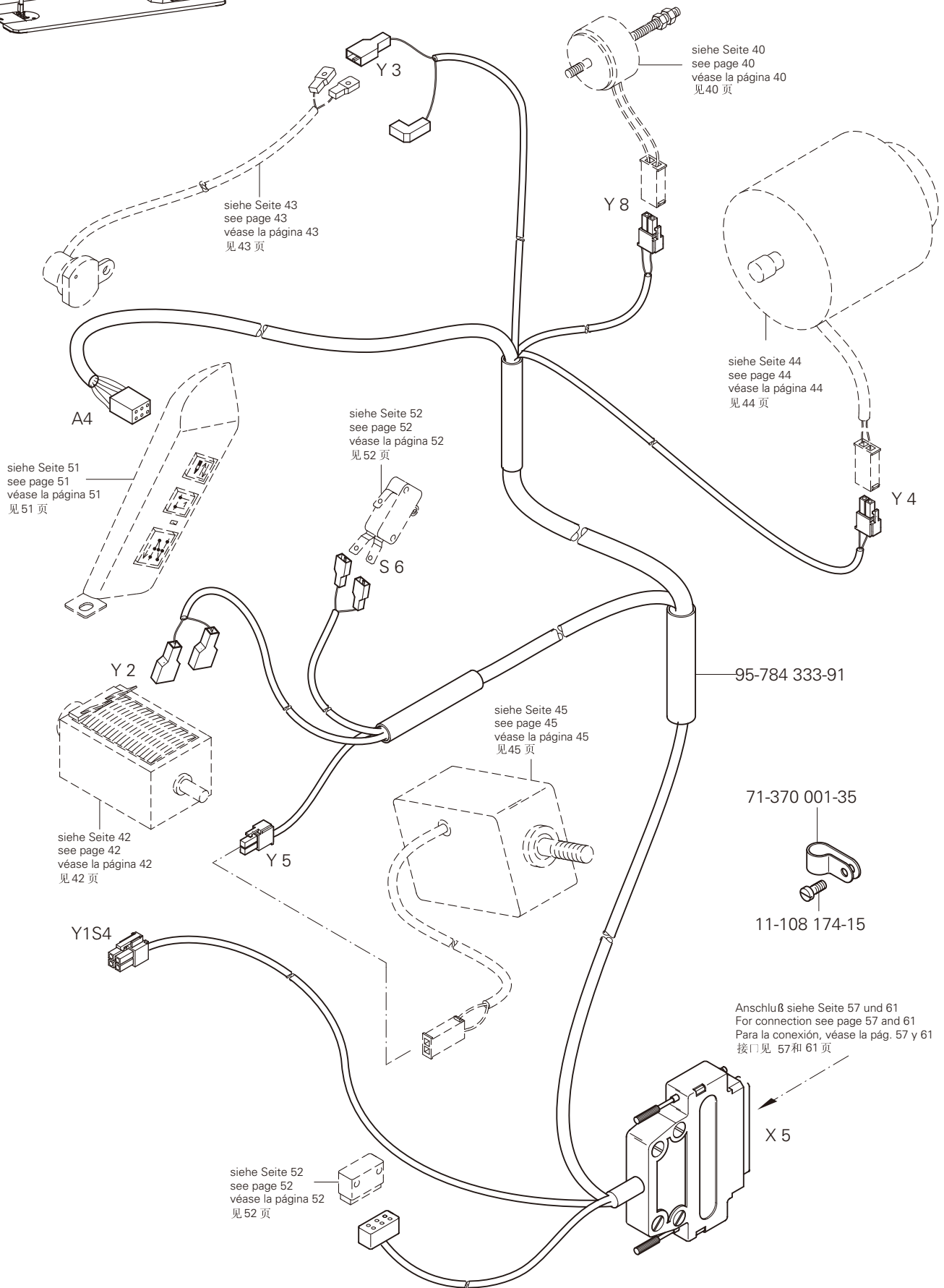
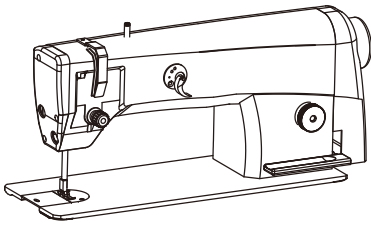

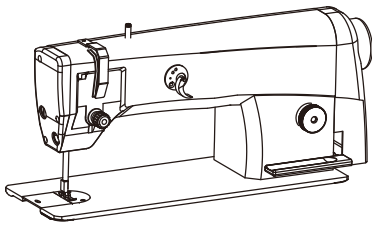

Tastschalter
Push-button
Interruptor pulsador
按钮开关

MA 2081-911/37;2081-D-911/37
MA 2083-911/37;2083-D-911/37

13.02

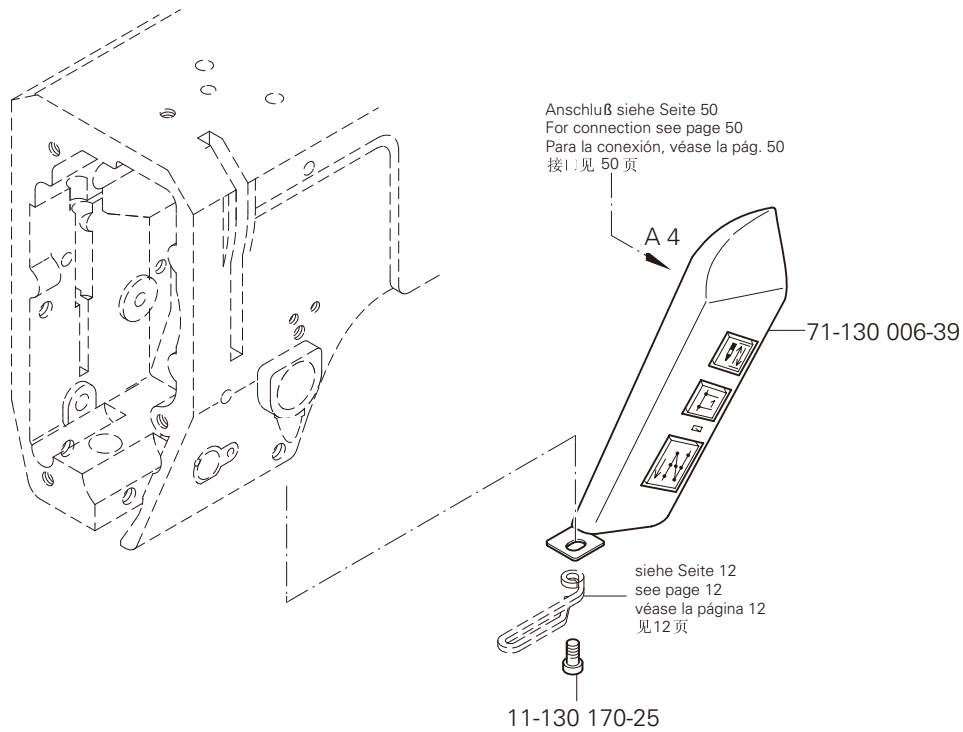

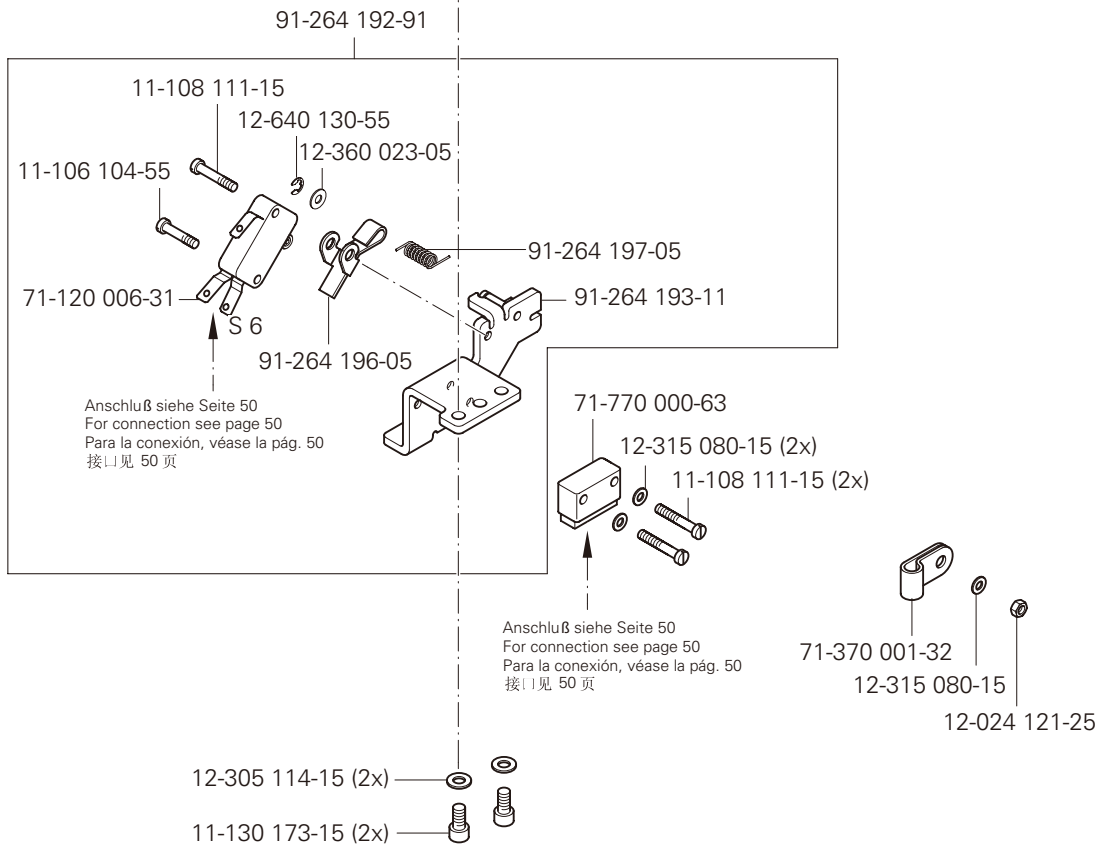
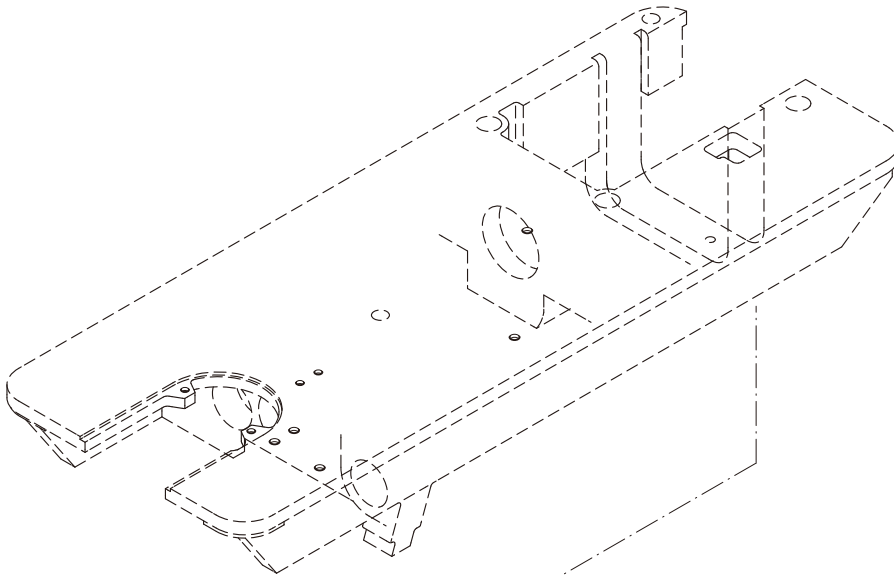
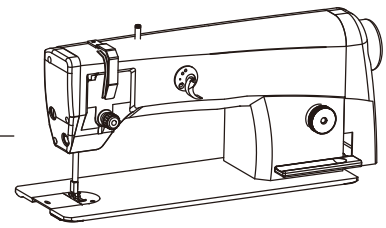

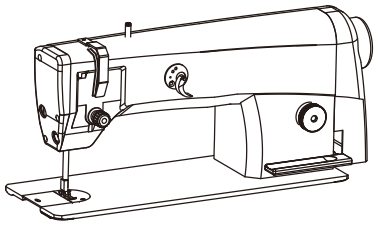

Einbaumotor
Built-in motor
Motor incorporado
内装式电机

MA 2081-900/24
MA 2083-900/24

13.04

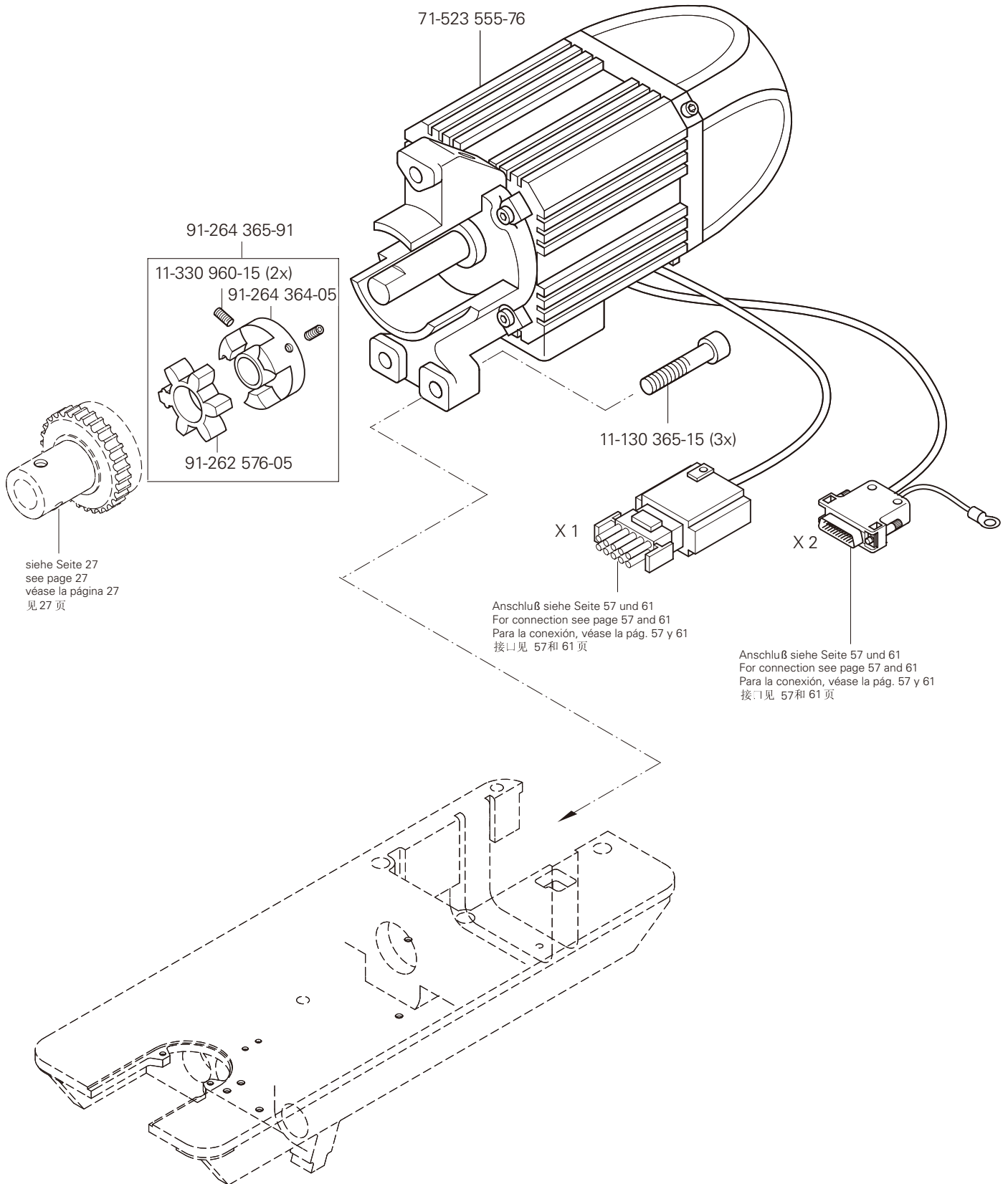

siehe Kapitel 2 Erläuterung der Schlüsselzeichen
see chapter 2 Explanation of key markings
véase el Cap. 2 Explicaciones de los signos clave
见第2章标记说明

13.05

Motor-Hauptschalter
Main switch
Interruptor principal
电机主开关

MA 2081
MA 2083

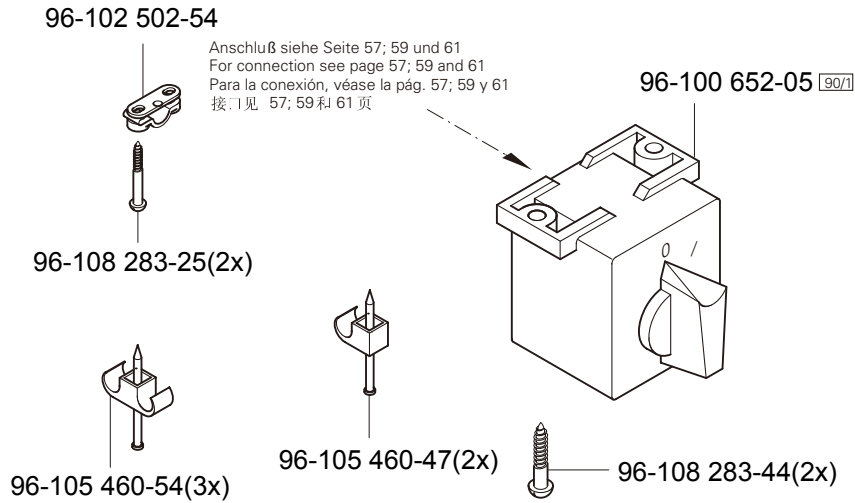
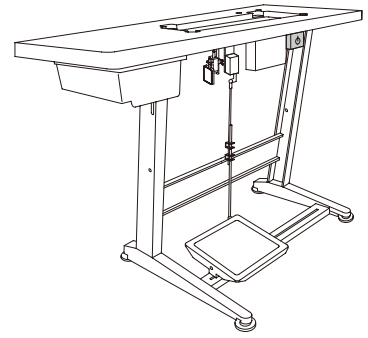

13.06

Knietaster mit Leitung
Knee switch with cable
Interruptor de rodillera con cable
带电缆膝键

MA 2081 SRP-900/24
MA 2083 SRP-900/24

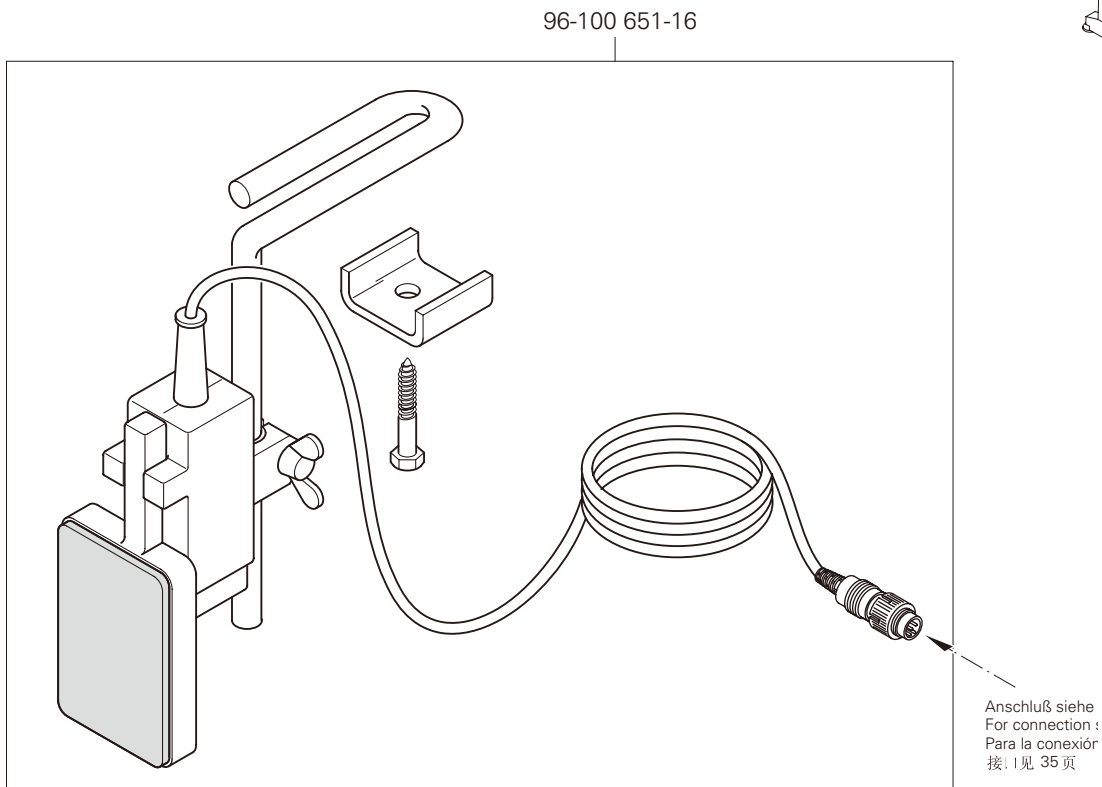
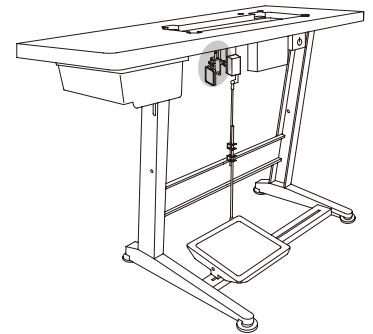

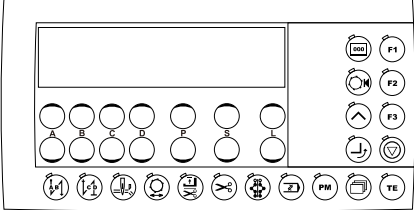
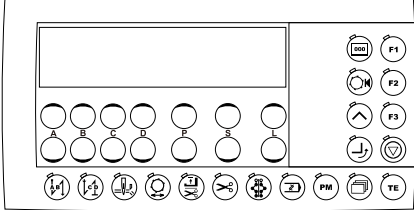
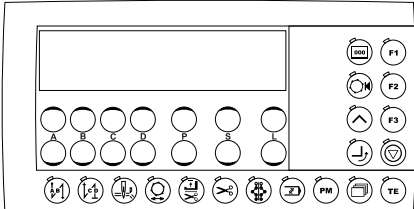
<p>Klasse Class Clase 机型</p>	<p>Steuerungspaket Control package Paquete de control 控制组件</p>	<p>Abbildung siehe Seite: Stitching margin Margen de costura 图见页号</p>
<p>MA 2081; MA 2083 MAUSER-BDF S3</p> 	<p>Mauser Drive mit MA 40ED-A Best.-Nr. Part number N° de pedido 订货号</p> <p>71-590 007-84</p>	<p>56; 57</p>
<p>MA 2081-SRP; MA 2083-SRP MAUSER-BDF S3</p> 	<p>Mauser Drive mit MA 50ED Best.-Nr. Part number N° de pedido 订货号</p> <p>71-590 007-89</p>	<p>58; 59</p>
<p>MA 2081-948/26 ; MA 2083-948/26; MAUSER-BDF S3</p> 	<p>Mauser Drive mit MA 350ED Best.-Nr. Part number N° de pedido 订货号</p> <p>71-590 008-35</p>	<p>60; 61</p>

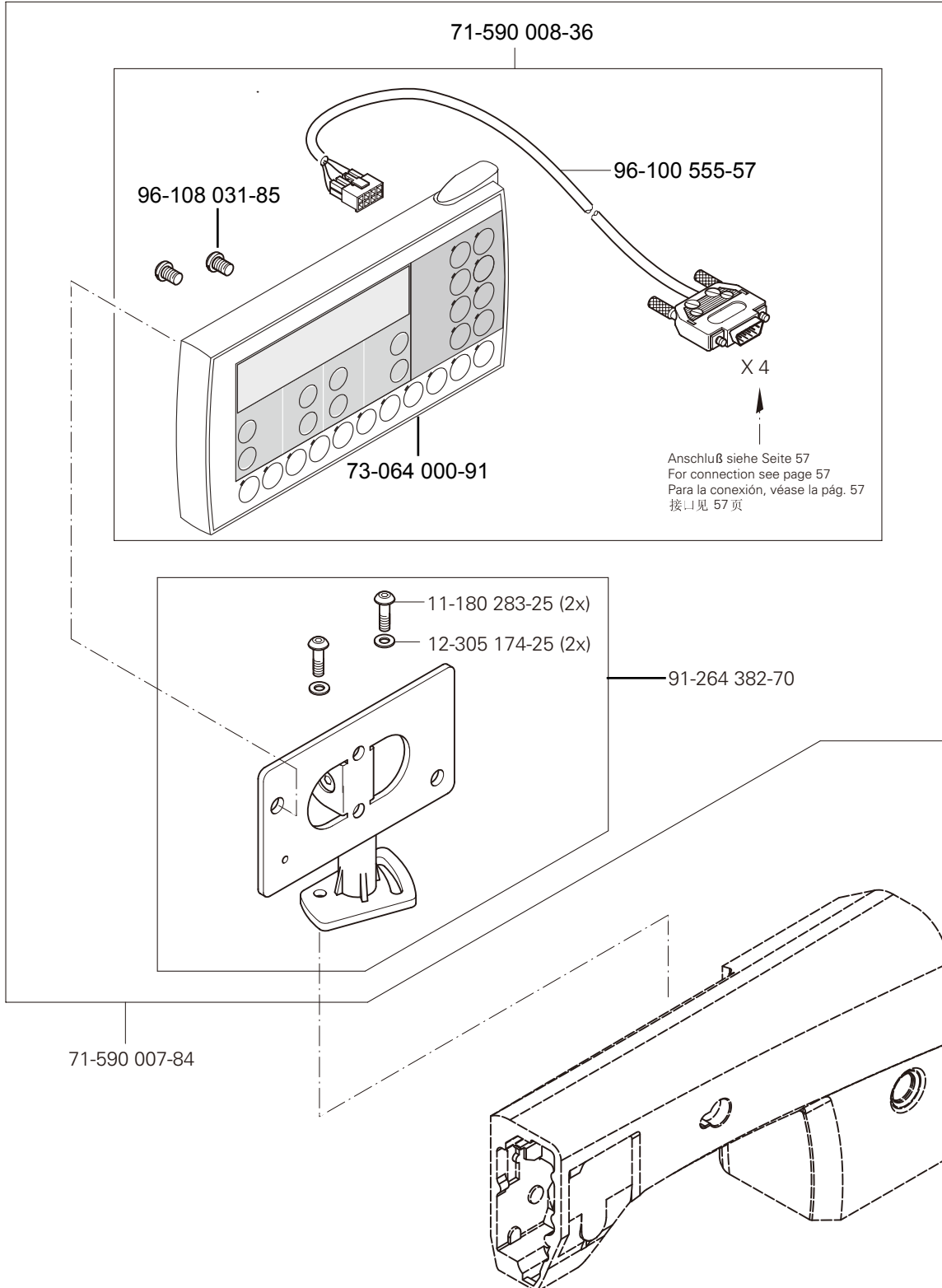
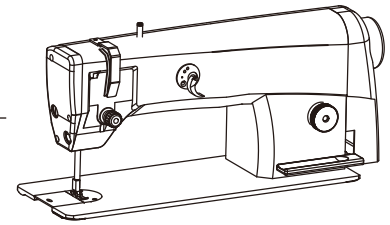

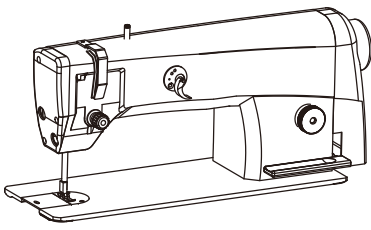

Steuerungspaket Mauser Drive mit MA 40 ED-A
 Control package Mauser Drive with MA 40 ED-A
 Paquete de control Mauser Drive con MA 40 ED-A
 控制组件 Mauser Drive 带 MA 40 ED-A

MA 2081
 MA 2083

13.08

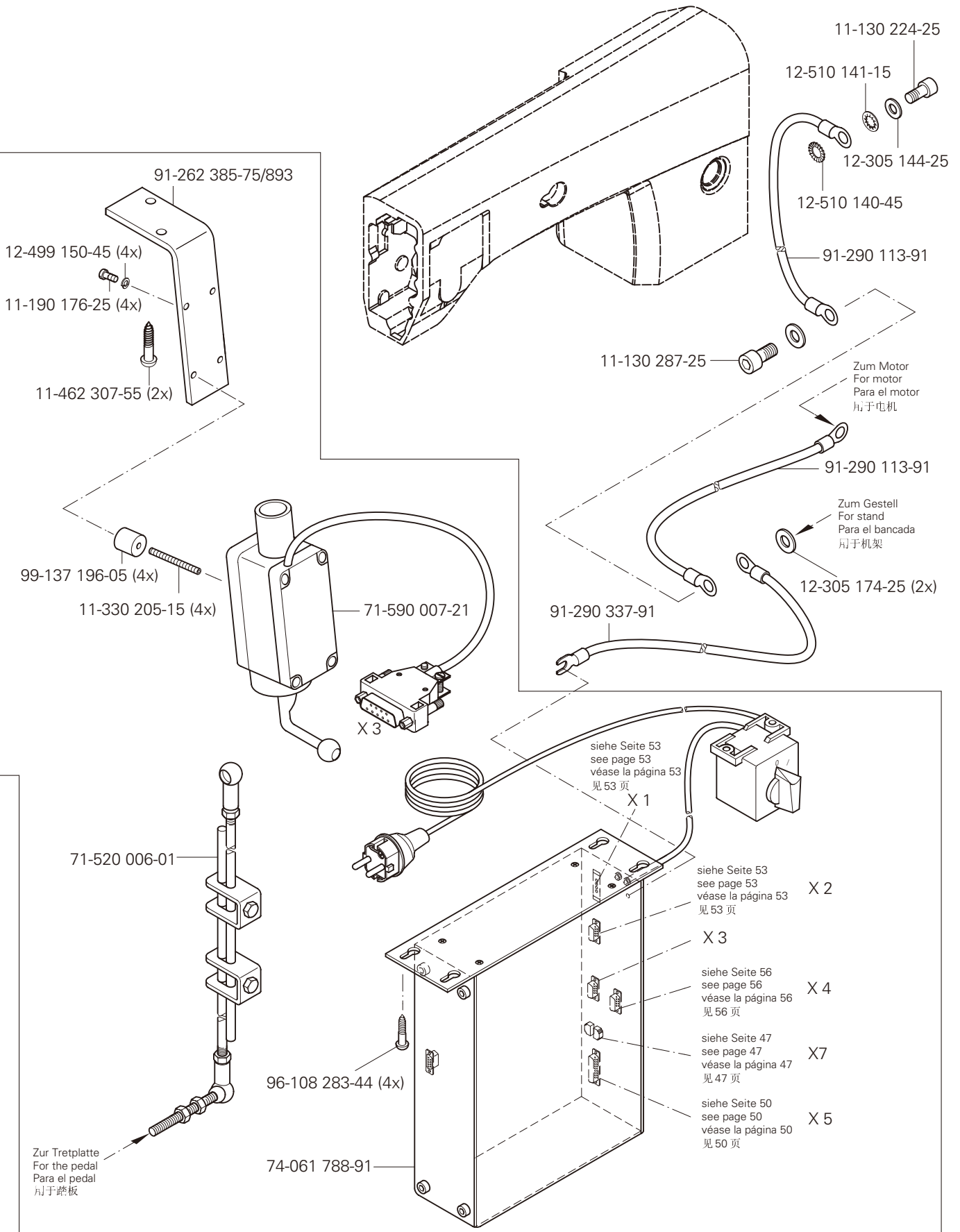

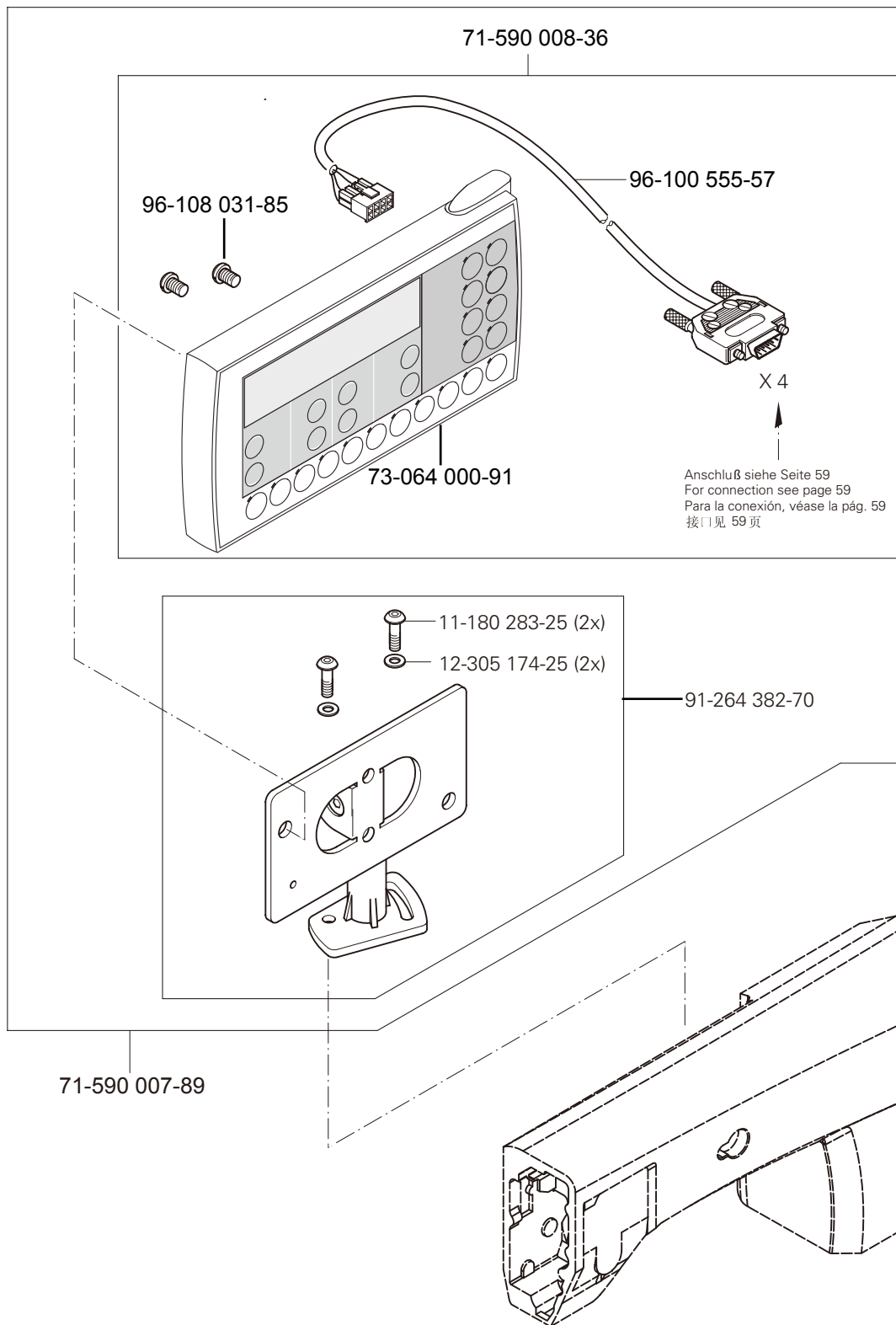
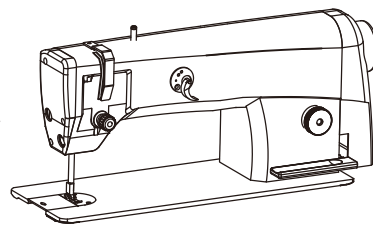

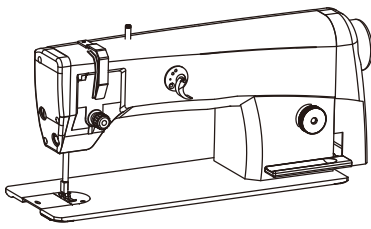

Steuerungspaket Mauser Drive mit MA 50 ED
 Control package Mauser Drive with MA 50 ED
 Paquete de control Mauser Drive con MA 50 ED MA 2081
 控制组件 Mauser Drive 带 MA 50 ED MA 2083

13.09

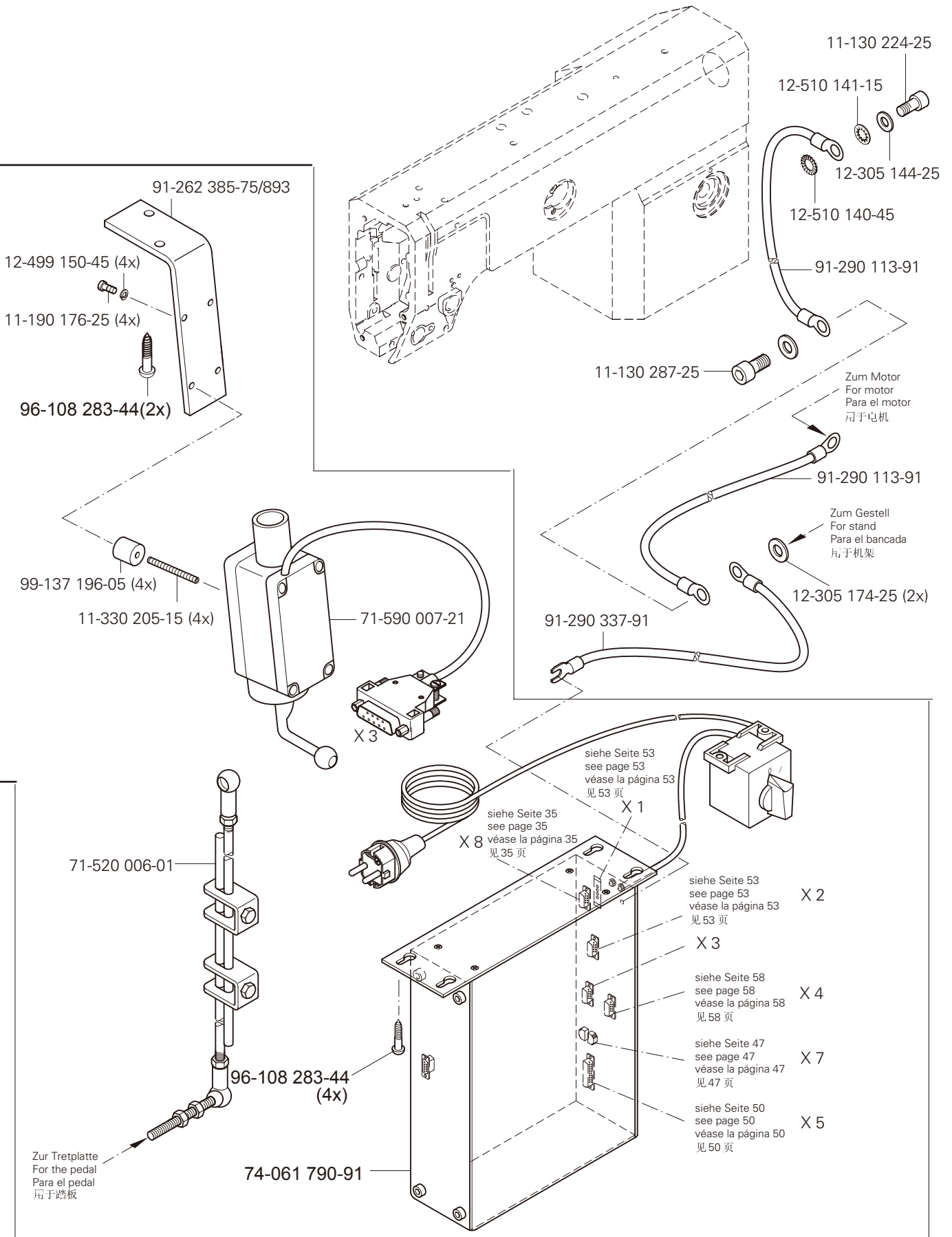

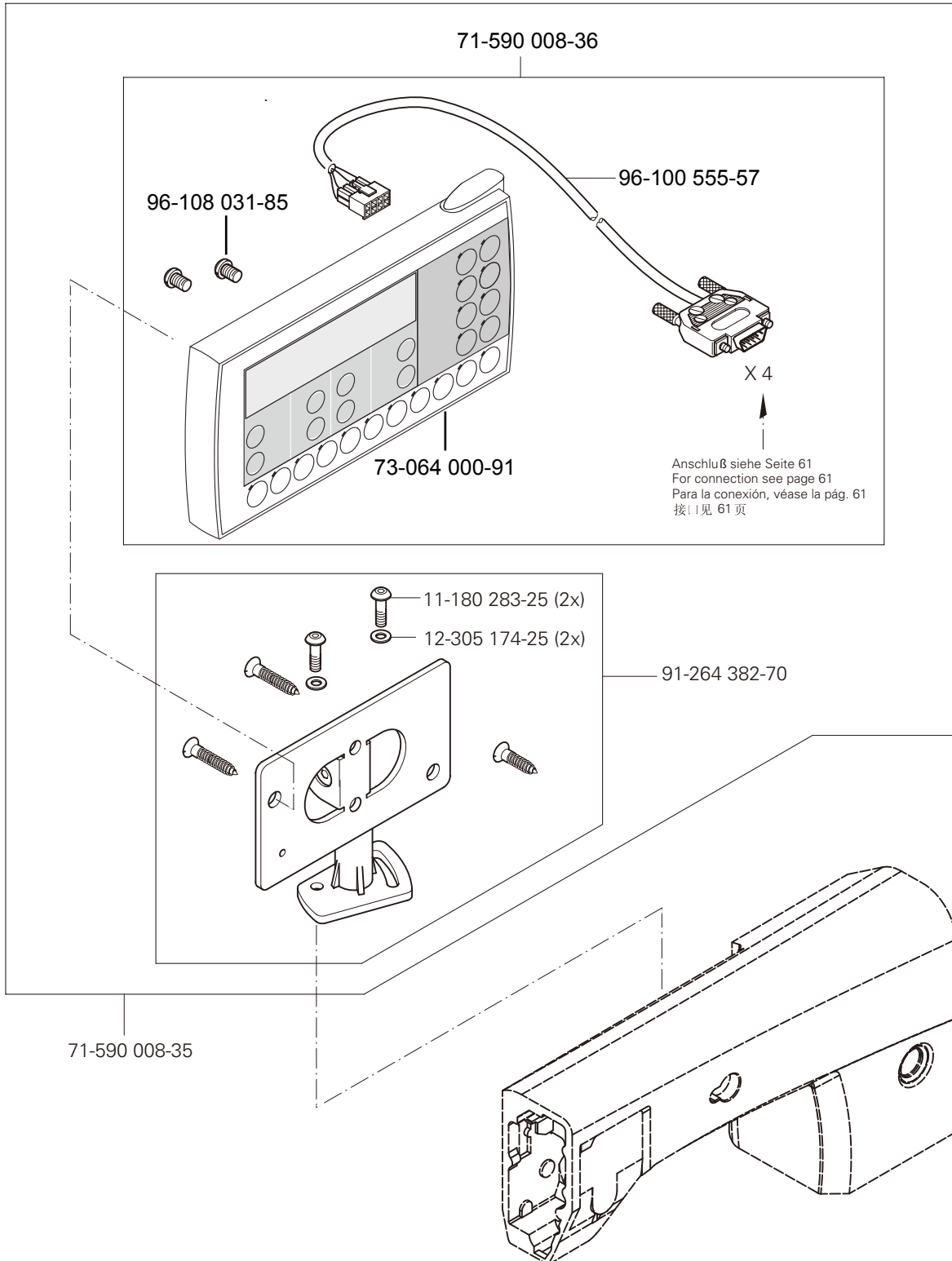
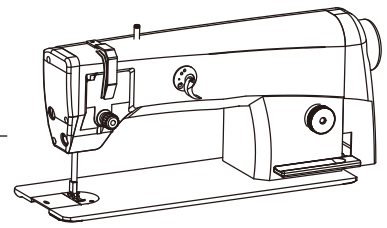

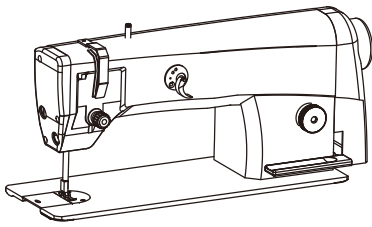

Steuerungspaket Mauser Drive mit MA 350 ED
 Control package Mauser Drive with MA 350 ED
 Paquete de control Mauser Drive con MA 350 ED
 控制组件 Mauser Drive 带 MA 350 ED

MA 2081-948/26
 MA 2083-948/26

13.10

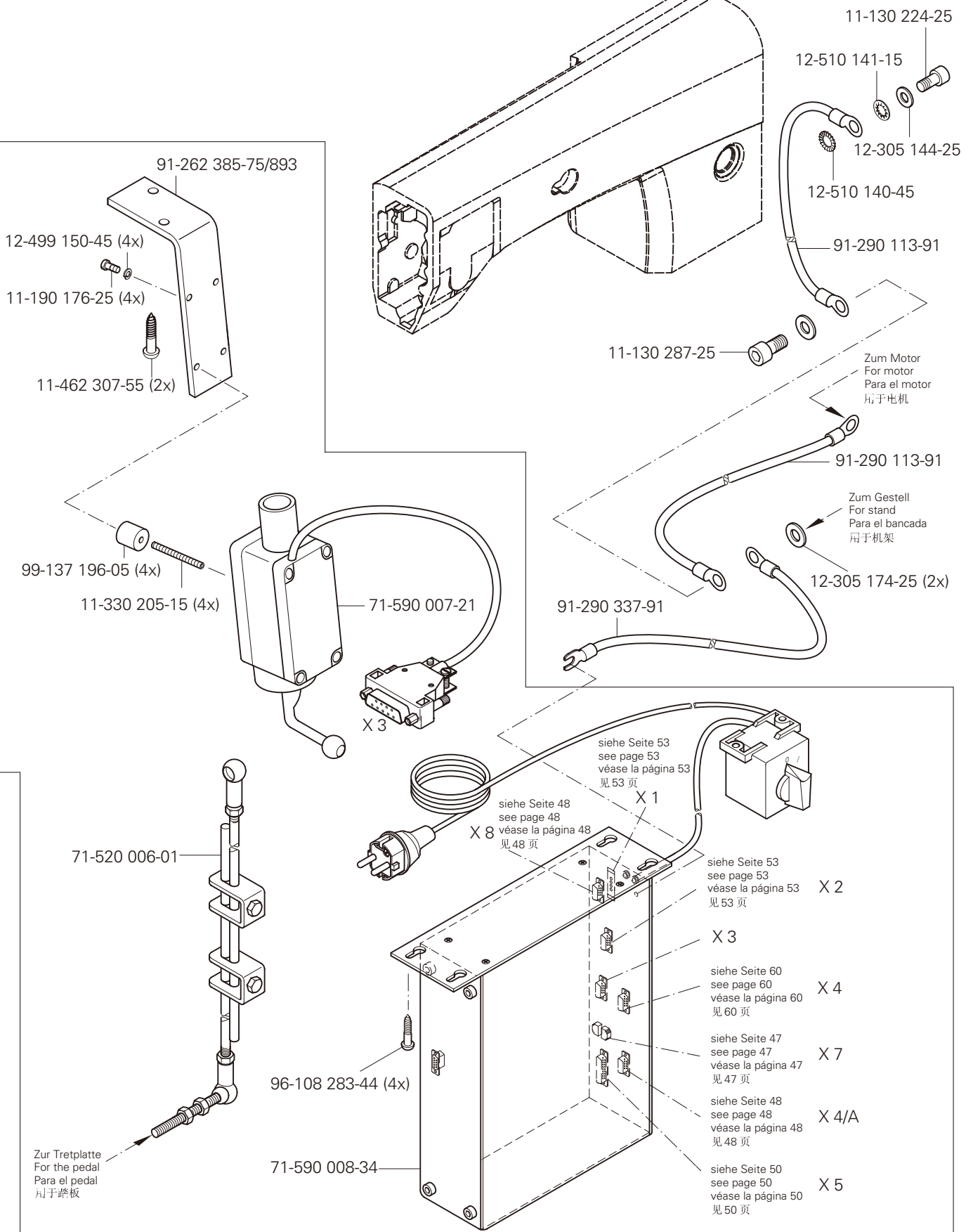

94-000 386-75

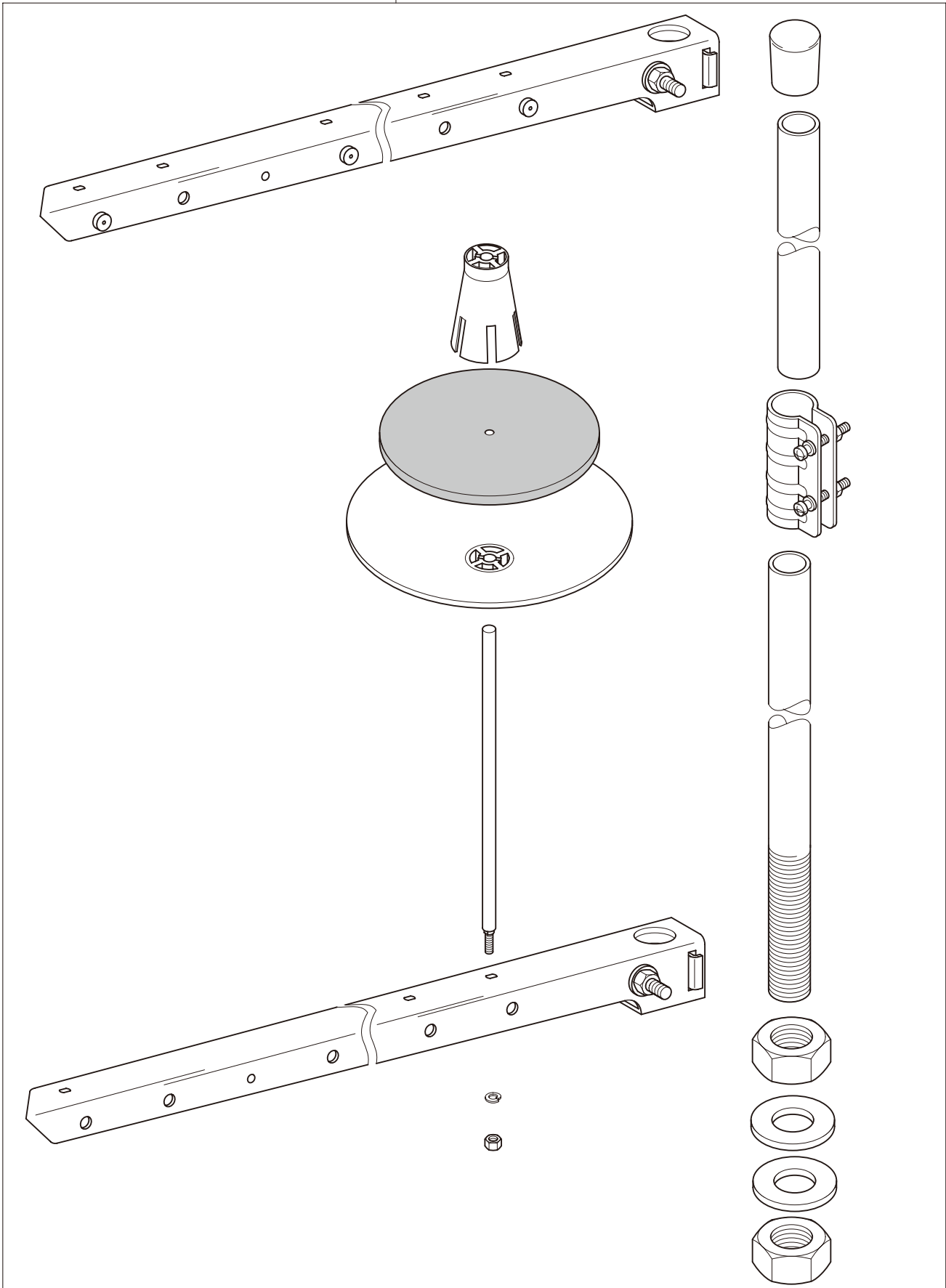

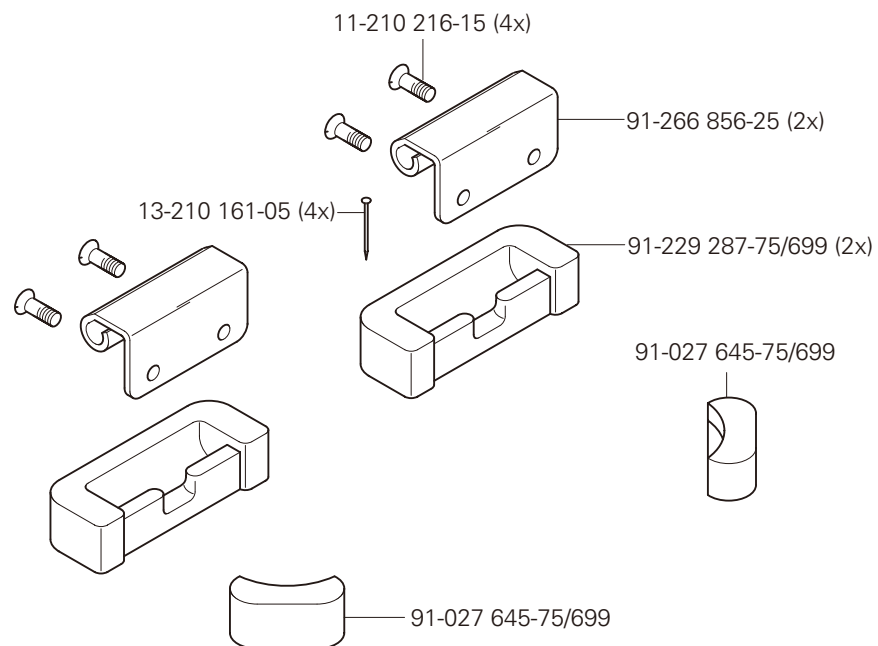
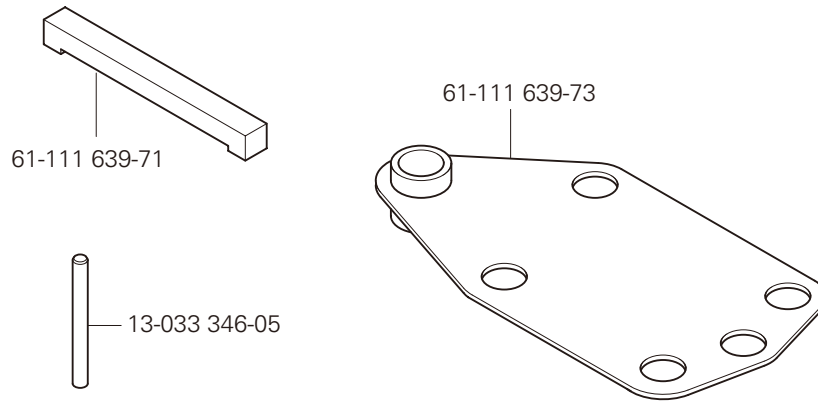

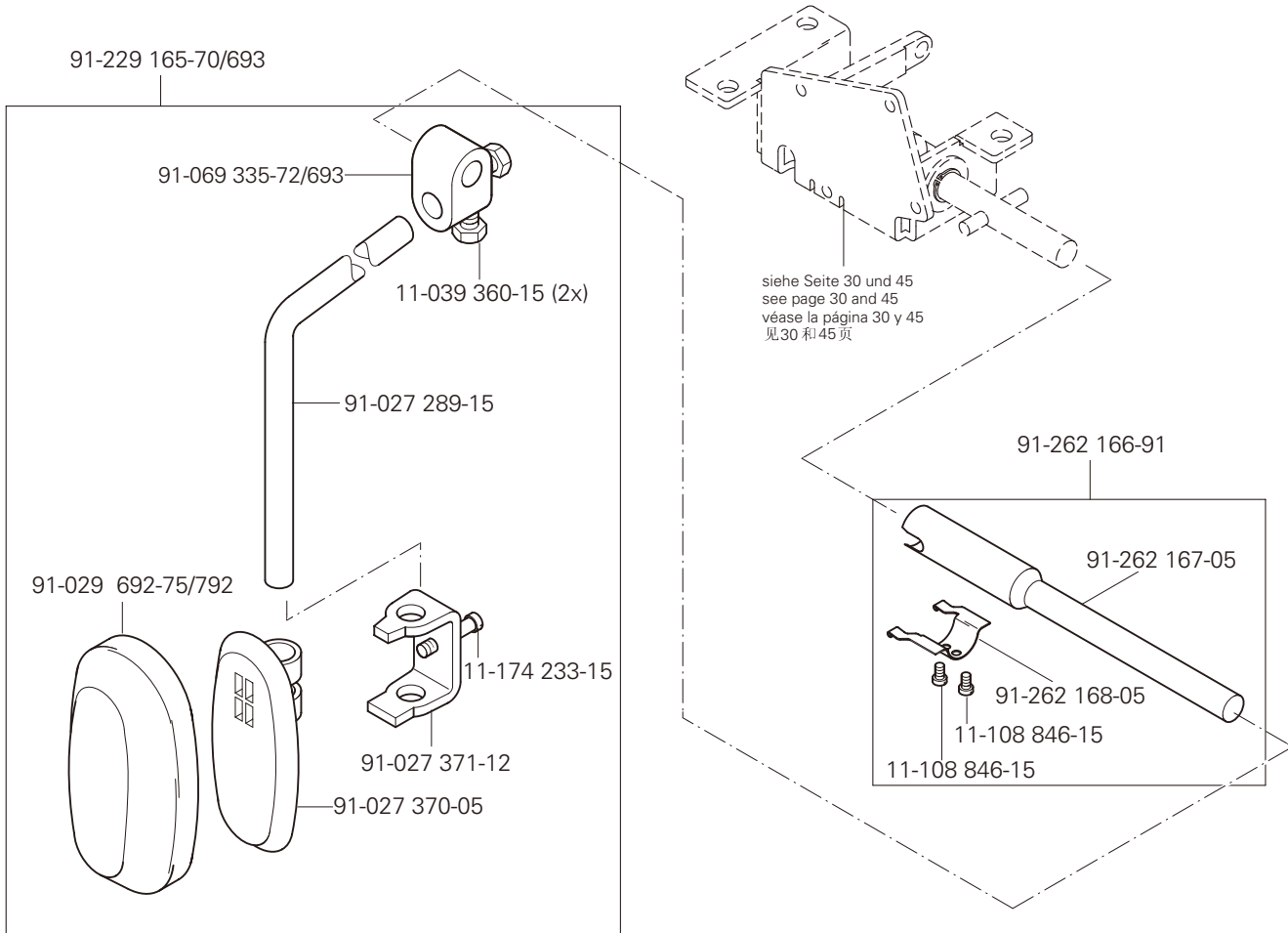
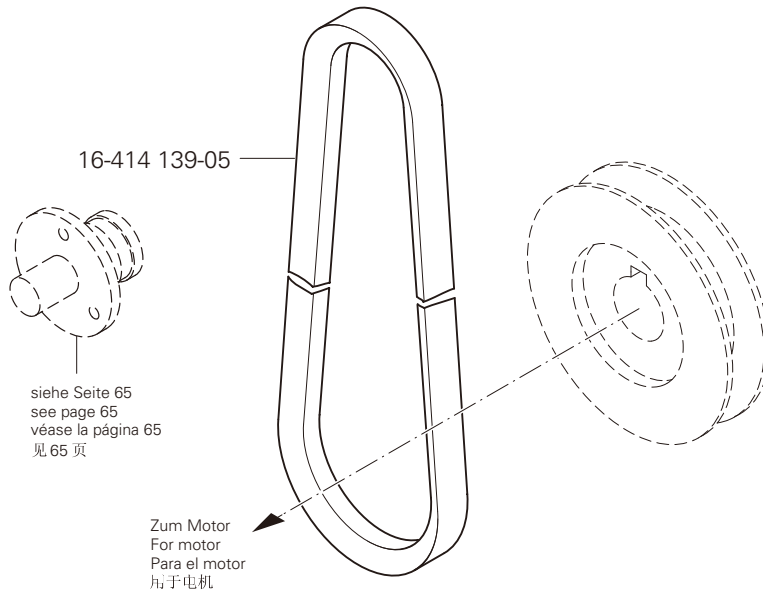

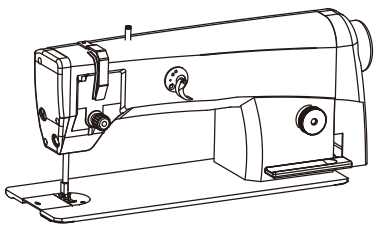

Anbausatz für externen Motor
 Mounting kit for external motor
 Juego de piezas acoplables para motor externo
 外部电机安装组件

MA 2081;2083
 MA 2081- D ;2083- D

19.01

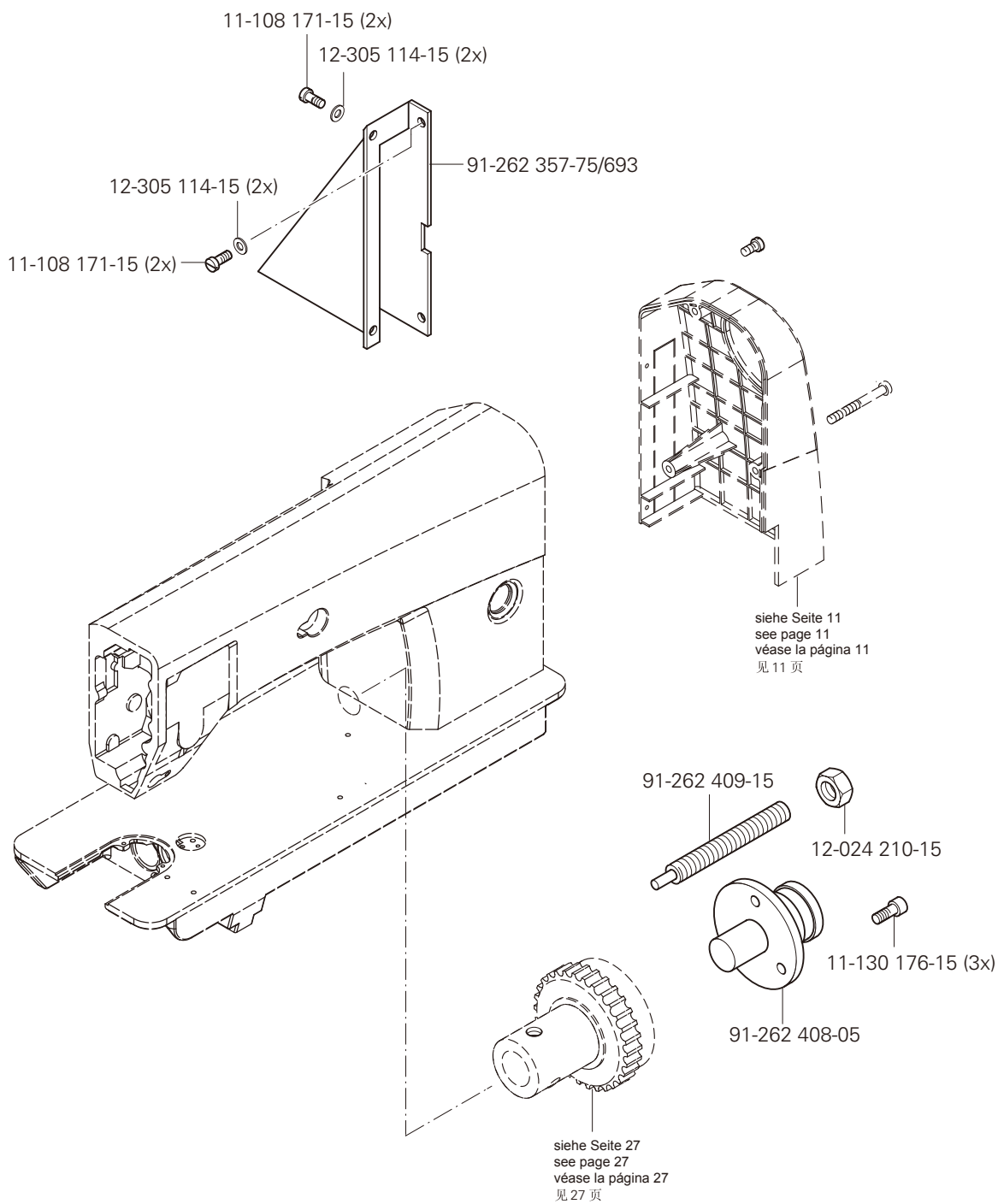

Öl Oil Aceite 油	Mittelpunkts-Viskosität bei: Mean viscosity at: Viscosidad media a: 中点粘度:		Dichte bei: Density of: Densidad a: 密度, 在:		Bestellnummer für Behälter mit: Part number for can with: Número de pedido para recipientes con: 订货号用于油箱, 带:		
	°C	mm ² /s	°C	g/cm ³ (g/ml)	1 Liter 1 Litro 1 升		
28-011 201-44	40	22,0	15	0,865	91-129 917-91		

Fett Grease Grasa 脂	Penetration Penetration Penetración 贯入度	Tropfpunkt Drip-point Punto de goteo 滴点	Bestellnummer für Behälter mit: Part number for can with: Número de pedido para recipientes con: 订货号用于油箱, 带:				
			mm/10	°C	0,25 kg	0,5 kg	1 kg
28-011 202-05							28-011 202-05
28-011 202-47	220-250	185					28-011 202-47

Reinigungsmittel Cleansing agent Limpiadores 清洁剂	Bestellnummer für Behälter mit: Part number for can with: Número de pedido para recipientes con: 订货号用于油箱, 带:		
	240 ml		
Isoprophyl-Alkohol / 异丙醇	95-665 735-91		

No. 零件号	Seite Page Página 页号	No. 零件号	Seite Page Página 页号	No. 零件号	Seite Page Página 页号	No. 零件号	Seite Page Página 页号
11-039 360-15	64	11-130 233-15	35, 38	11-225 292-15	48	11-460 250-15	54
11-039 378-15	44	11-130 251-15	11	11-250 084-15	23	11-714 031-91	48
11-106 104-55	52	11-130 257-25	11	11-317 971-15	14	12-005 154-15	36, 40
11-108 021-15	48	11-130 284-15	24	11-320 171-15	20	12-005 175-15	19, 20
11-108 084-15	33, 41	11-130 287-15	18, 19, 20, 30, 42, 45, 46	11-330 085-15	13	12-005 195-15	38,
11-108 084-25	49	11-130 287-25	57, 59, 61,	11-330 166-15	18, 48,	12-005 215-15	44, 45, 46, 48
11-108 087-15	41	11-130 293-15	11, 45, 46	11-330 175-15	23, 40	12-024 121-25	52,
11-108 096-15	39	11-130 299-25	49	11-330 205-15	57, 59, 61,	12-024 171-15	30, 45
11-108 111-15	52	11-130 305-25	34	11-330 217-15	25, 26, 32, 33, 39, 41	12-024 191-15	34, 38, 48,
11-108 135-15	38	11-130 326-25	49	11-330 220-15	12, 13, 14, 15, 31, 38,	12-024 191-25	23, 47,
11-108 171-15	65	11-130 329-25	49	11-330 232-15	30, 45,	12-024 210-15	65
11-108 174-15	50	11-130 365-15	53	11-330 277-15	16, 18, 20, 21, 28, 37, 44, 48,	12-305 084-25	47,
11-108 174-25	12	11-132 172-15	12	11-330 280-15	16	12-305 114-15	15, 42, 48, 52, 65,
11-108 177-15	29	11-132 223-15	12, 34	11-330 952-15	18, 22, 23, 24, 30, 38, 45	12-305 144-15	48, 49
11-108 222-15	25, 26, 41	11-170 281-15	17	11-330 955-15	14, 34, 38, 48, 49	12-305 144-25	57, 59, 61,
11-108 222-25	11	11-174 176-15	38, 39,	11-330 958-15	37,	12-305 174-25	49, 56, 57, 58, 59, 60, 61,
11-108 846-15	64	11-174 233-15	64	11-330 960-15	53	12-305 264-15	30, 45
11-108 858-15	48	11-178 172-15	39	11-330 962-15	24, 42	12-315 080-15	52
11-130 086-15	36, 40	11-178 223-25	20	11-330 964-15	16, 25, 26, 27, 33, 41	12-325 160-15	49, 50
11-130 092-25	47	11-180 283-25	11, 38, 56, 58, 60,	11-330 968-15	27	12-335 171-15	19
11-130 167-15	34	11-190 176-25	57, 59, 61,	11-335 085-15	33, 41	12-341 090-25	22
11-130 170-25	11, 48, 51	11-210 168-15	23	11-335 280-15	16, 19, 21, 27	12-349 901-05	26, 33, 41
11-130 173-15	11, 38, 39, 42, 48, 52,	11-210 216-15	49	11-341 277-15	12, 14, 15, 22	12-360 023-05	52
11-130 176-15	15, 24, 38, 42, 45, 46, 48, 65	11-210 265-15	16	11-341 901-15	14	12-360 043-05	34, 42, 49,
11-130 179-15	48	11-225 172-25	11	11-341 902-15	27	12-360 054-05	19, 20
11-130 185-15	11	11-225 178-25	49	11-341 902-15	27	12-360 063-05	20, 22, 35
11-130 203-15	34	11-225 220-15	34	11-341 904-15	12, 48	12-360 064-05	13, 27, 31
11-130 224-15	18, 22, 27, 30, 36, 38, 40, 45	11-225 223-15	13, 31	11-460 163-15	54	12-360 064-15	48,
11-130 224-25	11, 57, 59, 61	11-225 226-15	49			12-360 083-05	21
11-130 227-15	20, 39, 49,	11-225 232-15	12, 36, 40				

No. 零件号	Seite Page Página 页号	No. 零件号	Seite Page Página 页号	No. 零件号	Seite Page Página 页号	No. 零件号	Seite Page Página 页号
12-360 143-05	18	13-030 341-05	11,	61-111 639-71	63	91-002 134-05	32
12-499 150-45	57, 59, 61,	13-033 190-05	33, 41	61-111 639-73	63	91-004 181-05	24, 47
12-499 170-45	49	13-033 208-05	22	71-120 006-31	52	91-009 035-25	23
12-499 190-45	42	13-033 346-05	63	71-120 006-33	48	91-019 929-05	32
12-510 140-45	57, 59, 61,	13-052 085-55	16, 18	71-130 006-39	51	91-020 324-05	42
12-510 141-15	57, 59, 61,	13-063 193-05	25, 26, 41	71-170 002-20	36,40	91-027 289-15	64
12-610 190-45	17, 18, 24, 34	13-064 247-05	12	71-170 002-21	45, 46	91-027 370-05	64
12-610 200-45	19, 39,	13-068 391-05	21	71-170 002-24	42	91-027 371-12	64
12-610 210-45	13, 31,	13-210 161-05	63	71-370 001-08	54	91-027 645-75/699	63
12-610 230-45	25, 26, 30, 33, 41, 45,	13-250 088-25	14	71-370 001-31	34	91-029 692-75/792	64
12-610 280-45	28	13-250 097-25	15	71-370 001-32	52	91-056 192-25	23, 40, 47
12-618 170-45	11	14-012 903-01	48, 49,	71-370 001-35	48, 50,	91-056 193-25	23, 40, 47
12-618 190-45	23	14-016 080-01	25, 26, 33, 41	71-370 002-92	54	91-056 197-91	40
12-618 210-45	45, 46	14-016 101-91	27	71-520 000-70	48,	91-056 198-21	40
12-624 200-45	36, 40	14-016 151-91	16	71-520 006-01	57, 59, 61,	91-056 578-91	23
12-624 210-45	12	14-016 171-91	27	71-523 555-76	53	91-056 760-05	40
12-624 280-45	18	14-018 624-91	16	71-590 007-21	57, 59, 61,	91-069 075-11	12
12-624 310-45	28	14-018 624-91	16	71-590 007-84	55, 56	91-069 079-72/937	12
12-640 090-55	38	14-026 902-01	16	71-590 007-89	55, 58	91-069 105-25	12
12-640 130-55	12, 23, 34, 36, 52,	14-218 906-01	49	71-590 008-33	55,	91-069 322-01	12
12-640 150-55	17, 20, 42,	14-602 901-01	23	71-590 008-34	61	91-069 335-72/693	64
12-640 170-55	20, 38	16-409 981-05	49	71-590 008-35	55, 60	91-069 371-92	39,
12-640 200-55	22, 38,	16-414 139-05	64	71-590 008-36	56, 58, 60	91-069 434-91	12
12-650 012-55	21	25-161 801-49	14, 15, 41	71-770 000-63	52	91-069 483-05	38,
12-660 390-45	25, 26, 33, 41	25-161 801-52	14, 15, 26, 33	73-064 000-91	56, 58, 60	91-069 484-05	38,
12-710 190-02	42	26-536 301-09	14, 15, 26, 33, 41	74-061 788-91	57	91-069 486-05	39,
12-710 901-22	20	28-011 201-44	66	74-061 790-91	59	91-069 489-12	39,
12-710 904-12	30, 45	28-011 202-05	66	91-000 250-15	32	91-069 490-11	38,
12-710 913-12	48	28-011 202-47	66	91-000 390-05	32	91-069 493-11	38,
				91-000 621-15	24, 47	91-069 496-05	38,
				91-001 824-05	38	91-069 498-11	39,
						91-069 501-15	39,

No. 零件号	Seite Page Página 页号	No. 零件号	Seite Page Página 页号	No. 零件号	Seite Page Página 页号	No. 零件号	Seite Page Página 页号
91-069 554-12	24	91-162 984-05	12	91-175 557-11	40	91-262 237-91	26
91-069 562-05	12	91-165 685-05	33, 41	91-175 690-05	32	91-262 250-91	26
91-069 568-05	12	91-166 452-21	23	91-175 785-05	32	91-262 273-05	45, 46
91-069 577-91	38,	91-167 590-15	11	91-229 165-70/693	64	91-262 274-05	21
91-069 579-05	12, 36	91-168 347-05	28	91-229 180-90	54	91-262 277-05	24
91-069 585-25	23	91-168 480-15	16	91-229 287-75/699	63	91-262 300-91	24
91-069 598-11	38,	91-169 457-12	14	91-262 161-72/693	16	91-262 301-12	24
91-069 599-15	38,	91-169 474-05	39	91-262 164-12	30, 45	91-262 304-45	13
91-069 600-15	38,	91-169 475-15	38	91-262 166-91	64	91-262 320-91	15
91-069 601-15	38,	91-169 556-05	17, 18, 24	91-262 167-05	64	91-262 326-15	11
91-069 630-91	38,	91-171 042-05	23	91-262 168-05	64	91-262 329-75/937	11
91-069 632-05	38,	91-171 049-05	23	91-262 174-11	17	91-262 331-91	25, 26
91-069 709-12	14	91-171 050-05	12	91-262 179-15	17	91-262 344-91	18
91-069 789-15	39,	91-171 068-05	12	91-262 185-05	41	91-262 345-12	18
91-100 076-15	47	91-171 173-92	25, 26, 33, 41	91-262 187-15	25, 26, 41	91-262 346-12	18
91-100 117-15	12, 36	91-171 409-12	28	91-262 188-15	33, 41	91-262 347-05	18
91-100 270-25	22,	91-171 441-01	18	91-262 189-91	41	91-262 354-05	13, 31
91-100 281-25	23	91-171 785-05	33, 41	91-262 195-92	16	91-262 355-12	22
91-100 331-15	17	91-171 811-15	17	91-262 196-05	16	91-262 357-75/693	65
91-100 400-15	16	91-172 676-05	28	91-262 197-05	22	91-262 360-05	25, 26, 41
91-105 482-05	22	91-174 002-05	49	91-262 202-15	22	91-262 372-92	45, 46
91-107 265-05	39,	91-174 284-01	49	91-262 203-05	22	91-262 376-91	26
91-118 570-92	16	91-174 480-05	32	91-262 208-05	33, 41	91-262 377-91	25, 26
91-118 683-05	23	91-174 507-05	32	91-262 209-91	41	91-262 385-75/893	57, 59, 61,
91-118 711-05	24, 34, 38	91-174 703-91	32	91-262 214-05	25, 26, 41	91-262 408-05	65
91-125 009-05	39	91-174 783-05	23	91-262 218-05	20	91-262 409-15	65
91-129 917-91	66	91-174 851-05	40	91-262 225-91	41	91-262 437-05	25, 26
91-140 945-05	32	91-174 879-05	23, 47	91-262 228-01	29	91-262 446-15	44
91-161 334-25	12	91-174 955-91	32	91-262 231-72/693	21	91-262 447-05	44
91-162 583-75/937	11	91-174 956-45	32	91-262 232-11	21	91-262 457-12	12
91-162 596-25	12	91-175 203-05	28	91-262 235-15	41	91-262 465-15	30, 45, 46
91-162 690-92	12	91-175 265-12	48				
91-162 694-05	12						

No. 零件号	Seite Page Página 页号	No. 零件号	Seite Page Página 页号	No. 零件号	Seite Page Página 页号	No. 零件号	Seite Page Página 页号
91-262 536-15	11	91-262 813-91	20	91-262 940-91	36	91-264 200-75/937	49
91-262 544-91	16	91-262 819-05	15	91-262 941-91	12	91-264 212-91	38
91-262 552-12	22	91-262 821-91	13	91-262 958-15	36, 40	91-264 213-12	38
91-262 554-92	18	91-262 824-96	24	91-262 962-91	36	91-264 214-05	38
91-262 565-92	37	91-262 825-91	24	91-262 964-91	12	91-264 222-15	27
91-262 566-05	27	91-262 837-91	14	91-262 983-75/699	48	91-264 233-15	11
91-262 566-92	27	91-262 838-91	18	91-262 985-25	11	91-264 236-01	49
91-262 569-91	40	91-262 839-91	18	91-264 132-75/937	37	91-264 240-05	41
91-262 573-05	30, 45	91-262 842-92	25, 26, 33, 41	91-264 133-75/937	38,	91-264 250-05	49
91-262 576-05	53	91-262 857-15	48	91-264 134-91	39,	91-264 254-16	24
91-262 577-75/693	22	91-262 860-92	48	91-264 136-05	38	91-264 255-91	28
91-262 579-15	45, 46	91-262 863-15	49	91-264 139-72/937	39	91-264 258-91	24
91-262 677-12	30, 45	91-262 865-92	49	91-264 140-15	38	91-264 293-91	19
91-262 678-91	40	91-262 871-05	49	91-264 141-91	37	91-264 299-91	25
91-262 679-91	45	91-262 872-91	48	91-264 146-05	38	91-264 300-91	25
91-262 680-91	30	91-262 880-91	46	91-264 147-71/937	39	91-264 301-91	20
91-262 686-91	24	91-262 882-15	36	91-264 154-25	24	91-264 304-05	20
91-262 687-25	24	91-262 893-91	35	91-264 156-05	35	91-264 306-12	20
91-262 691-90	13	91-262 899-75/896	34	91-264 166-01	49	91-264 310-91	25
91-262 691-91	13	91-262 900-05	35	91-264 167-05	49	91-264 338-15	41
91-262 692-05	13, 31	91-262 905-91	36	91-264 170-01	49	91-264 340-11	17
91-262 751-90	13	91-262 908-05	35	91-264 173-01	49	91-264 355-91	20
91-262 751-91	13	91-262 916-91	48	91-264 186-91	34	91-264 357-05	23
91-262 770-05	34	91-262 919-05	48	91-264 187-91	34	91-264 358-05	23
91-262 790-15	36	91-262 920-91	48	91-264 189-71/896	35	91-264 364-05	53
91-262 791-05	36	91-262 924-05	48	91-264 192-91	52	91-264 365-91	53
91-262 792-05	36	91-262 926-11	34	91-264 193-11	52	91-264 382-70	56, 58, 60,
91-262 804-91	24	91-262 929-15	34	91-264 196-05	52	91-264 383-91	26
91-262 805-25	24	91-262 930-05	34	91-264 197-05	52	91-264 769-92	34
91-262 806-05	24, 47	91-262 931-05	34			91-265 065-05	33, 41
						91-265 189-05	24

No. 零件号	Seite Page Página 页号	No. 零件号	Seite Page Página 页号	No. 零件号	Seite Page Página 页号	No. 零件号	Seite Page Página 页号
91-265 198-15	17	95-774 620-05	33	96-200 415-91	42	99-069 722-01	14
91-265 227-05	32	95-774 630-05	49	96-200 417-01	42	99-133 220-01	14
91-265 262-91	32	95-774 646-05	20	96-200 419-05	42	99-134 544-55	49
91-265 270-91	32	95-774 647-05	48	96-200 420-05	42	99-135 161-85	21
91-266 397-01	23	95-774 652-91	31	96-202 403-75/693	11	99-137 151-45	23
91-266 856-25	63	95-774 662-90	31	96-202 404-75/693	11	99-137 186-05	25, 26
91-268 076-15	26, 33, 41	95-774 663-91	33	96-202 405-75/693	11	99-137 187-15	25, 26
91-290 113-91	57, 59, 61,	95-774 664-91	33	96-202 406-75/937	11	99-137 188-15	25, 26
91-290 337-91	57, 59, 61,	95-774 666-91	33	96-202 407-05	27	99-137 190-05	25, 26
91-292 276-91	48,	95-774 667-91	33	96-202 408-01	16	99-137 191-05	25, 26
91-700 335-25	11, 37, 43	95-774 668-15	33	96-202 410-05	22	99-137 192-05	25, 26
91-700 785-15	28	95-774 669-12	48	96-202 411-01	14	99-137 193-05	25, 26
91-700 996-15	23	95-774 670-75/937	48	96-202 412-04	28	99-137 194-05	25, 26
91-701 179-15	24	95-774 672-05	48	96-202 413-15	17	99-137 196-05	57, 59, 61,
91-701 346-15	39	95-774 673-71/937	48	96-202 418-92	27	99-137 247-45	11
91-701 391-15	39	95-774 680-75/937	11	96-202 422-91	43	99-137 341-01	34
94-000 386-75	62	95-774 685-15	48	96-202 431-91	22	99-137 405-15	25
95-665 735-91	66	95-774 686-91	49	96-202 433-02	44	99-137 415-05	26
95-669 358-05	26, 33, 41	95-774 696-05	43	96-202 434-05	25, 26, 33, 41		
95-774 317-05	42	95-784 321-91	48	96-202 435-71/937	11		
95-774 327-91	11	95-784 333-91	50	96-202 436-91	14		
95-774 361-05	47	96-100 555-57	56, 58, 60	96-202 437-91	16		
95-774 459-25	47	96-100 651-16	54	96-202 438-91	16		
95-774 460-91	47	96-108 031-85	56, 58, 60	96-202 439-91	17		
95-774 464-05	23	96-108 283-44	54, 57, 59 61	96-202 440-71/693	22		
95-774 465-25	23			96-202 441-91	25, 26, 41		
95-774 466-91	23			96-202 442-91	26		
95-774 467-05	23	96-200 407-91	42	96-202 454-75/937	49		
95-774 508-91	27	96-200 408-91	42	96-202 455-71/937	38		
95-774 524-91	47	96-200 409-91	42				
95-774 525-91	47	96-200 410-05	27	96-202 46591	41		
95-774 612-92	22	96-200 412-01	42				



MA 2081

MA 2083

Unterklassen-Ausstattung

Subclass parts

Composición de las subclases

子机型-设备

22.01 Nähwerkzeuge▲ Gauge parts Organos de costura MA 2081 缝纫工具 MA 2081-D

-8/11

Für allgemeine Näharbeiten.
Standard form des Teilesatzes.
(Zum Nähen mittlerer
Materialien.)

For ordinary sewing operations.
Standard part set.
(for sewing medium- weight
materials.)

Para trabajos de costura en general.
Juego de piezas estándar.
(para coser materiales semiligeros.)

适用于一般性缝纫工作。
套件的标准型式。
(用于中偏厚料的缝纫)

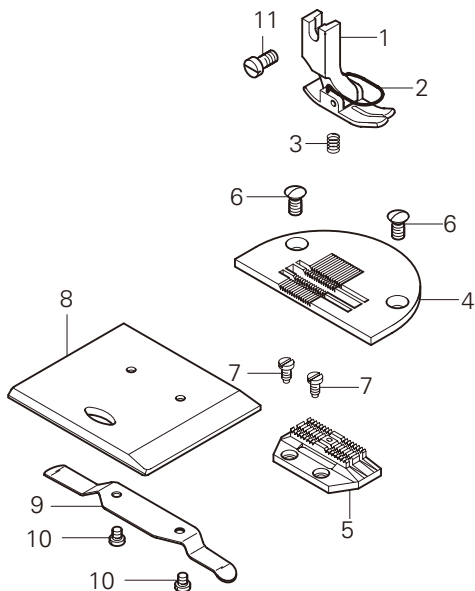

Pos.-Nr. Item No. 序号	Ausführung Model Tipo 款式	Stichlänge Stitch length Largo de puntada 针距	Teile-Nr. Part No. 零件号
1 - 10	B♦	4,5	91-202 308-91
1 - 3	B♦	4,5	91-154 804-21
2			91-154 744-05 [3/1]
3			91-154 518-05
4	B♦	4,5	91-150 671-25
5	B♦	4,5	91-059 816-05
6			91-264 154-25
7			91-701 179-15
8 - 10			91-262 686-91
8			91-262 687-25
9			91-004 181-05
10			91-000 621-15
11			11-108 174-15

22.01 Nähwerkzeuge▲ Gauge parts Organos de costura MA 2081 缝纫工具 MA 2081-G

-8/13

Für allgemeine Näharbeiten.
Standard form des Teilesatzes.
(Zum Nähen mittelschwerer
Materialien.)

For ordinary sewing operations.
Standard part set.
(for sewing medium-heavy
materials.)

Para trabajos de costura en general.
Juego de piezas estándar.
(para coser materiales semipesados.)

适用于一般性缝纫工作。
套件的标准型式。
(用于中偏厚料的缝纫)

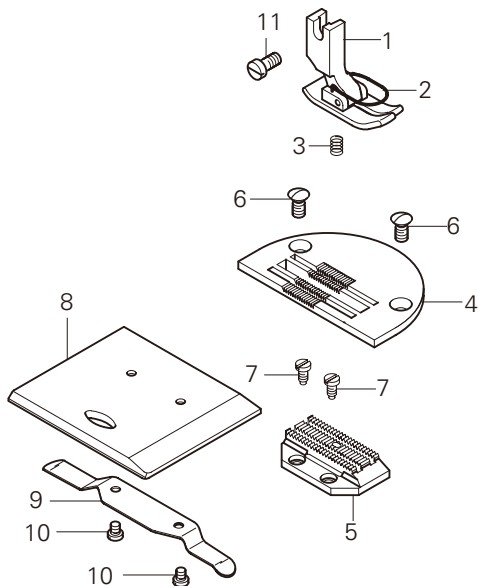

Pos.-Nr. Item No. 序号	Ausführung Model Tipo 款式	Stichlänge Stitch length Largo de puntada 针距	Teile-Nr. Part No. 零件号
1 - 10	C♦	6,0	91-202 310-93/001
1 - 3	C♦	6,0	91-154 838-23/001
2			91-154 744-05 [3/1]
3			91-154 518-05
4	C♦	6,0	91-150 672-25
5	C♦	6,0	91-059 961-05
6			91-264 154-25
7			91-701 179-15
8 - 10			91-262 686-91
8			91-262 687-25
9			91-004 181-05
10			91-000 621-15
11			11-108 174-15

Nähwerkzeuge[▲]

Gauge parts

Organos de costura

缝纫工具

MA 2081-948/26

MA 2081- D-948/26

22.01

-8/92

Für allgemeine Näharbeiten mittels Brücken-Teilesatz. (Zum Nähen mittlerer Materialien.)

For ordinary sewing operations with bridge-type part set. (for sewing medium-weight materials.)

Para trabajos de costura en general juego de piezas en puente. (para coser materiales semiligeros.)

适用于借助桥形杆组件的一般性缝纫工作。(用于中厚料的缝纫)

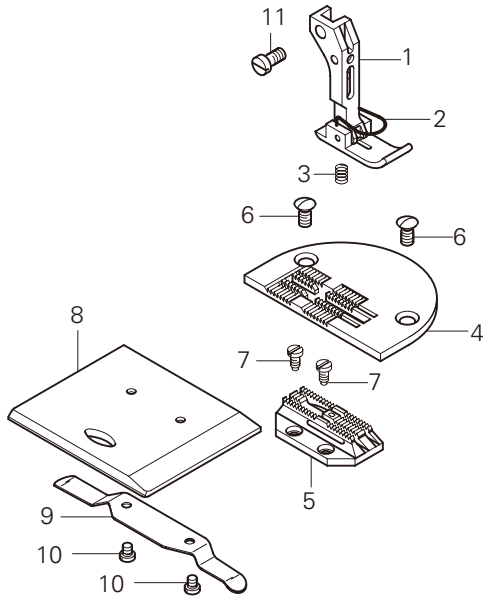

Pos.-Nr. Item No. N° de pos. 序号	Ausführung Model Tipo 款式	Stichlänge Stitch length Largo de puntada 针距	Teile-Nr. Part No. N° de pieza 零件号
1 - 10	B♦	4,5	91-202 453-93/001
1 - 3	B♦	4,5	91-154 832-21
2			91-054 894-05 [3/1]
3			91-154 518-05
4	B♦	4,5	91-150 673-25
5	B♦	4,5	91-059 505-05
6			91-264 154-25
7			91-701 179-15
8 - 10			91-262 686-91
8			91-262 687-25
9			91-004 181-05
10			91-000 621-15
11			11-108 174-15

Nähwerkzeuge[▲]

Gauge parts

Organos de costura

缝纫工具

MA 2081

22.01

-34/11

Zum Nähen besonders feiner Stoffe.

For stitching delicate fabrics.

Para géneros muy finos mediante.

适用于缝纫特薄材料。

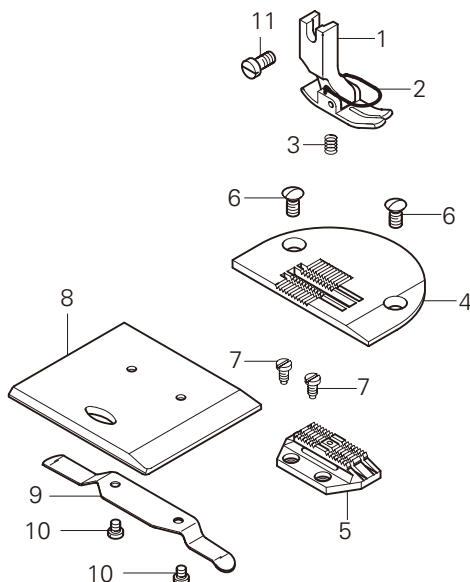

Pos.-Nr. Item No. N° de pos. 序号	Ausführung Model Tipo 款式	Stichlänge Stitch length Largo de puntada 针距	Teile-Nr. Part No. N° de pieza 零件号
1 - 10	A♦	3,0	91-202 450-91
1 - 3	A♦	3,0	91-154 804-21
2			91-154 744-05 [3/1]
3			91-154 518-05
4	A♦	3,0	91-150 819-25
5	A♦	3,0	91-059 496-05
6			91-264 154-25
7			91-701 179-15
8 - 10			91-262 686-91
8			91-262 687-25
9			91-004 181-05
10			91-000 621-15
11			11-108 174-15

□ / ♦ siehe Kapitel 2 Erläuterung der Schlüsselzeichen
see chapter 2 Explanation of key markings
véase el Cap. 2 Explicaciones de los signos clave
见第2章标记说明

▲ Weitere Unterklassen und Ausführungen auf Anfrage
Further Subclasses and versions on enquiry
Otras subclases y tipos, sobre demanda
更多的子机型和款式请咨询

22.01 Nähwerkzeuge ▲ Gauge parts Organos de costura 缝纫工具

MA 2081-948/26

-34/92

Zum Nähen besonders feiner
Stoffe mittels Brücken-Teilesatz.

For stitching delicate fabrics
with bridge-type part set.

Para géneros muy finos mediante
juego de piezas en puente.

适用于借助桥形杆组件
缝纫特薄材料。

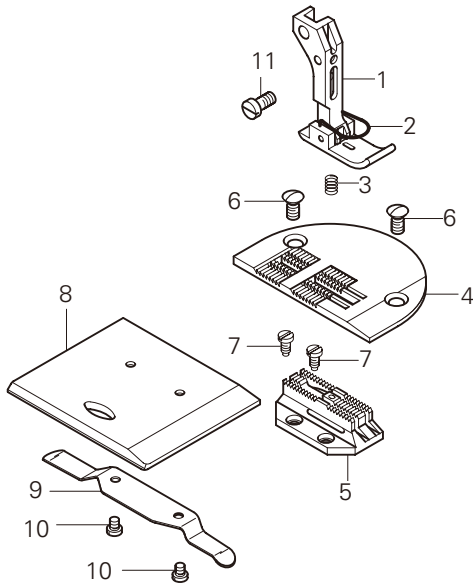

Pos.-Nr. Item No. Nº de pos. 序号	Ausführung Model Tipo 款式	Stichlänge Stitch length Largo de puntada 针距	Teile-Nr. Part No. Nº de pieza 零件号
1 - 10	A♦	3,0	91-202 454-93/001
1 - 3	A♦	3,0	91-154 830-21
2			91-054 894-05 3/1
3			91-154 518-05
4	A♦	3,0	91-150 764-25
5	A♦	3,0	91-059 504-05
6			91-264 154-25
7			91-701 179-15
8 - 10			91-262 686-91
8			91-262 687-25
9			91-004 181-05
10			91-000 621-15
11			11-108 174-15

22.01 Nähwerkzeuge ▲ Gauge parts Organos de costura 缝纫工具

MA 2081

-731/01-8/11

Arbeitsgang
Operation
Opération
工序

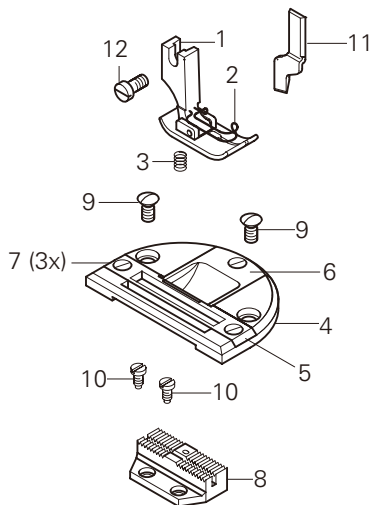
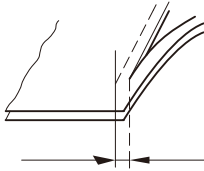

Pos.-Nr. Item No. Nº de pos. 序号	Ausführung Model Tipo 款式	Stichlänge Stitch length Largo de puntada 针距	Schneidabstand Trimming margin Margen de corte 切边距离	Teile-Nr. Part No. Nº de pieza 零件号
1 - 11	♦♦♦♦♦	4,5 4,5 4,5 4,5 4,5 4,5	4,0 4,5 5,0 6,0 7,0	91-202 363-93/003 91-202 363-93/004 91-202 363-93/001 91-202 363-93/005 91-202 363-93/006
1 - 3	♦♦♦♦♦	4,5 4,5 4,5 4,5 4,5	4,0 4,5 5,0 6,0 7,0	91-154 792-03/005 91-154 792-03/006 91-154 792-03/001 91-154 792-03/007 91-154 792-03/008
2				91-154 797-05 3/1
3				91-154 518-05
4 - 7	♦♦♦♦♦	4,5 4,5 4,5 4,5 4,5	4,0 4,5 5,0 6,0 7,0	91-150 676-93/002 91-150 676-93/003 91-150 676-93/001 91-150 676-93/004 91-150 676-93/005
4				91-150 677-05
5	♦♦♦♦♦	4,5 4,5 4,5 4,5 4,5 4,5	4,0 4,5 5,0 6,0 7,0	91-048 716-03/001 91-048 716-03/002 91-048 716-03/003 91-048 716-03/005 91-048 716-03/007
6	♦♦♦♦♦	4,5 4,5 4,5 4,5 4,5	4,0 4,5 5,0 6,0 7,0	91-048 703-04/004 91-048 703-04/005 91-048 703-04/006 91-048 703-04/008 91-048 703-04/010
7				91-000 730-25
8	♦♦♦♦♦	4,5 4,5 4,5 4,5 4,5	4,0 4,5 5,0 6,0 7,0	91-059 833-04/002 91-059 833-04/004 91-059 833-04/006 91-059 833-04/008 91-059 833-04/010
9				91-264 154-25
10				91-701 179-15
11				91-169 395-04/002
12				11-108 174-15

-8/31

Für allgemeine Näharbeiten.
Standard form des Teilesatzes.
(Zum Nähen mittlerer
Materialien.)

For ordinary sewing operations.
Standard part set.
(for sewing medium- weight
materials.)

Para trabajos de costura en general.
Juego de piezas estándar.
(para coser materiales semiligeros.)

适用于一般性缝纫工作。
套件的标准型式。
(用于中厚料的缝纫)

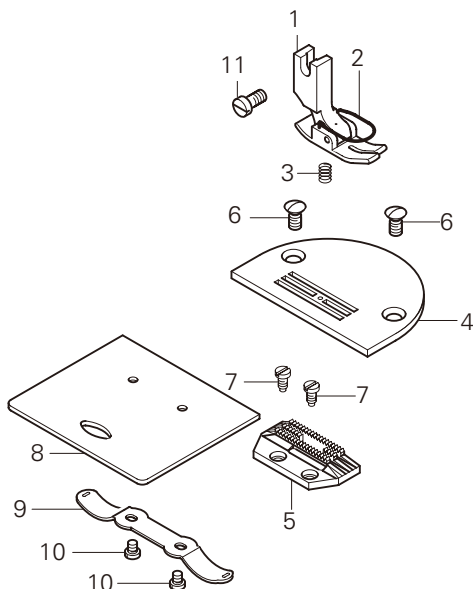

Pos.-Nr. Item No. N° de pos. 序号	Ausführung Model Tipo 款式	Stichlänge Stitch length Largo de puntada 针距	Teile-Nr. Part No. N° de pieza 零件号
1 - 10	B♦	4,5	91-202 356-93/001
1 - 3	B♦	4,5	91-154 807-21
2			91-154 744-05 [3/1]
3			91-154 518-05
4	B♦	4,5	91-150 694-24/001
5	B♦	4,5	91-059 968-05
6			91-264 154-25
7			91-701 179-15
8 - 10			91-262 804-91
8			91-262 805-25
9			91-262 806-05
10			91-000 621-15
11			11-108 174-15

-8/33

Für allgemeine Näharbeiten.
Standard form des Teilesatzes.
(Zum Nähen mittelschwerer
Materialien.)

For ordinary sewing operations.
Standard part set.
(for sewing medium-he avy
materials.)

Para trabajos de costura en general.
Juego de piezas estándar.
(para coser materiales semipesados.)

适用于一般性缝纫工作。
套件的标准型式。
(用于中偏厚料的缝纫)

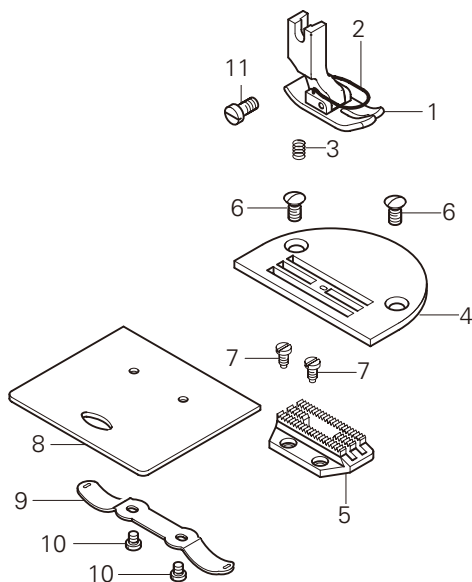

Pos.-Nr. Item No. N° de pos. 序号	Ausführung Model Tipo 款式	Stichlänge Stitch length Largo de puntada 针距	Teile-Nr. Part No. N° de pieza 零件号
1 - 10	C♦	6,0	91-202 357-93/001
1 - 3	C♦	6,0	91-154 845-23/001
2			91-154 744-05 [3/1]
3			91-154 518-05
4	C♦	6,0	91-150 693-25
5	C♦	6,0	91-059 967-05
6			91-264 154-25
7			91-701 179-15
8 - 10			91-262 804-91
8			91-262 805-25
9			91-262 806-05
10			91-000 621-15
11			11-108 174-15

♦ siehe Kapitel 2 Erläuterung der Schlüsselzeichen
see chapter 2 Explanation of key markings
véase el Cap. 2 Explicaciones de los signos clave
见第2章标记说明

▲ Weitere Unterklassen und Ausführungen auf Anfrage
Further Subclasses and versions on enquiry
Otras subclases y tipos, sobre demanda
更多的子机型和款式请咨询

-8/44

Für Stepparbeiten an Schuhschäften und sonstigen Lederwaren mittels Rollfuß

For sewing loperations on shoe uppers and other leather articles; machine equipped with roller presser .

Para trabajos de aparado en cortes de calzado y demás artículos de cuero mediante pie rodante.

适用于滚轮压脚在鞋帮和其它皮料上的珩缝针绣工作。

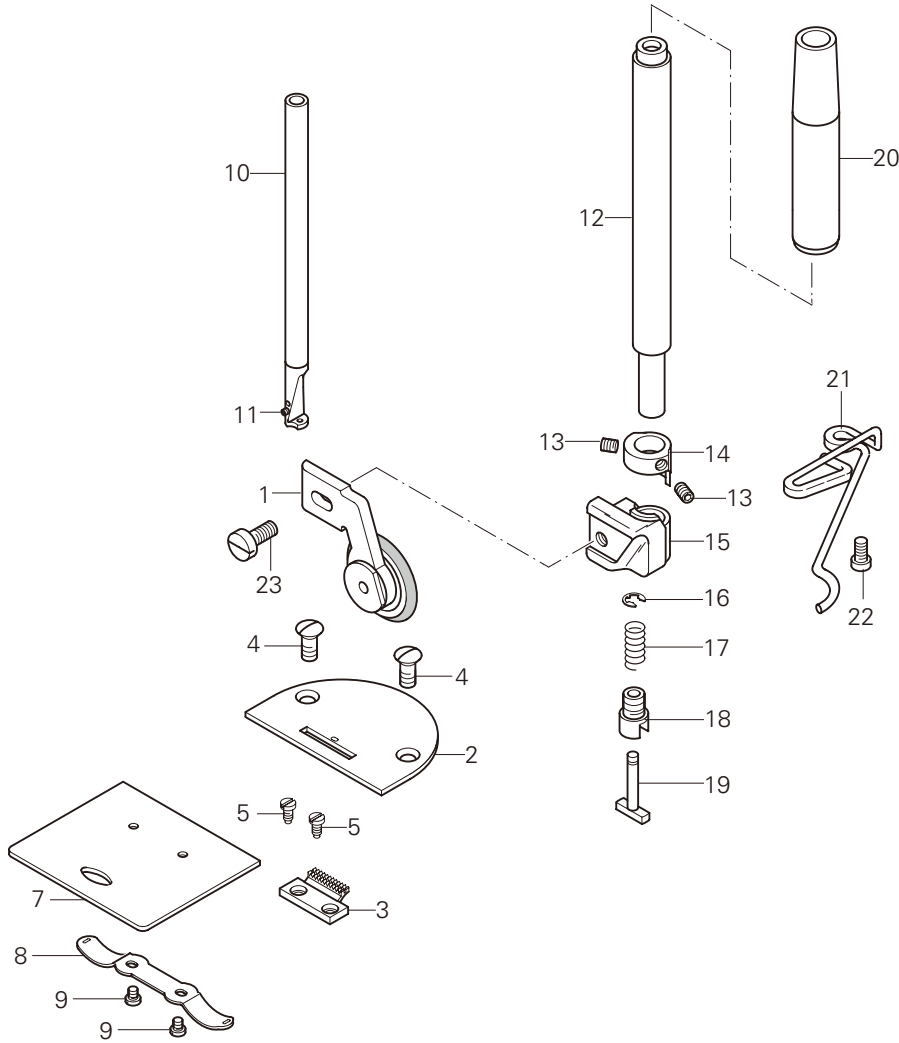

Pos.-Nr. Item No. 序号	Ausführung Model 款式	Stichlänge Stitch length Largo de puntada 针距	Teile-Nr. Part No. 零件号
1 - 9	B♦	4,5	91-202 358-93/002
1	B♦	4,5	91-051 155-93/001
2	B♦	4,5	91-150 695-24/002
3	B♦	4,5	91-059 969-04/002
4			91-264 154-25
5			91-701 179-15
6 - 9			91-262 804-91
7			91-262 805-25
8			91-262 806-05
9			91-000 621-15
10 - 11			91-262 565-92
11			11-330 958-15

Pos.-Nr. Item No. 序号	Ausführung Model 款式	Stichlänge Stitch length Largo de puntada 针距	Teile-Nr. Part No. 零件号
12 - 20			91-171 075-91
12			91-171 076-01
13			91-700 388-15
14			91-169 322-15
15			91-169 323-15
16			12-640 070-55
17			91-025 376-05
18			91-700 409-15
19			91-025 374-05
20			91-171 557-05
21			91-262 520-25
22			11-132 172-15
23			91-700 717-15

-8/93

Für allgemeine Näharbeiten.
Standard form des Teilesatzes.
(Zum Nähen mittlerer
Materialien.)

For ordinary sewing operations.
Standard part set.
(for sewing medium- weight
materials.)

Para trabajos de costura en general.
Juego de piezas estándar.
(para coser materiales semiligeros.)

适用于借助桥形杆组件的
一般性缝纫工作。
(用于中厚料的缝纫)

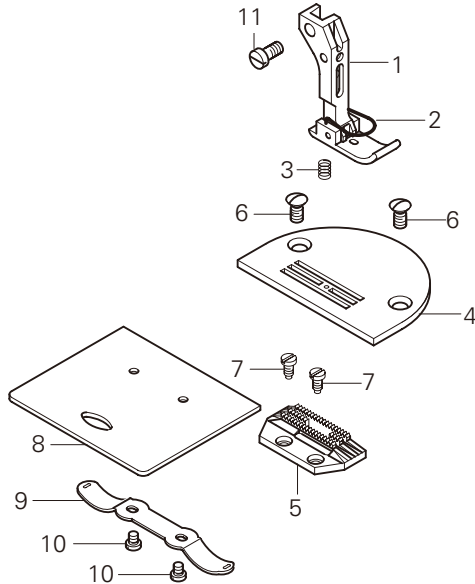

Pos.-Nr. Item No. 序号	Ausführung Model Typo 款式	Stichlänge Stitch length Largo de puntada 针距	Teile-Nr. Part No. 零件号
1 - 10	B♦	4,5	91-202 391-93/001
1 - 3	B♦	4,5	91-154 834-23/002
2			91-054 894-05 [3/1]
3			91-154 518-05
4	B♦	4,5	91-150 694-24/001
5	B♦	4,5	91-059 968-05
6			91-264 154-25
7			91-701 179-15
8 - 10			91-262 804-91
8			91-262 805-25
9			91-262 806-05
10			91-000 621-15
11			11-108 174-15

-34/31

Zum Nähen besonders feiner
Stoffe.

For stitching delicate fabrics.

Para géneros m uy nos mediante.

适用于缝纫特薄材料。

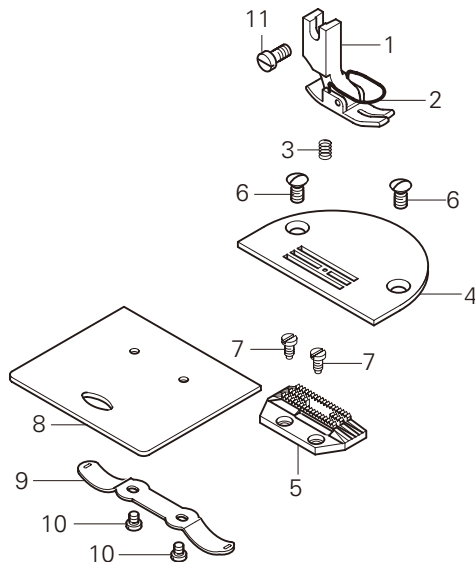

Pos.-Nr. Item No. 序号	Ausführung Model Typo 款式	Stichlänge Stitch length Largo de puntada 针距	Teile-Nr. Part No. 零件号
1 - 10	A♦	3,0	91-202 448-93/001
1 - 3	A♦	3,0	91-154 843-23/001
2			91-154 744-05 [3/1]
3			91-154 518-05
4	A♦	3,0	91-150 820-25
5	A♦	3,0	91-059 497-05
6			91-264 154-25
7			91-701 179-15
8 - 10			91-262 804-91
8			91-262 805-25
9			91-262 806-05
10			91-000 621-15
11			11-108 174-15

□ /♦ siehe Kapitel 2 Erläuterung der Schlüsselzeichen
see chapter 2 Explanation of key markings
véase el Cap. 2 Explicaciones de los signos clave
见第2章标记说明

▲ Weitere Unterklassen und Ausführungen auf Anfrage
Further Subclasses and versions on enquiry
Otras subclases y tipos, sobre demanda
更多的子机型和款式请咨询

22.02 Nähwerkzeuge ▲ Gauge parts Organos de costura 缝纫工具

MA 2083-948/26

-34/93

Zum Nähen besonders feiner Stoffe.

For stitching delicate fabrics. Para géneros muy nos mediante.

适用于缝纫特薄材料。

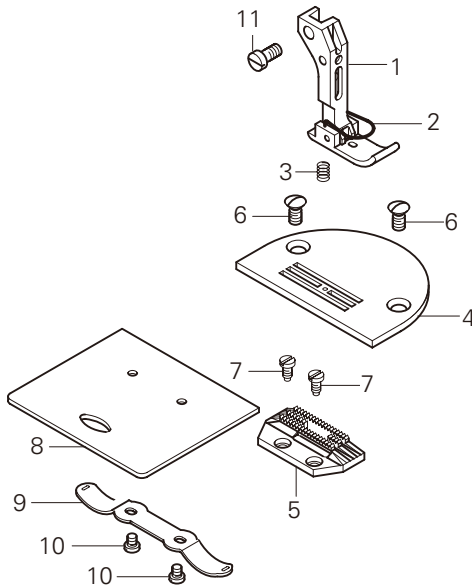

Pos.-Nr. Item No. 序号	Ausführung Model Typo 款式	Stichlänge Stitch length Largo de puntada 针距	Teile-Nr. Part No. 零件号
1 - 10	A♦	3,0	91-202 449-93/001
1 - 3	A♦	3,0	91-154 834-23/001
2			91-054 894-05 3/1
3			91-154 518-05
4	A♦	3,0	91-150 820-25
5	A♦	3,0	91-059 497-05
6			91-264 154-25
7			91-701 179-15
8 - 10			91-262 804-91
8			91-262 805-25
9			91-262 806-05
10			91-000 621-15
11			11-108 174-15

22.02 Nähwerkzeuge ▲ Gauge parts Organos de costura 缝纫工具

MA 2083
MA 2083-D

-731/01-8/31

Arbeitsgang
Operation
Opéracion
工序

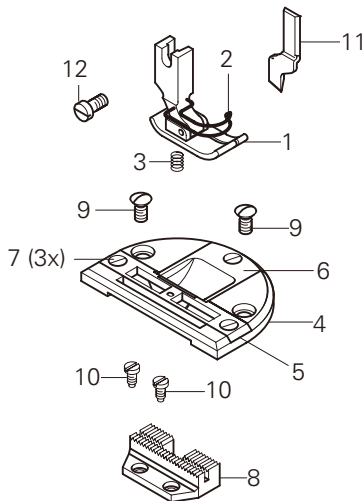
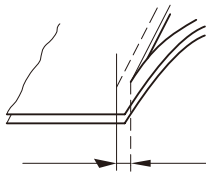

Pos.-Nr. Item No. 序号	Ausführung Model Typo 款式	Stichlänge Stitch length Largo de puntada 针距	Schneidabstand Trimming margin Margen de corte 切边距离	Teile-Nr. Part No. 零件号
1 - 11	B♦	4,5	5,0	91-202 364-93/001
	B♦	4,5	7,0	91-202 364-93/002
1 - 3	B♦	4,5	4,0	91-154 794-03/005
	B♦	4,5	4,5	91-154 794-03/006
	B♦	4,5	5,0	91-154 794-03/001
	B♦	4,5	6,0	91-154 794-03/007
	B♦	4,5	7,0	91-154 794-03/008
2				91-154 797-05 3/1
3				91-154 518-05
4 - 7	B♦	4,5	5,0	91-150 680-93/001
	B♦	4,5	7,0	91-150 680-93/002
4				91-150 677-05
5	B♦	4,5	4,0	91-048 705-03/012
	B♦	4,5	4,5	91-048 705-03/013
	B♦	4,5	5,0	91-048 705-03/014
	B♦	4,5	6,0	91-048 705-03/016
	B♦	4,5	7,0	91-048 705-03/025
6	B♦	4,5	4,0	91-048 703-04/004
	B♦	4,5	4,5	91-048 703-04/005
	B♦	4,5	5,0	91-048 703-04/006
	B♦	4,5	6,0	91-048 703-04/008
	B♦	4,5	7,0	91-048 703-04/010
7				91-000 730-25
8	B♦	4,5	4,0	91-047 464-04/009
	B♦	4,5	4,5	91-047 464-04/010
	B♦	4,5	5,0	91-047 464-04/011
	B♦	4,5	6,0	91-047 464-04/012
	B♦	4,5	7,0	91-047 464-04/013
9				91-264 154-25
10				91-701 179-15
11				91-169 395-04/002
12				11-108 174-15

Steuerungspaket ASD58-55
Control package ASD58-55
Paquete de control ASD58-55
控制组件 ASD-55

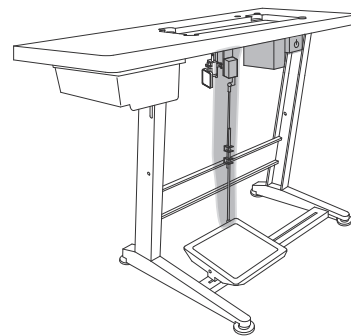

Bausatz 96-203 626-91 (besteht aus:)
Kit 96-203 626-91 (consisting of:)
Juego de piezas 96-203 626-91 (compuesto de:)
组件 96-203 626-91 (由下列部分组成)

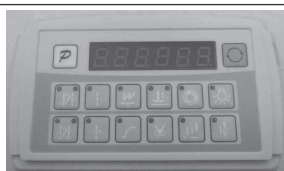
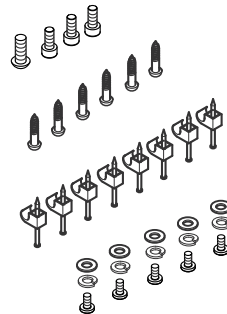
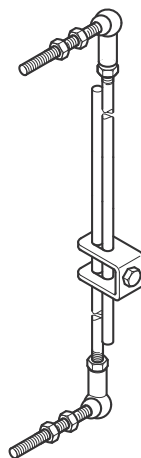
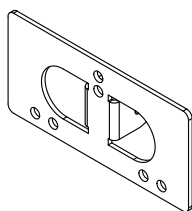
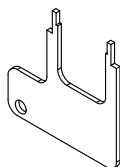
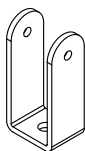
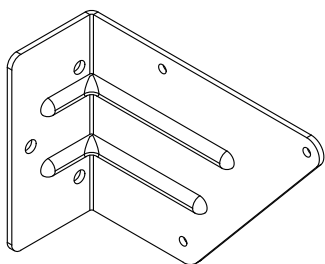
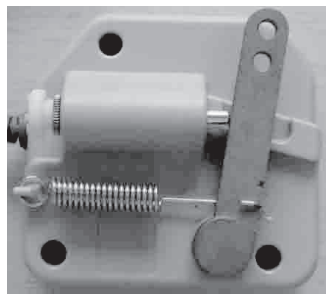
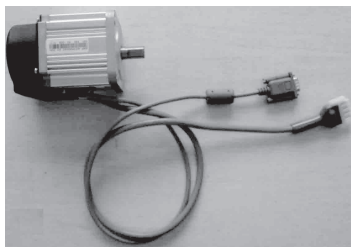



Mauser Spezial

Pfaff Industrial (Taicang) Co., Ltd.
A20 Foreign Industrial Park
No. 105 East Shanghai Road
215400 Taicang, Jiangsu, PRC

T: +86 (0)512 5328 3258
F: +86 (0)512 5328 3242
www.mauser-spezial.com
info@mauser-spezial.com

German Headquarter

Tribonia Intl. GmbH
Taunusstraße 5
65183 Wiesbaden
Germany